

PRACTICE FINAL EXAM

Choose the one best answer for each question; circle that answer on this test. This is a closed book and closed note exam. Copies of previous exams are not allowed.

APPENDIX

Building Heat Transfer:

k, conductivity (BTU-in/ hr ft²°F)

C, Conductance (BTU/ hr ft²°F)

$$\dot{Q}_{total} \text{ (BTU/hr)} = \dot{Q}_{conduction} + \dot{Q}_{infiltration} + \dot{Q}_{perimeter}$$

$$\dot{Q}_{infiltration} = (VHC \times Vol \times ACH) \times \Delta T$$

$$\dot{Q}_{total} = UA_{ref} \times \Delta T$$

$$UA_{ref} = (U \times A)_{envelope} + (VHC \times Vol \times ACH)_{air} + (K \times P)$$

$$C = 1/R$$

r, resistivity (hr ft²°F/BTU -in)

R, Resistance (hr ft²°F/BTU)

$$U_{value} = 1/R_{total}$$

$$T_{balance \ point} = T_{therm.} - (Q_{free}/U \times A_{ref})$$

ΔT = temperature difference (inside - outside)

Q = BTU (energy); \dot{Q} = BTU/hr

Passive Heating & Cooling:

Thermal Mass = SH x density x volume
 = SH x mass
 = VHC x volume

$$Q = TM \times dt$$

SH = Specific Heat (BTU/lb °F)
 VHC = Volumetric Heat Capacity (BTU/ft³ °F)
 TM = Thermal Mass (BTU/°F)

dt = change in temperature (before and after)

Material	Specific Heat (BTU/lb - °F)	Density (lb/ft ³)	VHC (BTU/ft ³ - °F)
Water	1.0	62.0	62.0
Air	0.24	0.075	0.018
Concrete	0.20	120.0	24.0
Steel	0.12	515.0	61.8

Water weighs approximately 8 lbs/gallon
 ("a pint's a pound the world around," 2 pints = 1 quart; 4 quarts = 1 gallon)

Lighting

$$E = (I / D^2) \cos \theta$$

L = Luminance (fL or foot-Lambert)

E = Illumination (fc or footcandle)

I = Luminous Intensity (candelas)

TRUE OR FALSE
2 points each

- T F 1. An un-shaded south facing window receives nearly the same solar gain as an un-shaded north facing window on a sunny June 21st day here in Seattle.
- T F 2. In Seattle, **direct gain solar heating** is likely to be an appropriate climate response strategy for **both** a 30 story high rise office tower *and* a detached single family residence.
- T F 3. The more internal heat gains a building has from people, lights and equipment, the **lower** its balance point temperature becomes (remember: the balance point temperature is an outside/environmental temperature).
- T F 4. *Prior* to the 20th century, “metabolism” or energy conversion was the dominant means of architectural adaptation to environmental conditions; for the past century, “location” and “form” have become the dominant means of adaptation to the environment.
- T F 5. “Buoyancy,” the effect that causes warmed air to move upward, is the driving force that causes cool moist air to be drawn inland resulting in summertime fog in San Francisco.
- T F 6. While the two may appear very similar when installed, a **photovoltaic panel** (PV) converts sunlight to electricity, while a **solar thermal panel** is designed to use sunlight to heat water, air, or another fluid.
- T F 7. Pound-for-pound, steel is a **better** source of thermal mass than water.
- T F 8. Standard clear glass is highly transparent to shortwave radiation (visible light) but is nearly opaque to longwave radiation (room IR or heat).
- T F 9. For cross ventilation of a room or building to be most effective, you should have outlets equal to or greater in size than the inlets.
- T F 10. An (interior) “light shelf”, a light colored horizontal panel located above head-height in a space with high windows, generally **increases** the illumination level in a space.
- T F 11. On June 21, at solar noon in Honolulu, Hawaii (Latitude = 21°) the sun is in the northern portion of the sky vault (altitude = 92.5°)
- T F 12. A clerestory window (vertical, high in a space) receives more daylight on a uniformly overcast day than a skylight (horizontal window) of the same size.
- T F 13. Low-E glass is transparent to short wave radiation (visible light) and reflective to long-wave radiation (room IR or heat).
- T F 14. In Seattle, direct beam sunlight will never enter a north-facing window.
- T F 15. A cubic foot of water has a higher heat capacity than a cubic foot of concrete.

MULTIPLE CHOICE

4 points each

Choose the one best answer for each question; circle that answer on this test.

16. A fixed horizontal shading device is generally *most* effective as a shading device for
- A. south-facing windows
 - B. west-facing windows
 - C. east-facing windows
 - D. north-facing windows
17. If the energy going **into** a building is **less than** the energy **leaving** the building, the building is no longer in thermal equilibrium and
- A. the building temperature rises. If the building contains lots of available thermal mass, it rises more *slowly* than if there is little thermal mass available.
 - B. the building temperature stays the same as long as there is plenty of thermal mass to soak up the energy.
 - C. the building temperature rises. If the building contains lots of available thermal mass, it rises more *quickly* than if there is little thermal mass available.
 - D. the building temperature will go down. If the building contains plenty of available thermal mass, the temperature inside will fall more slowly than if there is just a small amount of thermal mass available.
18. High performance glass can play an important role in reducing how much cooling a building requires. The diagram to the right shows the desired properties of high performance glass for an internal load dominated building, which

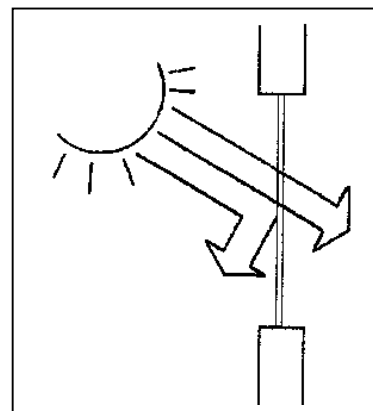

- A. transmits the entire solar spectrum.
- B. transmits the visible (“shortwave”) portion of the spectrum and reflects the solar infrared radiation.
- C. transmits the solar infrared portion of the spectrum and reflects the visible (“shortwave”) radiation.
- D. transmits the visible (“shortwave”) portion of the spectrum and absorbs the solar infrared.

19. What is the altitude angle (Alt) and azimuth angle (Az) of the sun at **9 am** on **September 21st** at this latitude (36° N)?

- A. Alt = 40° Az = 65° E
- B. Alt = 35° Az = 60° E
- C. Alt = 35° Az = 45° E
- D. Alt = 30° Az = 50° E

20. In Boulder, Colorado, **Latitude = 40° N**, what is the sun’s altitude at solar noon on **December 21st**?

- A. 50°
- B. 26.5°
- C. 78.5°
- D. 21.5°

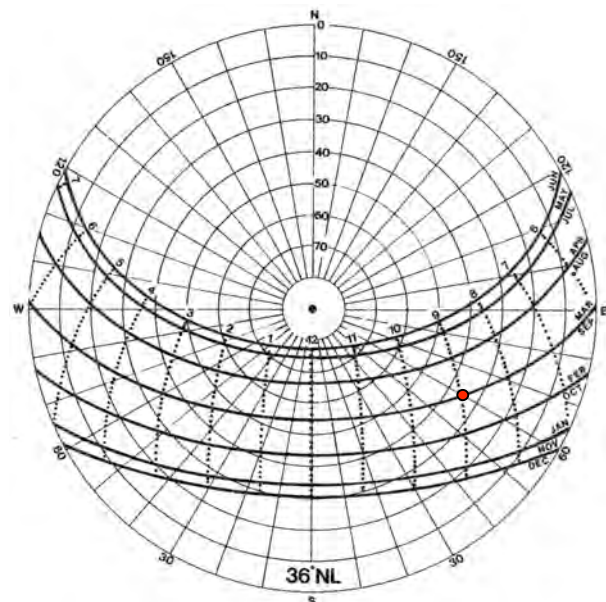

Questions 21 – 23: You’ve been asked by the owners of Real Goods to renovate a small building in Santa Maria, California for their new “Solar Showroom.” The building is relatively small (4000 SF), and you may consider it to be “envelope dominated.” The 2-hour temperature chart (below) is for Santa Maria, and the shaded areas indicate the “closed cooling” periods (75°F and above), and the “closed heating” periods (below 55°F) for this particular building.

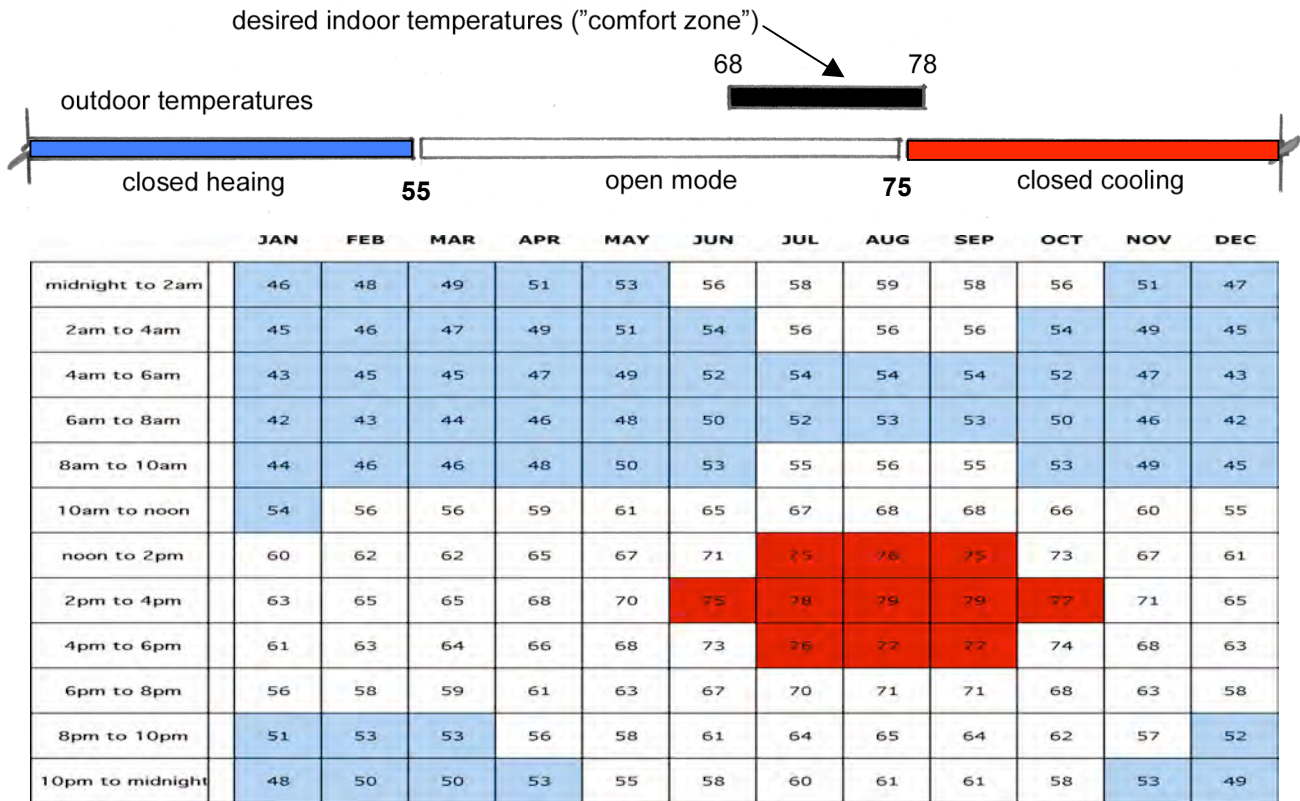

21. During the hours the showroom is typically open (10am to 6pm),
- direct gain passive solar heating is **rarely** necessary; however, solar energy collected during portions of this time, particularly November – May, can be stored for heating periods when the store is closed.
 - direct gain passive solar heating is appropriate **most of the time**; windows should allow direct gain solar penetration during all “open mode” hours.
 - direct gain passive solar heating is **necessary** to avoid having to turn on the furnace during the morning from February through May.
 - Shading devices should provide 0% to 50% shade from noon to 6pm from July through September.
22. Window shading devices for this building
- should begin providing at least *partial* shading when the outside temperature exceeds 55 °F.
 - should begin providing at least *partial* shading when the outside temperature exceeds 68 °F.
 - should provide full (100%) shading when the outside temperature exceeds 75 °F.
 - both A and C.
23. All of the following statements about this building are true EXCEPT:
- Architectural strategies could eliminate the need for both mechanical heating & cooling.
 - Night time “coolth” stored in the building’s thermal mass is an appropriate closed building cooling strategy from noon to 6 pm from July through September.
 - Cross ventilation is an appropriate cooling strategy from noon to 6pm from July through September.
 - Direct and indirect gain strategies (e.g. Trombe walls) that “charge” thermal mass with heat for use when the business is closed (early evening and early morning hours) are appropriate.

24. A client has asked you to design a fixed simple shading device for several south-facing windows on her office building in Bozeman, MT (46° N. Latitude). She wants the window to be fully (~100%) shaded during the “summer” half of the year (Mar. 21 – Sept. 21), but allow in some direct solar gain during the “winter” half (Sept. 21 – Mar. 21). What is the profile angle (Θ) that will best satisfy these requirements?

- A. 23.5°
- B. 31.5°
- C. 44°
- D. 50°

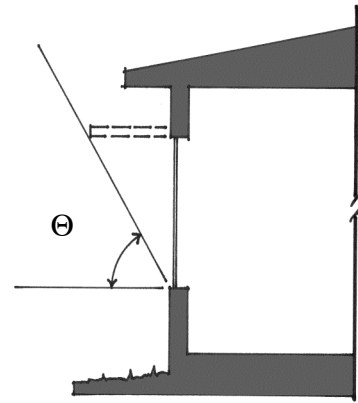

Refer to the following bio-psychrometric charts for questions 25 and 26.

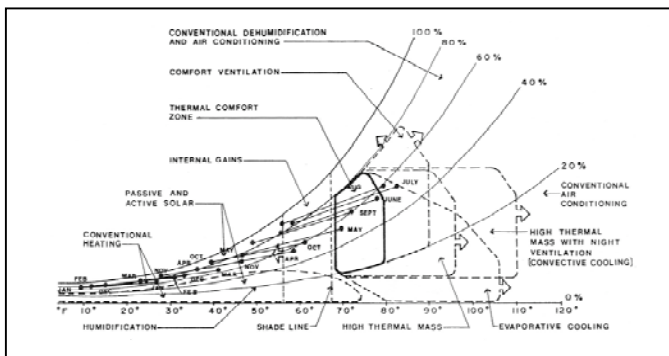

CLIMATE A

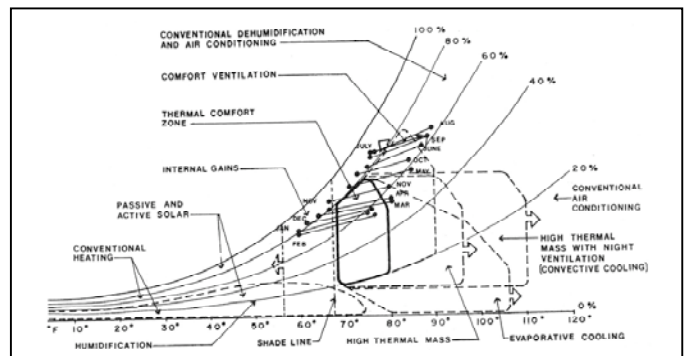

CLIMATE B

25. All of the following architectural design strategies are appropriate for a single family residence in BOTH climates to improve thermal comfort and reduce energy demands **EXCEPT**:
- A. Use evaporative cooling (“swamp cooler”) in the summer.
 - B. Use exterior window-shading devices to reduce solar gains in the summer.
 - C. Use daylighting to provide high-efficacy interior lighting, especially in the summer.
 - D. Provide operable windows so that the building can operate in open-mode for parts of the year.
26. All of the following statements are true **EXCEPT**:
- A. Night ventilation of thermal mass is an appropriate **summertime** strategy for a house in BOTH Climates A and B.
 - B. A large office building (internal load dominated) in Climate B is unlikely to require any heating.
 - C. Open-mode strategies for a house in Climate A would reduce the need for mechanical cooling.
 - D. “Keep the heat in and cold out in the winter” is one of the top “climate design priorities” for Climate A.
27. Which of the following options adds the most thermal mass (BTU/°F) to a small room measuring 10’ x 12’?
- A. A concrete slab measuring 10 ft. x 12 ft. x 3 inches (thick).
 - B. Two 55 gallon containers filled with water (water weighs ~8 lb/gal; neglect the thermal mass of the containers holding the water).
 - C. A steel partition that weighs 2000 lbs.
 - D. A “water wall” measuring 10 ft. x 4 ft. x 6 inches (neglect the thermal mass of the container holding the water).

Refer to the following wall section and table for questions 28 – 30.

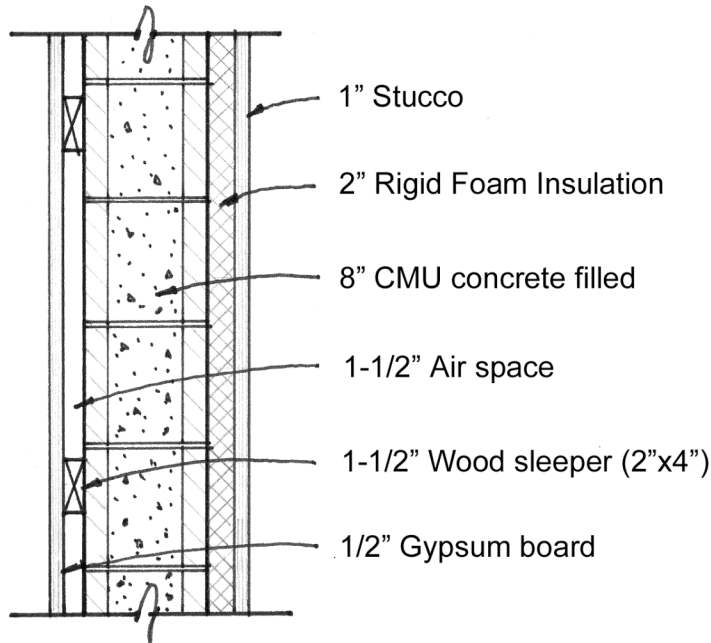

This is a (vertical) wall section of an insulated CMU (concrete masonry unit) wall, which has stucco on the outside and gypsum board on the inside attached to the wall using 2" x 4" wood "sleepers" @ 24" (horizontally) on center.

Path 1 (air space) = 85% wall area

Path 2 (wood sleepers) = 15% wall area

	k conductivity BTU - in hr ft ² °F	C Conductance BTU hr ft ² °F	R Resistance $\frac{\text{hr ft}^2 \text{ °F}}{\text{BTU}}$	R Path 1 (85%) $\frac{\text{hr ft}^2 \text{ °F}}{\text{BTU}}$	R Path 2 (15%) $\frac{\text{hr ft}^2 \text{ °F}}{\text{BTU}}$
INSIDE AIR FILM		1.47			
1/2" GYPSUM BOARD		2.22			
1-1/2" AIR SPACE			1.00		-
1-1/2" WOOD SLEEPER	1.00			-	
8" CMU, CONCRETE FILLED			1.10		
2" RIGID INSULATION	.20				
1" STUCCO		10.0			
OUTSIDE AIR FILM			.17		

28. What is the total R_{value} for **Path 1** through the **air space**, between the wood sleepers? (Note: answers may vary depending on decimal point round off – pick the closest value).
- 43.20
 - 28.50
 - 13.50
 - 5.00
29. Does this overall wall section (not counting doors and windows) comply with Title 24's mandatory minimum R-value requirements for wall assemblies, which is: $R_{\text{value}} = 13$ (hr ft² °F/BTU)?
- Yes
 - No
 - Depends on the climate zone
 - Not enough information about the wall assembly to determine this.
30. Which of the following would be the most effective way to **lower** the UA value of this wall?
- Attach two additional inches of rigid (R-10) insulation to the exterior (before applying stucco).
 - Fill the airspace with *Icynene* insulation having an R_{value} **per inch** = 4 (hr ft² °F/BTU-in).
 - Remove the rigid insulation from this assembly.
 - Attach the gypsum board directly to the CMU wall.
31. The architect Bart Prince used 10 acrylic water tubes in his direct-gain solar home in Albuquerque, NM, both decoratively and as thermal mass. Each tube contains approximately 50 gallons of water. If the water temperature in each tube goes up by 10°F on a typically sunny winter day, how much of the day's thermal energy has been stored in the thermal mass of the water?
NOTE: A gallon of water weighs approximately 8 pounds.
- 40,000 BTU
 - 80,000 BTU
 - 120,000 BTU
 - 160,000 BTU
32. All of the following statements about daylighting are true EXCEPT:
- Daylight is generally the most efficient way to illuminate an interior in terms of lumens of light per unit of heat (lumens/watt)
 - Under **uniformly overcast** skies, a window placed horizontally in a ceiling (skylight) experiences approximately 3 times the brightness of the same window placed vertically in a wall.
 - The depth of the "daylit" portion of a room is approximately 2.5 times the height of the window head above the workplane (~30" above the floor).
 - Surfaces outside a window have very little effect on the quality or quantity of daylight in a space.
33. For a room with windows having a head-height of 102" (8' – 6"), how far into the room does the "daylit" zone extend (the workplane is at 30" above the floor)?
- 10 feet
 - 12 feet
 - 15 feet
 - 20 feet

refer to the following tables to answer questions 34 and 35:

TABLE F.1 Design Guidelines for Passive Solar Glazing Area

Location	Area of Solar Glazing ^a as Ratio of Floor Area		Approximate SSF Values			
			Standard Performance ^b		Superior Performance ^c	
	Low	High	Low	High	Low	High
Birmingham, Alabama	0.09	0.18	22	37	34	58
Mobile, Alabama	0.06	0.12	26	44	34	60
Montgomery, Alabama	0.07	0.15	24	41	34	59
Phoenix, Arizona	0.06	0.12	37	60	48	75
Prescott, Arizona	0.10	0.20	29	48	44	72
Tucson, Arizona	0.06	0.12	35	57	45	73
Winslow, Arizona	0.12	0.24	30	47	48	74

TABLE F.2 Design Guidelines for Passive Solar Thermal Mass

Expected Solar Savings Fraction (SSF), %	Thermal Storage by Weight/Collector Area				Recommended Effective ^a Thermal Storage Area Per Unit Area of Solar Collection Area	
	Water		Masonry		Water Surface Area ^b	Masonry Surface Area ^c
	lb/ft ²	kg/m ²	lb/ft ²	kg/m ²	Collector Surface Area	Collector Surface Area
10	6	29	30	147	0.1	0.7
20	12	59	60	293	0.2	1.5
30	18	88	90	440	0.3	2.2
40	24	117	120	586	0.4	2.9
50	30	147	150	733	0.5	3.7
60	36	176	180	879	0.6	4.4
70	42	205	210	1026	0.7	5.1
80	48	234	240	1172	0.8	5.9
90	54	264	270	1319	0.9	6.6

Source: Adapted from J. D. Balcomb et al. (1980). *Passive Solar Design Handbook*, Vol. 2 (Passive Solar Design Analysis), U.S. Department of Energy, Washington, DC.

^aEffective area is that area exposed at some point to direct sun during a clear winter day.

^bFor a water container 12 in. (300 mm) thick.

^cFor a 4-in. (100-mm)-thick brick, density 123 lb/ft³ (1970 kg/m³).

34. Allen Affeldt, the owner of the historic La Posada Hotel in **Winslow, Arizona**, wants to build an “ecovillage” of affordable housing on a site adjacent to the hotel. You’ve proceeded to design a climate responsive, **1000 square foot** housing prototype that is rectangular and elongated east-to-west. According to the rule-of-thumb, which of the following choices achieves a **maximum SSF**?
- A. Provide approximately 24 sq. ft. of south glass for a SSF of 47.
 - B. Provide approximately 240 sq. ft. of south glass, insulated at night (R-9) for a SSF of 74.
 - C. Provide approximately 288 sq. ft. of south glass, insulated at night (R-9) for a SSF of 74.
 - D. Provide approximately 1000 sq. ft. of south glass, insulated at night (R-9) for a SSF of 48.
35. *Approximately* how much thermal mass should you provide in order to achieve this Solar Savings Fraction?
- A. Approximately 120 sq. ft. of 4-in. masonry
 - B. Approximately 240 sq. ft. of 4-in. masonry
 - C. Approximately 1300 sq. ft. of 4-in. masonry
 - D. Approximately 1561 sq. ft. of 4-in. masonry
36. Before you can rely on the accuracy of the anticipated solar savings fraction predicted by the rule-of-thumb method for direct gain solar strategies, your building must:
- A. have a tight, well-insulated envelope.
 - B. have sufficient thermal mass inside.
 - C. have sufficient south glass (“collector area”) that is un-shaded during the heating season.
 - D. satisfy all of the above.

Refer to the following illustration for question 37

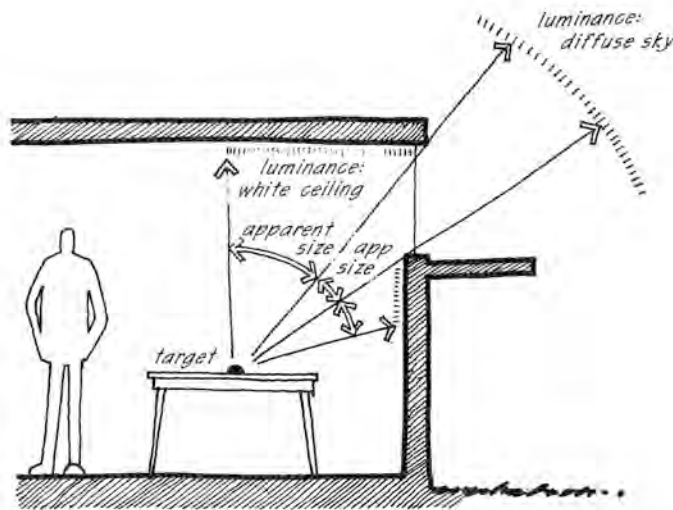

37. All of the following are true about the **LUMINANCE X APPARENT SIZE** conceptual model for designing with daylight EXCEPT:
- A. Illumination is a function of the areas of brightness that can be “seen” by the target.
 - B. The amount of light at the target is the result of exposure to all of the illuminated surfaces within view of that target.
 - C. This model provides a valid basis for designing with light when it emanates from a point source such as the sun.
 - D. The *apparent* size of luminous surfaces “seen” by the target is a function of size, tilt and distance of these bright surfaces.
38. For a **south-facing** window, the profile angle of the sun entering the room through the window stays the same all day long
- A. on December 21.
 - B. on March and September 21
 - C. on June 21.
 - D. on no day of the year.
39. A client has asked you for your advice on where to locate his solar collectors. He is installing **solar thermal panels** for heating his swimming pool (*May through August only*), and **photovoltaic panels** for charging batteries to power the lights on a Christmas display in his yard (*December only*). Which of the following choices provides the most solar energy for these times and uses?
- A. Solar Thermal (summer): on a flat rooftop (horizontal)
Photovoltaics (winter): south-facing wall (vertical)
 - B. Solar Thermal (summer): west-facing wall (vertical)
Photovoltaics (winter): on a flat rooftop (horizontal)
 - C. Solar Thermal (summer): south-facing wall (vertical)
Photovoltaics (winter): west-facing wall (vertical)
 - D. Solar Thermal (summer): on a flat rooftop (horizontal)
Photovoltaics (winter): west-facing wall (vertical)

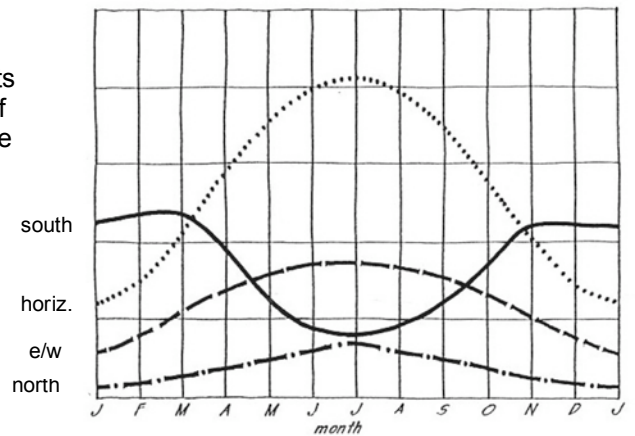

40. At the location of this site shading mask, approximately how many hours of direct sunlight is available on March/September 21 and on June 21?

- A. Mar/Sep 21 = 8.5 hrs
June 21 = 12 hrs
- B. Mar/Sep 21 = 6.5 hrs
June 21 = 8 hrs
- C. Mar/Sep 21 = 10.5 hrs
June 21 = 10 hrs
- D. Mar/Sep 21 = 10.5 hrs
June 21 = 12 hrs

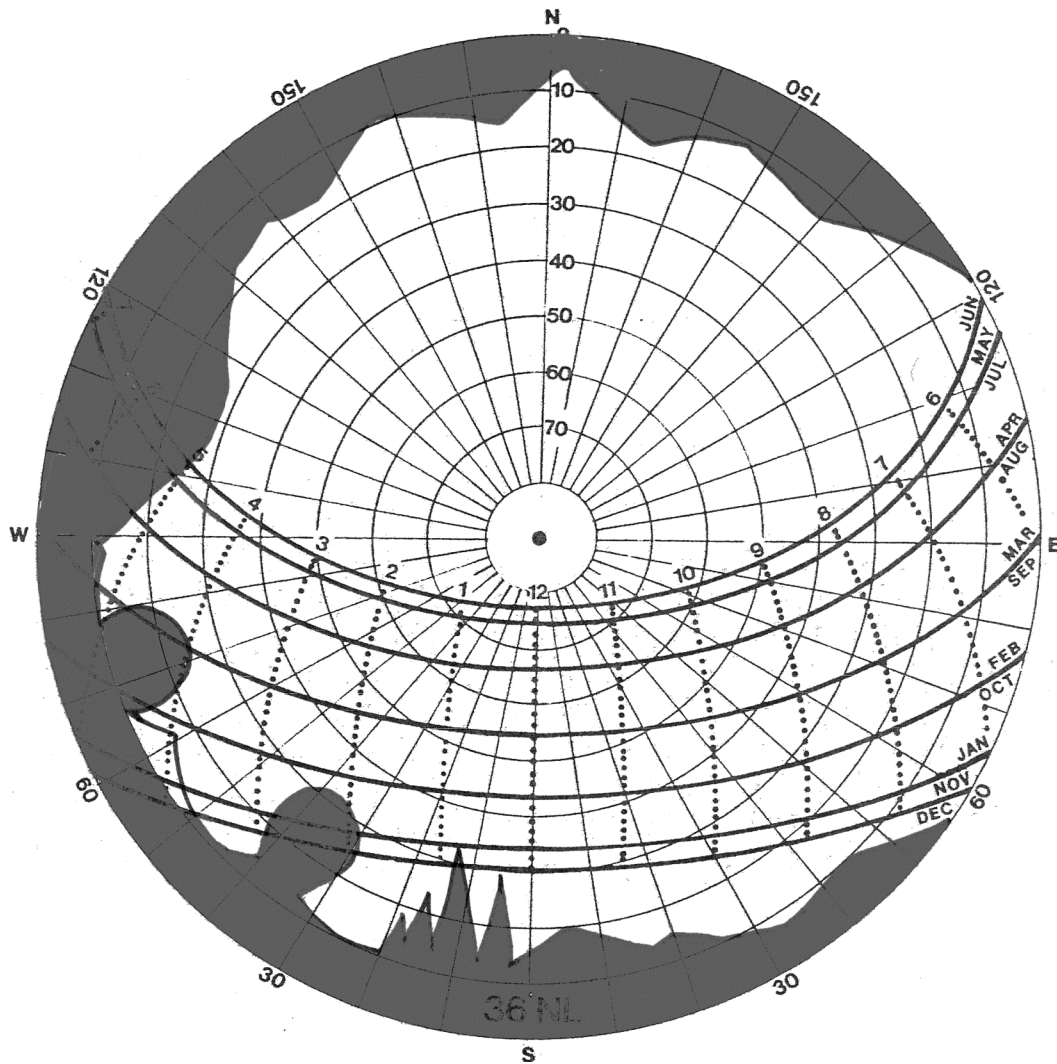

END OF EXAM