

# Personal Protective Equipment: non-Respiratory protection

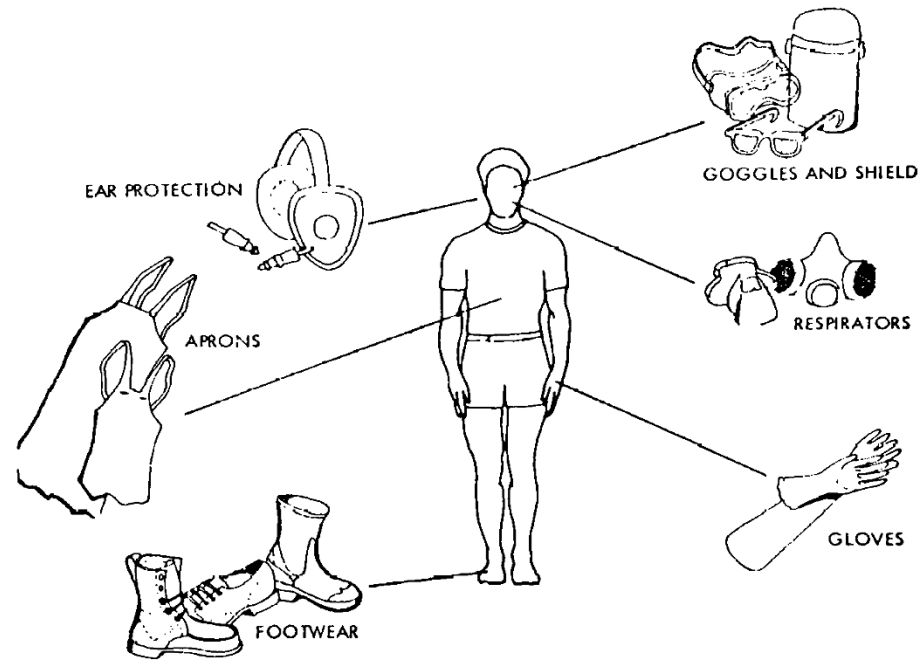

# Role of PPE

- **PPE is widely accepted and used**
  - **Employers often require PPE to enter a worksite**
  - **Employees often demand “safety gear”**
- **“Hierarchy of Controls” paradigm**
  - **Occupational hazards must first be controlled by engineering administrative means before relying on PPE**
  - **PPE is a “receiver” control**

# **OSHA' s 8-step PPE process**

- 1. Determine type of hazard(s) like to occur**
- 2. Determine adverse effects of unprotected exposures**
- 3. See if other control options can be used**
- 4. Determine performance characteristics needed**
- 5. Determine need for decontamination**
- 6. Determine ergonomic constraints presented**
- 7. Determine cost of various options**
- 8. Make the selection**

# **Employers are responsible for:**

- **Performing a "hazard assessment" of the workplace to identify and control physical and health hazards**
- **Identifying and providing appropriate PPE for employees**
- **Training employees in the use and care of the PPE**
- **Maintaining PPE -- replacing worn / damaged PPE**
- **Periodically reviewing, updating and evaluating the effectiveness of the PPE program**

# Employees should:

- Properly wear PPE,
- Attend training sessions on PPE,
- Care for, clean and maintain PPE, and
- Inform a supervisor of the need to repair or replace PPE



# Hazard assessment

•The hazard assessment should begin with a survey of the facility to develop a list of potential hazards in these categories:

- Impact
- Penetration
- Compression (roll-over)
- Chemical
- Heat/cold
- Harmful dust
- Light (optical) radiation
- Biologic agents
- Sources of electricity
- Sources of motion or impact
- High temperatures
- Chemicals used in the workplace
- Sources of harmful dusts
- Optical radiation: welding, brazing, cutting, high intensity lights, etc.
- Potential falling or dropping objects
- Sharp objects that could poke, cut stab or puncture.
- Biologic hazards such as blood or other potentially infected material

# OSHA PPE requirements

## 29 CFR subpart I

- 1910.133** Eye and face protection.
- 1910.134** Respiratory protection.
- 1910.135** Head protection.
- 1910.136** Foot protection.
- 1910.137** Electrical protective devices.
- 1910.138** Hand Protection.

## OSHA requires PPE to meet ANSI standards:

- **Eye and Face Protection: ANSI Z87.1-2003 (USA Standard for Occupational and Educational Eye and Face Protection).**
- **Head Protection: ANSI Z89.1-2003.**
- **Foot Protection: ANSI Z41.1-1991.**
- **Special standards for optical radiation**

There is no ANSI standard for gloves: OSHA recommends selection based on tasks and construction characteristics of the glove material.

# **Training Employees to Use PPE**

- **Employers are required to train each employee who use PPE**
- **Employees must be trained to know at least the following:**
- **When PPE is necessary.**
- **What PPE is necessary.**
- **How to properly put on, take off, adjust and wear the PPE.**
- **The limitations of the PPE.**
- **Proper care, maintenance, useful life and disposal of PPE.**
- **Employers must make sure employees demonstrate an understanding of the PPE training and the ability to properly wear and use PPE before they are allowed to perform work requiring the use of the PPE.**



# Specific PPE types

- **Eye and face protection:**
- **Head Protection**
- **Foot Protection**
- **Electrical Protective Devices**
- **Hand Protection**
- **Hearing Protection**
- **Protective Clothing**
- **(Chemical Protective Clothing and Respiratory Protection)**

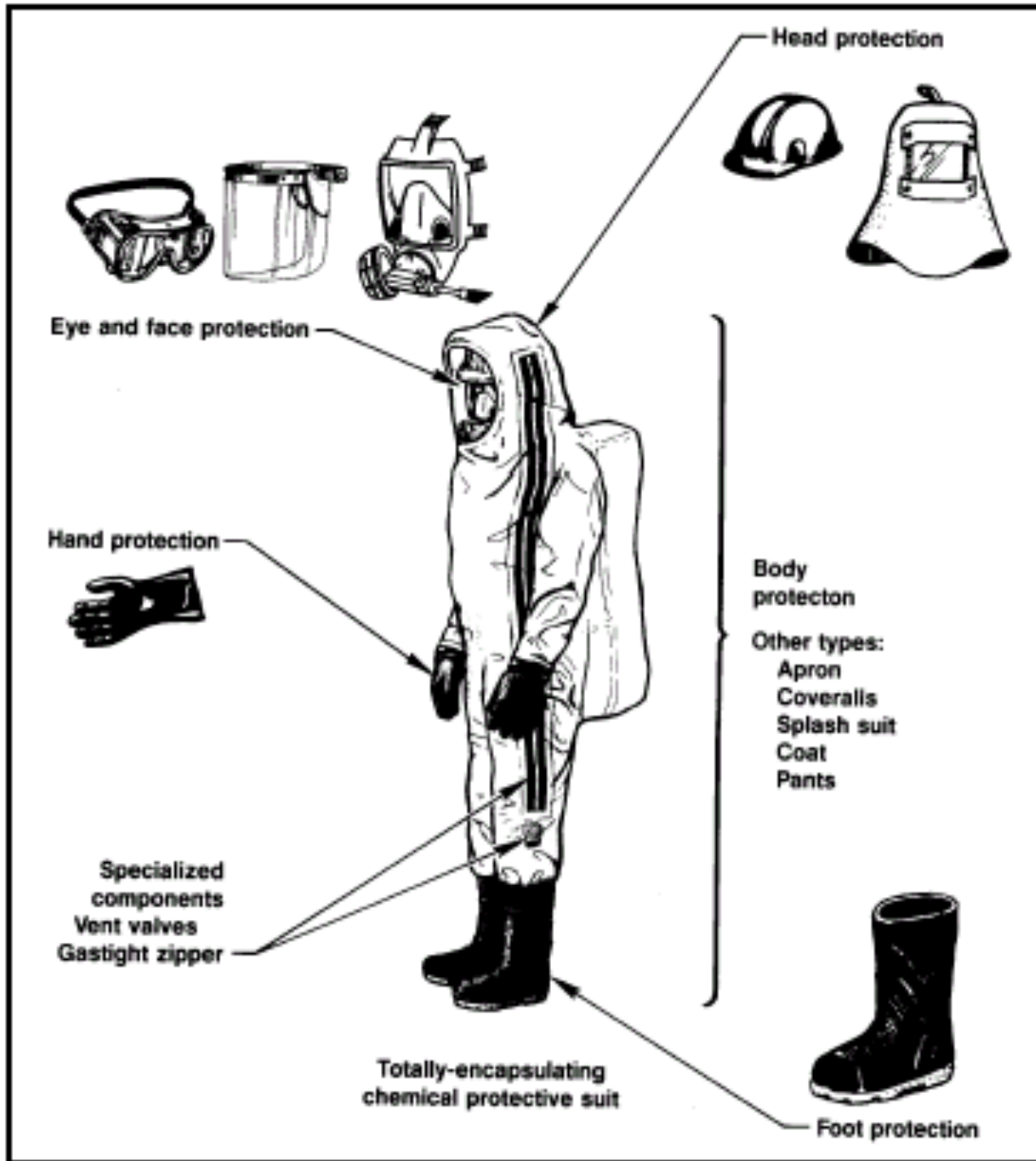

# Head Protection

- **Most head injuries occur to workers who were not wearing head protection**



# Head Protection

- Helmets or hard hats should:
- Resist penetration by objects
- Absorb the shock of a blow
- Water-resistant and slow burning
- Have clear instructions on adjustment and replacement of the suspension and headband
  - Shock-absorbing lining suspending shell ~1” away from the head: absorbs impact and gives ventilation
- Must meet ANSI Standard Z89.1-2003 (Protective Headgear for Industrial Workers)

# Types of Head Protection

- Hard hats are divided into three industrial classes:
- **Class A hard hats** provide impact and penetration resistance
  - along with limited voltage protection (up to 2,200 volts).
- **Class B hard hats** provide the highest level of protection against electrical hazards, with high-voltage shock and burn protection (up to 20,000 volts). They also provide protection from impact and penetration hazards by flying/falling objects.
- **Class C hard hats** provide lightweight comfort and impact protection but offer no protection from electrical hazards.
- **Bump hats** for use in areas with low head clearance
  - These are not designed to protect against falling or flying objects and are not ANSI approved.

# Head Protection: Care Considerations

- Remove and replace hard hats if they have:
- Perforation, cracking, or warping of the brim or shell;
- Indication of exposure to heat, chemicals or UV light (loss of surface gloss, chalking or flaking)
- Always replace a hard hat if it sustains an impact
- Suspension can be changed if excessive wear is noticed
- Never drill holes, paint or apply labels to headgear
- Do not store headgear in the rear window shelf of a car: sunlight and extreme heat can damage them

# Head Protection

- **ANSI Z89.1 (2003)**

- **Specifications: Adjustable headbands, sweat band, Shell supported by a suspension cradle and/or padding**
- **Testing**
  - » **Force transmission , Apex Penetration, Energy attenuation**
  - » **Off-center penetration (revised in 2003)**
  - » **Electrical**
- **Classifications of head protection**
  - » **Type I – impact on top only**
  - » **Type II – top or off-center impact**
  - » **Class G - limited voltages**
  - » **Class E - high voltages**
  - » **Class C - no voltage protection**

# Foot Protection

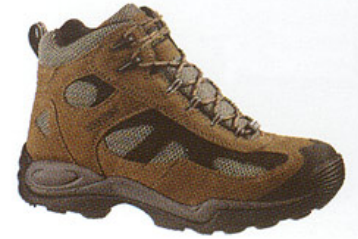

- **Toe and foot injuries account for 5% of all disabling workplace injuries. Workers not wearing safety shoes have 75% of all occupational foot injuries.**





# Foot and Leg Protection

- Situations where employees should wear foot / leg protection include:
  - Heavy objects such as barrels or tools might roll or fall in feet
  - Sharp objects such as nails or spikes that can pierce ordinary shoes
  - Exposure to molten metal that might splash on feet or legs
  - Working on or around hot, wet or slippery surfaces
  - Working when electrical hazards are present
- Safety footwear must meet ANSI minimum compression and impact performance standards in ANSI Z41-1999 (American National Standard for Personal Protection-Protective Footwear)
  - As of March 2005, ASTM F2413 standard supersedes the ANSI Z41 standard

# Foot and leg protection choices

- **Leggings** protect the lower legs and feet from heat hazards such as molten metal or welding sparks. Safety snaps allow leggings to be removed quickly.
- **Metatarsal guards** protect the instep area from impact and compression. Made of aluminum, steel, fiber or plastic, these guards may be strapped to the outside of shoes.
- **Toe guards** fit over the toes of regular shoes to protect the toes from impact and compression hazards. They may be made of steel, aluminum or plastic.
- **Combination foot and shin guards** protect the lower legs and feet, and may be used in combination with toe guards when greater protection is needed.
- **Safety shoes** have impact-resistant toes and heat-resistant soles that protect the feet against hot work surfaces common in roofing, paving and hot metal industries. The metal insoles in some safety shoes protect against puncture wounds.

# Special Purpose Shoes

- **Safety shoes** may also be designed to be electrically conductive to prevent the buildup of static electricity in areas with the potential for explosive atmospheres or nonconductive to protect workers from workplace electrical hazards.
- **Electrically conductive shoes** provide protection against the buildup of static electricity. Workers in explosive and hazardous locations such as explosives manufacturing facilities or grain elevators must wear conductive shoes to reduce the risk of static electricity buildup.
- **Electrical hazard, safety-toe shoes** are nonconductive and will prevent the wearers' feet from completing an electrical circuit to the ground. These shoes can protect against open circuits of up to 600 volts in dry conditions.
- **Foundry Shoes** insulate the feet from extreme heat and keep hot metal from lodging in shoe eyelets, tongues or other shoe parts.

# Protective Clothing

- **Protective clothing may be worn to shield against heat, chemicals, etc.**
- **Select clothing according to hazard and worksite conditions**
  - **Size**
    - » **ANSI/ISEA 101-199 standard**
  - **Chemical compatibility**
    - » **Addressed later in the course**
  - **Breathability**
    - » **Heat stress consideration**
- **Many OSHA standards apply**
  - **Carcinogens (asbestos, arsenic, etc.)**
  - **Abrasive blasting**
  - **Hazardous waste operations**
  - **Welding**
  - **Saw and paper mills**
  - **Fire fighting**
  - **Working over water (flotation)**
  - **Signaling (visibility)**

# Protective Clothing

- Need to protect workers from
  - Temperature extremes
  - Hot splashes from molten metals and other hot liquids
  - Potential impacts from tools, machinery and materials
  - Hazardous chemicals
- Variety of protective clothing available for specific hazards.
- Employers are required to ensure that their employees wear equipment for the parts of the body exposed to possible injury
- Clothing types
  - **Coveralls**
  - **Splash ("acid") suits**
  - **Totally-encapsulating chemical-protective suit ("moon suits")**
  - **Firefighters "turnout" gear**
  - **Protective sleeves**
  - **Aprons**
  - **Shoe covers, etc.**

# Protective clothing materials

- **Paper-like fiber** used for disposable suits provide protection against dust and splashes.
- **Treated wool and cotton** adapts well to changing temperatures, is comfortable, and fire-resistant and protects against dust, abrasions and rough and irritating surfaces.
- **Duck** is a closely woven cotton fabric that protects against cuts and bruises when handling heavy, sharp or rough materials.
- **Leather** used to protect against dry heat and flames.
- **Rubber, rubberized fabrics, neoprene and plastics:** When chemical or physical hazards are present, check with the clothing manufacturer to ensure that the material selected will provide protection against the specific hazard.

# **Chemical protective clothing analysis**

- **Job classification or task**
- **Process or task summary**
- **Potential or actual chemical hazards**
- **Physical properties of chemicals**
- **Potential or actual physical hazards**
- **Chemical contact periods**
- **Type of potential contact**
- **Body zones of potential contact**





### Recommended Sizing Chart for Limited-Use and Disposable Coveralls

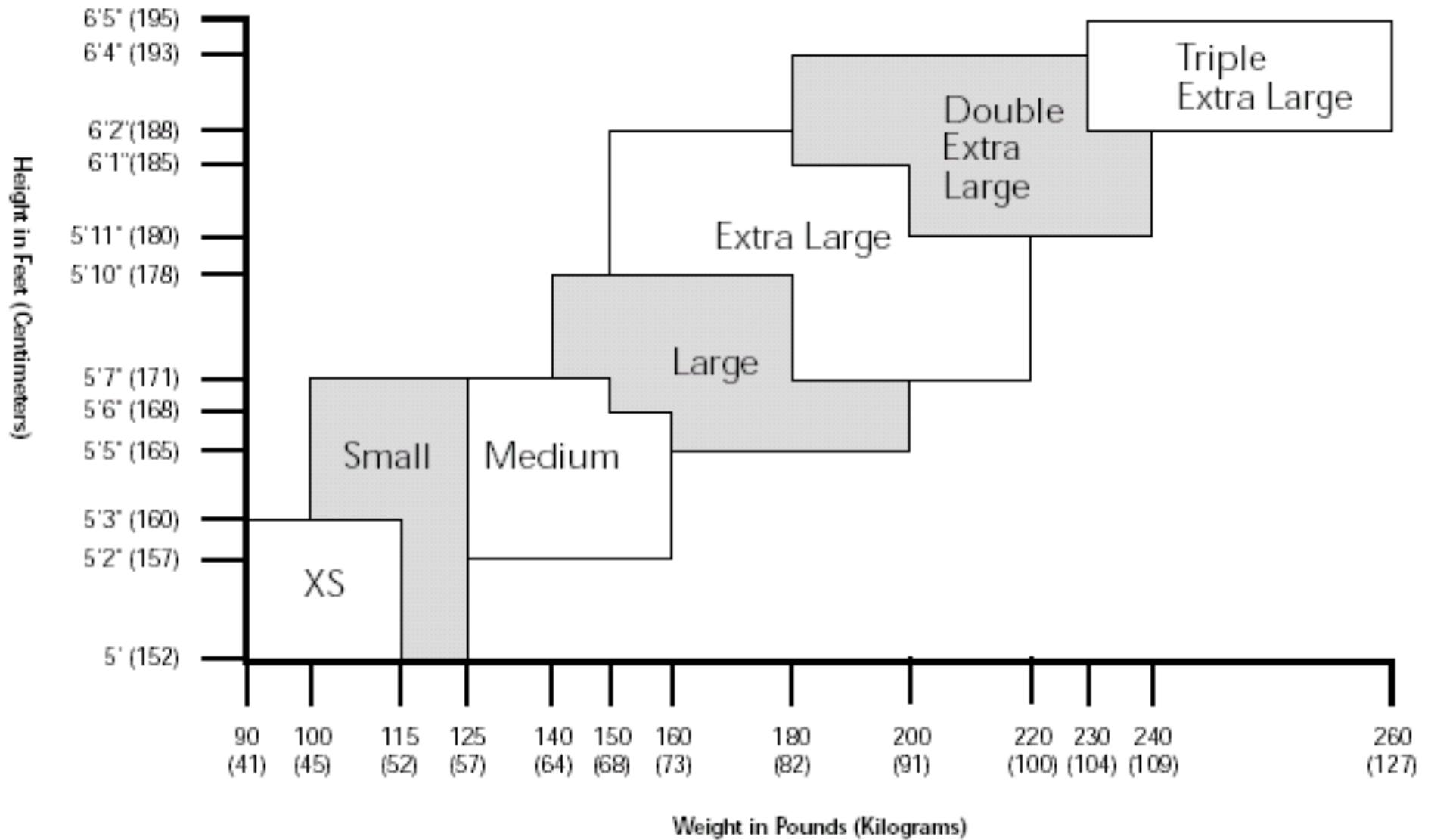

## Recommended Sizing Chart for Total Encapsulated Suits

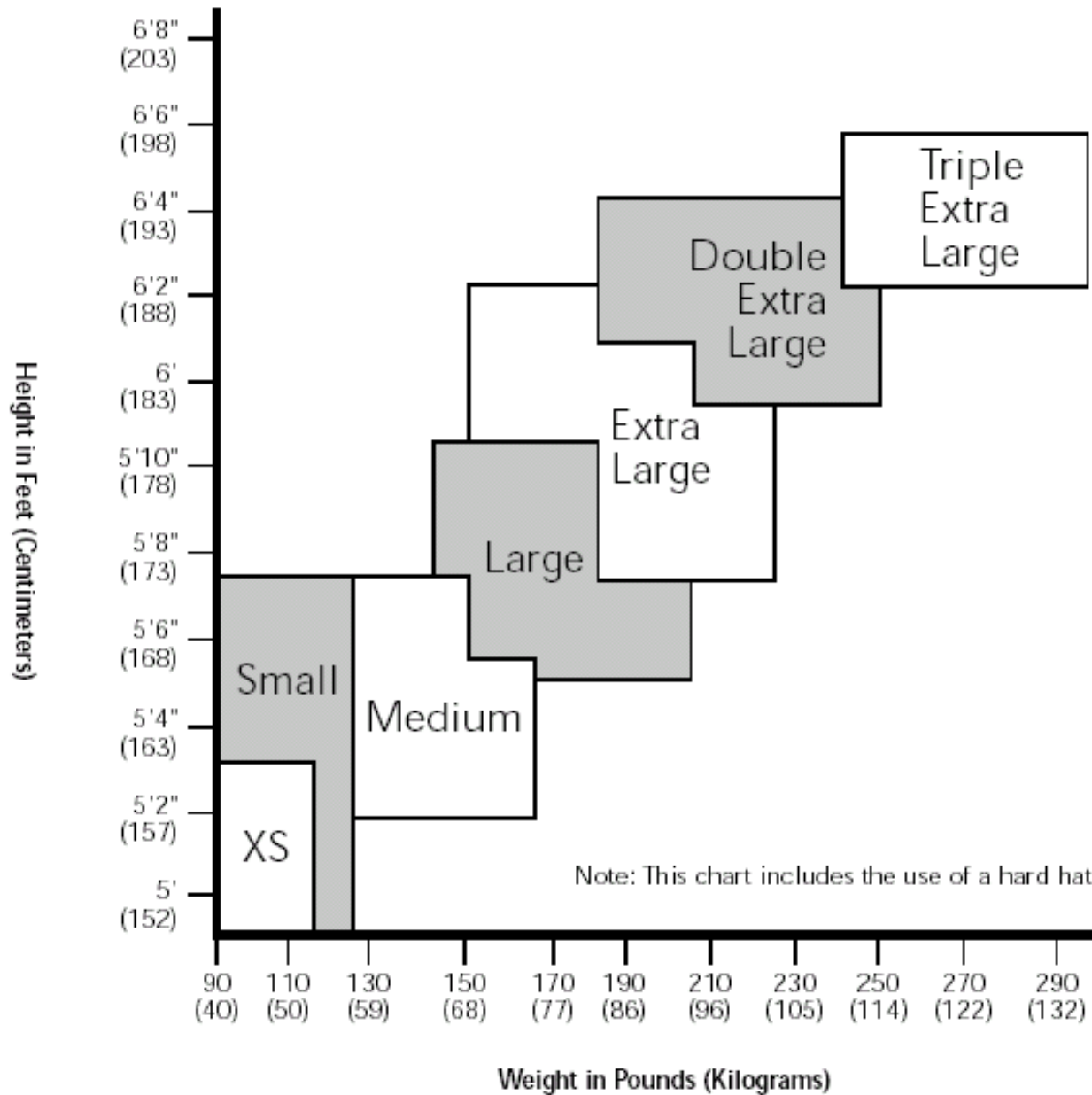

# Hand and Arm Protection

- **Hand and finger injuries account for 18% of all disabling injuries and about 25% of all industrial work place accidents**

# Types of Gloves

There are many types of protective gloves

**Leather gloves** protect your hands from rough surfaces.



**Special insulated gloves** can provide protection from hot objects.



**Cut-resistant gloves** prevent or reduce cuts from knives or sharp edges.



# Types of Gloves

**Anti-vibration gloves** reduce the effects of excessive vibration from hand-tools and machinery.



**Disposable gloves** protect against blood and germs in healthcare.



Various kinds of **chemical resistant gloves** prevent contact with chemicals.

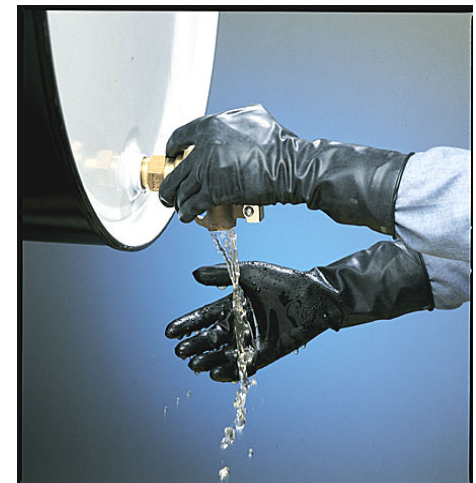

# Hand and Arm Protection

- **Some factors that influence selection of protective gloves:**
- **Type of chemicals handled.**
- **Nature of contact (total immersion, splash, etc.).**
- **Duration of contact.**
- **Area requiring protection (hand only, forearm, arm).**
- **Grip requirements (dry, wet, oily).**
- **Thermal protection.**
- **Size and comfort.**
- **Abrasion/resistance requirements.**
  - **Gloves materials fall into 4 groups**
  - **Leather, canvas or metal mesh**
  - **Fabric and coated fabric gloves**
  - **Chemical- and liquid-resistant gloves**
  - **Insulating rubber gloves**
    - (See 29 CFR 1910.137)

Dipped  
Sleeves



Molded  
Sleeves



# Electrically Insulated Gloves

## Certified Linesman's Gloves

These specialty gloves are used to handle live wires or energized electrical equipment.

They must be electrically tested every 6 months.

They can't be used if not tested within past 12 months.

Check for obvious signs of wear or holes before using.





# Leather, Canvas or Metal Mesh Gloves

- Sturdy gloves made from metal mesh, leather or canvas provide protection against cuts and burns. Leather or canvas gloves also protect against sustained heat.
- **Leather gloves** protect from sparks, moderate heat, blows, chips and rough objects.
- **Aluminized gloves** provide reflective and insulating protection against heat and require an insert made of synthetic materials to protect against heat and cold.
- **Aramid fiber gloves** protect against heat and cold, are cut- and abrasive-resistant and wear well.
- **Synthetic gloves** of various materials offer protection against heat and cold, are cut- and abrasive-resistant and may withstand some diluted acids. These materials do not stand up against alkalis and solvents.
- **Fabric and Coated Fabric Gloves** Fabric and coated fabric gloves are made of cotton or other fabric to provide varying degrees of protection.
- **Fabric gloves** protect against dirt, slivers, chafing and abrasions. Not sufficient for use with rough, sharp or heavy materials. (add plastic coating)
- **Coated fabric gloves** made from cotton flannel with napping on one side. Coating the un-napped side with plastic transforms these into general-purpose protection with slip-resistant qualities. Check with the manufacturer to determine effectiveness against specific chemicals and conditions.

# Chemical- and Liquid-Resistant Gloves

- Usually, the thicker the glove material, the greater the chemical resistance
- **Chemical-resistant glove materials:** rubber: natural, butyl, neoprene, nitrile and fluorocarbon (viton); plastic: polyvinyl chloride (PVC), polyvinyl alcohol and polyethylene. (may be blended or laminated)
- **Butyl gloves:** a synthetic rubber used for many chemicals, such as peroxide, rocket fuels, highly corrosive acids (nitric acid, sulfuric acid, hydrofluoric acid and red-fuming nitric acid), strong bases, alcohols, aldehydes, ketones, esters and nitro-compounds. Butyl gloves resist oxidation, ozone corrosion and abrasion, and remain flexible at low temperatures but don't perform well with aliphatic and aromatic hydrocarbons and halogenated solvents.
- **Natural (latex) rubber gloves** are comfortable and feature outstanding tensile strength, elasticity and temperature resistance. Protect workers' from most water solutions of acids, alkalis, salts and ketones. Latex gloves have caused allergic reactions in some individuals. (Hypoallergenic gloves available)
- **Neoprene gloves:** synthetic rubber offers good pliability, finger dexterity, high density and tear resistance. Protect against hydraulic fluids, gasoline, alcohols, organic acids and alkalis.
- **Nitrile gloves:** a copolymer that can stand up to heavy use and provides protection from chlorinated solvents such as trichloroethylene and perchloroethylene; also good for oils, greases, acids, caustics and alcohols but are generally not recommended for use with strong oxidizing agents, aromatic solvents, ketones and acetates.

# Care of Protective Gloves

- Gloves should be inspected before each use to ensure
- that they are not torn, punctured or made ineffective
  - Visual inspection
  - inspection by filling the gloves with water and rolling
- Discolored or stiff gloves may need replacement
- Reuse of chemical-resistant gloves should be evaluated carefully, taking into consideration the absorptive qualities of the gloves.
- A decision to reuse chemically-exposed gloves should take into consideration the toxicity of the chemicals involved and factors such as duration of exposure, storage and temperature.

# **Gloves and chemical protective clothing**

## **factors to consider**

### **Degradation**

- harmful change in one or more physical properties of a protective material when subjected to a chemical

### **• Penetration**

- the flow of chemicals through closures, zippers, seams, pinholes, etc.

### **• Permeation**

- movement of a chemical through a protective material

# Factors to consider (continued)

- **Permeation rate**

- the amount (mass) of chemical per unit time for an area of material once steady state has been achieved. Units are usually expressed as mg of chemical per square meter of material per minute (or second).
- Permeation tests are usually conducted for up to 8 hours. If no breakthrough, usually expressed as BT > 480 min.

- **Breakthrough time**

- time for a chemical to pass through a protective material

# 3 Steps for material testing

- ***Sorption*** of the chemical on the surface
  - ***Diffusion*** of the chemical through the material
  - ***Desorption*** of the chemical from the material's inside surface
- 

## Challenge and collection chambers used

- Collection chamber is swept with a gas or liquid to present the chemical to a sensitive analytical instrument.



**Figure 1.** A polyvinyl chloride coated nylon before and after exposure to dimethylformamide. (Photo courtesy of Intertek Testing Services, Cortland, New York.)

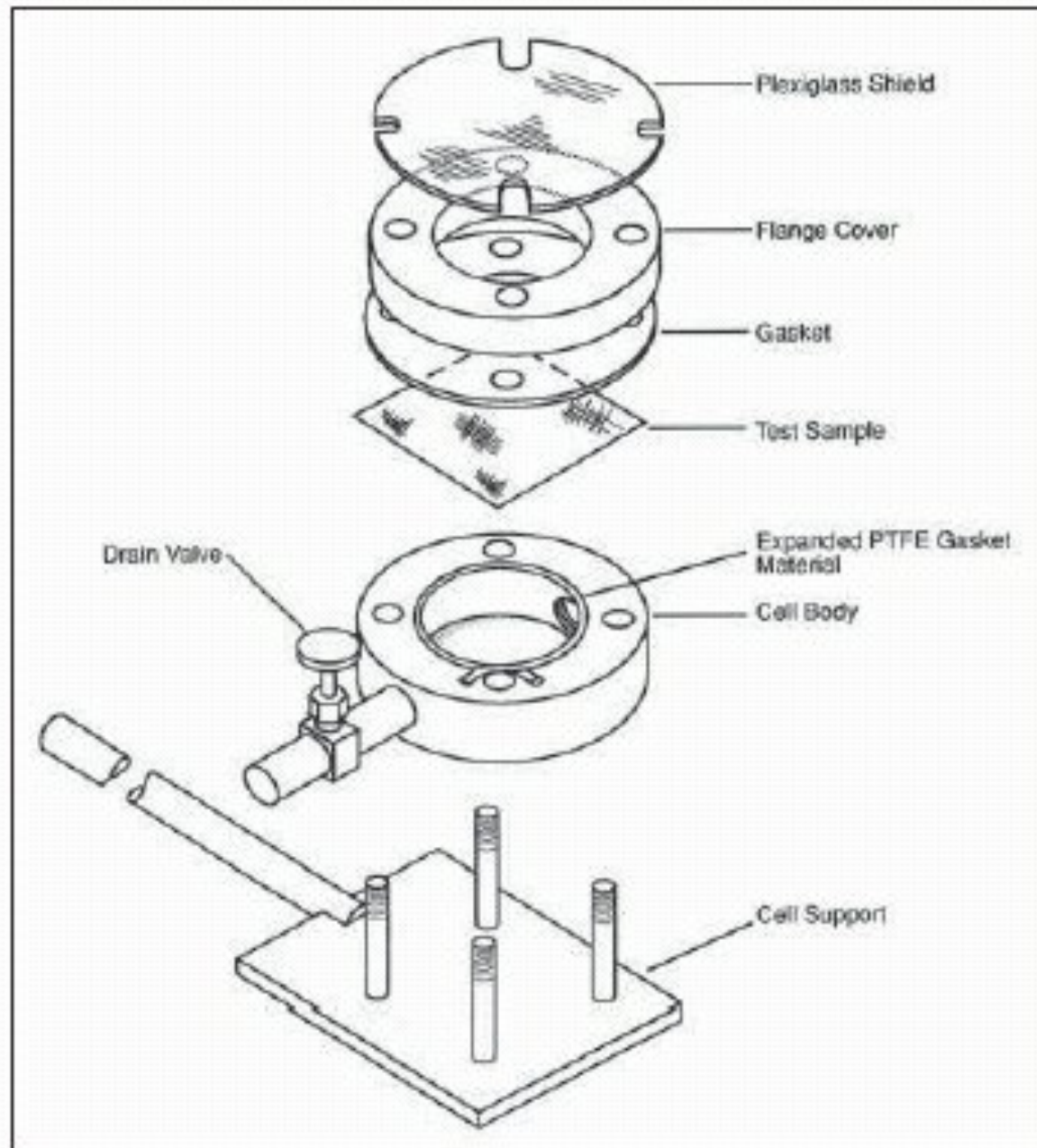

Figure 7. Exploded view of ASTM F 903 penetration test cell.



# Permeation

- **Measures of Permeation**
  - **Breakthrough Detection Time**
    - » **When the chemical is first detected**
    - » **Varies according to instrument sensitivity**
  - **Steady-state permeation rate**
    - » **Results usually reported as  $\mu\text{g}/\text{cm}^2/\text{min}$**
  - **Tested for continuous and/or intermittent exposure**
  - **Standard testing methods**
    - » **ASTM F 739-99a (continuous contact)**
    - » **ASTM F 1383-99a (intermittent contact)**

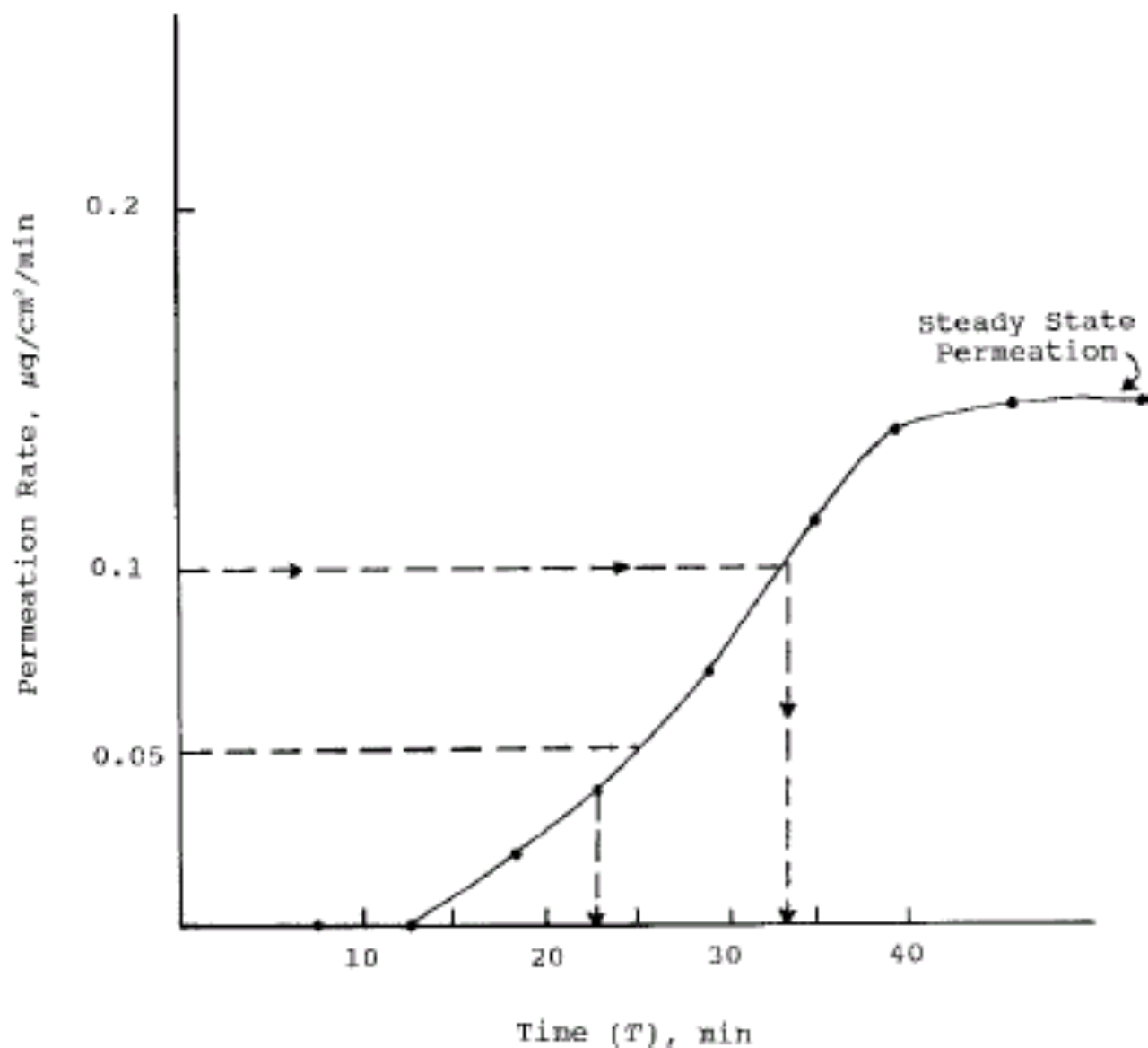

FIG. 5 The Breakthrough Detection Time for a method sensitivity of  $0.05 \mu\text{g}/\text{cm}^2/\text{min}$  is 23 minutes. The Normalized Breakthrough Detection Time is 33 minutes. The Steady State Permeation Rate is approximately  $0.15 \mu\text{g}/\text{cm}^2/\text{min}$ .

# Glove selection

- **Chemical toxicity**
- **Permeation parameters for chemical/glove**
- **Nature of exposure**
- **Physical factors associated with job**
  - cut resistance and tearing
  - manual dexterity and flexibility
  - temperature extremes
- **Cost**

# Eye and face protection



- **Eye injuries accounted for 5% of all disabling work injuries, estimated \$300 million annual cost.**
- **60% of workers with eye injuries were not wearing protective eyewear.**



# Eye and Face Protection

- Examples of potential eye or face injuries include:
  - Dust, dirt, metal or wood chips from chipping, grinding, sawing, hammering, etc.
  - Chemical splashes from corrosive substances, hot liquids or solvents
  - Objects swinging into the eye or face, such as tree limbs, chains, tools or ropes.
  - Radiant energy from welding, lasers or other radiant light
- Considerations for suitable protection:
  - Specific workplace hazards.
  - fit and comfort
  - Unrestricted vision and movement
  - Durable and cleanable
  - Unrestricted use of any other PPE
  - The eye and face protection must clearly identify the manufacturer
- Comply with ANSI Z87.1-2003
  - **Testing, marking, selection, care and use of protectors to prevent eye and face injuries**
  - **Revisions in 2003 introduced a two-tiered, performance based classification. Under the old standard, protectors bearing a “Z87” mark provided the highest level of impact protection. Under the new standard, protectors marked “Z87” only provide protection against Basic Impact forces and high Impact protectors have a “Z87+” or high impact mark.**

# Eye and face protection

- **29 CFR 1910.133, Eye and Face Protection**
  - Side protection when hazard from flying objects
  - Prescription eye protection or devices must fit over glasses for employees who wear glasses
  - Eye and face PPE shall be distinctly marked
  - Lenses for protection against radiant energy must have an appropriate shade number for the work being performed
  - Protective eye and face devices shall comply with ANSI Z87.1-2003, "American National Standard Practice for Occupational and Educational Eye and Face Protection,"

# How can eye injuries be prevented?

## Always wear effective eye protection.

To be effective, eye wear must appropriate for the hazard encountered and properly fitted.



## Better training and education.

BLS reported that most workers were hurt while doing their regular jobs.

Workers injured while not wearing protective eye wear most often said they believed it was not required by the situation.

Even though the vast majority of employers furnished eye protection at no cost to employees, about 40% of the workers received no information on where and what kind of eyewear should be used.

## Maintenance.

Eye protection devices must be properly maintained.

Scratched and dirty devices reduce vision, cause glare and may contribute to accidents.

# Eye and Face Protection Selection Chart

Source	Assessment of Hazard	Protection
<b>IMPACT</b> - chipping, grinding, machining, drilling, chiseling, riveting, sanding	Flying fragments, objects, large chips, particles, sand, dirt, etc.	Spectacles with side protection, goggles, face shields...for severe exposure, use face shields over primary eye protection
<b>HEAT</b> - furnace operations, pouring, casting, hot dipping, and welding	Hot sparks, splash from molten metals, high temperature exposure	Goggles or safety spectacles with special-purpose lenses and side shields. Many heat hazard require a face shield <i>in addition</i> to safety spectacles or goggles.
<b>CHEMICALS</b> – acid and chemicals handling degreasing, plating, and working with blood.	Splash, irritating mists	Goggles - shield eyes against liquid or chemical splash, irritating mists, vapors, and fumes.  Face Shields - secondary shield the entire face for chemical hazards.
<b>DUST</b> Woodworking, buffing, and general dusty conditions	Harmful Dust	Goggles-protect the eyes against airborne particles and dust
<b>OPTICAL RADIATION</b> welding, torch-cutting, brazing, soldering, and laser work	Radiant energy, glare, and intense light	Select filter lenses: begin with a shade too dark to see the welding zone. Then try lighter shades until you find the minimum protective shade to view of the welding zone



# Description and use of Eye/Face Protectors

## Glasses

Protective eyeglasses are made with

- safety frames
- tempered glass or plastic lenses
- temples and side shields



They provide eye protection from moderate impact and particles encountered in job tasks such as:

- carpentry
- woodworking
- grinding,
- scaling, etc.



Safety glasses are also available in prescription form for those persons who need corrective lenses.

# Description and use of Eye/Face Protectors

## Goggles

Vinyl framed goggles of soft pliable body design provide adequate eye protection from many hazards.

These goggles are available with

- clear or tinted lenses
- perforated, port vented, or non-vented frames.

Single lens goggles provide similar protection to spectacles and may be worn in combination with spectacles or corrective lenses to insure protection along with proper vision.

Welders goggles provide protection from sparking, scaling, or splashing metals and harmful light rays. Lenses are impact resistant and are available in graduated shades of filtration.

Chippers/Grinders goggles provide eye protection from flying particles. The dual protective eye cups house impact resistant clear lenses with individual cover.



# Description and use of Eye/Face Protectors

## Face Shields

These normally consist of an adjustable headgear and face shield of tinted or transparent acetate or polycarbonate materials, or wire screen.

Face shields are available in various sizes, tensile strength, impact/heat resistance and light ray filtering capacity.

Face shields will be used in operations when the entire face needs protection and should be worn to protect eyes and face against flying particles, metal sparks, and chemical/biological splash.



# Description and use of Eye/Face Protectors

## Welding Shields

These shield assemblies consist of vulcanized fiber or glass fiber body, a ratchet/button type adjustable headgear or cap attachment and a filter and cover plate holder.



These shields will be provided to protect workers' eyes and face from infrared or radiant light burns, flying sparks, metal spatter and slag chips encountered during welding, brazing, soldering, resistance welding, bare or shielded electric arc welding and oxyacetylene welding and cutting operations.



# Laser Operations

- Laser light radiation can be extremely dangerous to the unprotected eye and direct or reflected beams can cause permanent eye damage. Laser retinal burns can be painless, so it is essential that all personnel in or around laser operations wear appropriate eye protection.
- Laser safety goggles should protect for the specific wavelength of the laser and must be of sufficient optical density for the energy involved.
- Safety goggles intended for use with laser beams must be labeled with the laser wavelengths for which they are intended to be used, the optical density of those wavelengths and the visible light transmission.

# Selecting Laser Safety Glass

Intensity, CW maximum power density (watts/cm <sup>2</sup> )	Attenuation	
	Optical density (O.D.)	Attenuation factor
10 <sup>-2</sup>	5	10 <sup>5</sup>
10 <sup>-1</sup>	6	10 <sup>6</sup>
1.0	7	10 <sup>7</sup>
10.0	8	10 <sup>8</sup>

Source: 29 CFR 1926.102(b)(2).

# Hearing Protection

- **29 CFR 1910.95 requires hearing protection for employees exposed above 85 dB**
  - Hearing protectors are labeled with the NRR (noise reduction rating). Refer to 1910.95 for guidance.
- **Above 120 dBA conduction of noise to the inner ear starts to defeat plugs, muffs, etc.**
- **Types of protection devices:**
  - special helmets
  - ear muffs and cups
  - ear plugs (aural and supraaural)
  - fitting by medical people is advisable
  - supraaural “caps” held in place by bands - less effective
- **Combination muffs and plugs**
- **Above 1000 Hz - little difference between type**

# Hearing Protection

- **Types:**
  - **Ear plugs usually best for continuous exposure situations**
    - » **Formable (foam)**
    - » **Premolded**
    - » **Custom molded**
  - **Canal cap protectors are convenient when noise areas are frequently entered and exited**
    - » **Intra-aural**
    - » **Supra-aural**
  - **Ear muffs may be better for high frequencies, can be combined with ear plugs for extra protection**

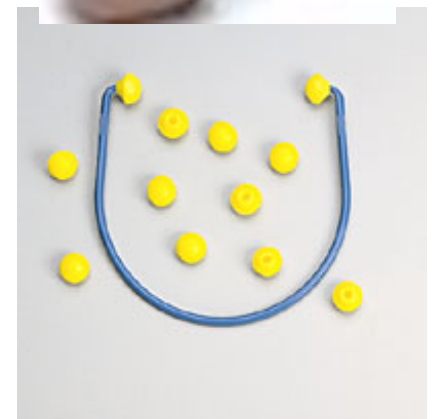



# Safety Eyewashes and Showers

- **OSHA standard CFR 1910.151, First Aid**
  - "Where the eyes or body of any person may be exposed to injurious corrosive materials, suitable facilities for quick drenching or flushing of the eyes and body shall be provided within the work area for immediate emergency use."
- **ANSI Z353.1, Emergency Eyewash and Shower Equipment**
  - Emergency showers and eyewash units must be readily accessible
    - » Accessible within 10 seconds
    - » Located as close to a hazard as possible (always within 100 ft.)
    - » Locations well lighted and identified with a highly visible sign

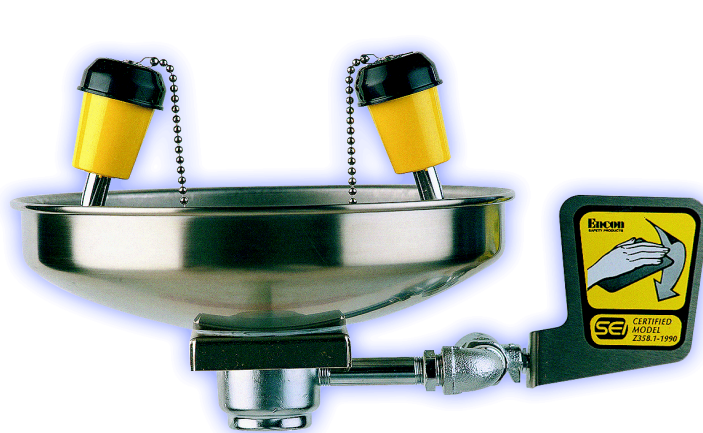

# Safety Eyewashes and Showers

- **ANSI Z353.1, (cont.)**
  - **Flowrate**
    - » Showers require at least 30 gpm
    - » Eyewash units must provide at least 0.4 gpm to both eyes for 15 minutes
    - » Valves remain activated until intentionally shut off
  - **Tested weekly**
  - **Hand operated drench hoses and eyewash bottles may be used to supplement but not replace eyewash and emergency shower equipment**



# The END

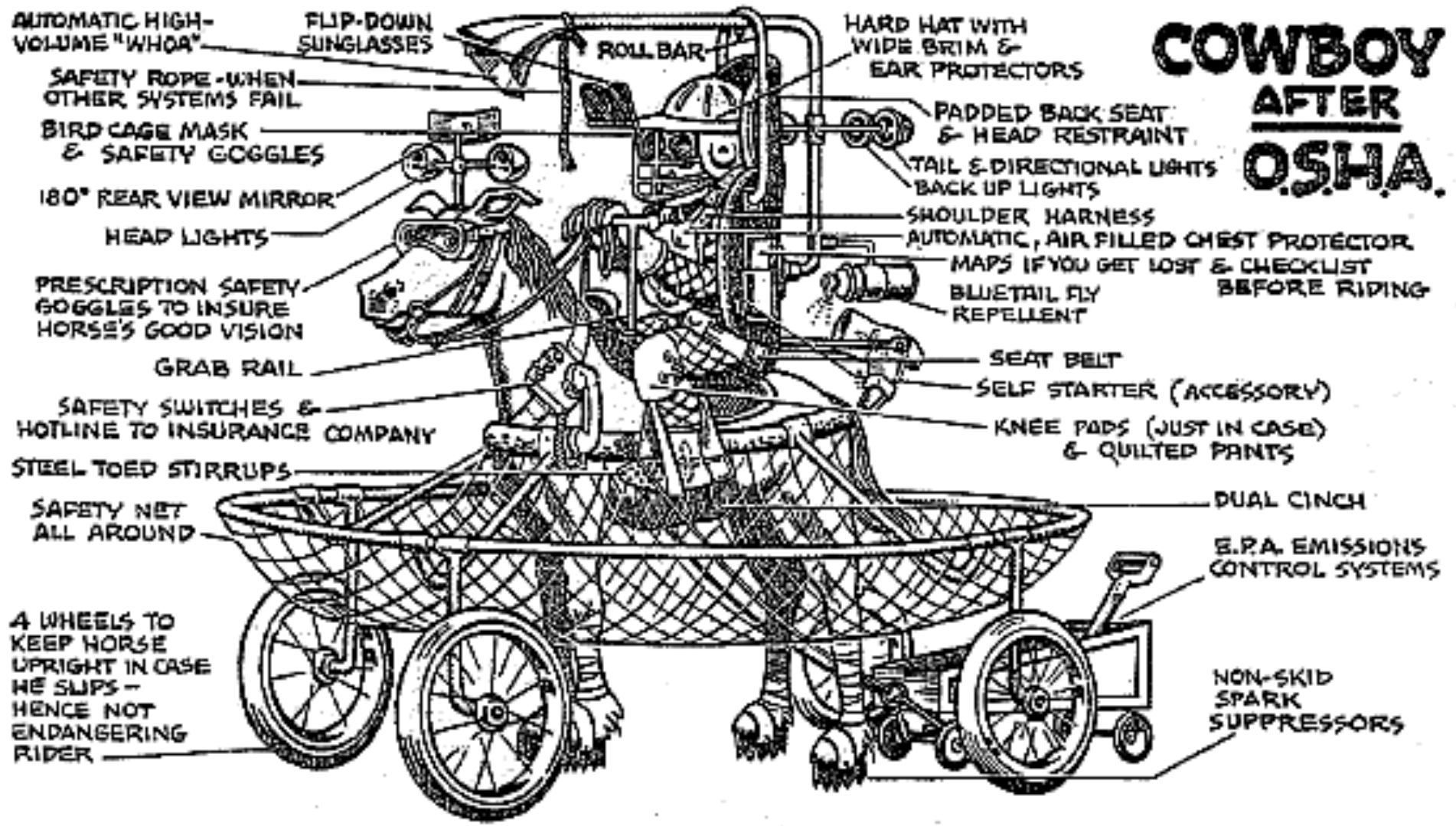

AUTOMATIC HIGH-VOLUME "WHOA"

FLIP-DOWN SUNGLASSES

ROLL BAR

HARD HAT WITH WIDE BRIM & EAR PROTECTORS

SAFETY ROPE - WHEN OTHER SYSTEMS FAIL

BIRD CAGE MASK & SAFETY GOGGLES

180° REAR VIEW MIRROR

HEAD LIGHTS

PRESCRIPTION SAFETY GOGGLES TO INSURE HORSE'S GOOD VISION

GRAB RAIL

SAFETY SWITCHES & HOTLINE TO INSURANCE COMPANY

STEEL TOED STIRRUPS

SAFETY NET ALL AROUND

4 WHEELS TO KEEP HORSE UPRIGHT IN CASE HE SLIPS - HENCE NOT ENDANGERING RIDER

## COWBOY AFTER OSHA.

PADDED BACK SEAT & HEAD RESTRAINT

TAIL & DIRECTIONAL LIGHTS  
BACK UP LIGHTS

SHOULDER HARNESS

AUTOMATIC, AIR FILLED CHEST PROTECTOR

MAPS IF YOU GET LOST & CHECKLIST BEFORE RIDING

BLUETAIL FLY REPELLENT

SEAT BELT

SELF STARTER (ACCESSORY)

KNEE PADS (JUST IN CASE) & QUILTED PANTS

DUAL CINCH

E.P.A. EMISSIONS CONTROL SYSTEMS

NON-SKID SPARK SUPPRESSORS