

Ling 566

Dec 6, 2007

Sign-Based Construction Grammar

Overview

Final exam posted

Overview of Differences

- Multiple Inheritance
- Signs
- Grammar rules form a hierarchy.
- Every tree node has its own phonology
- Many principles become constraints on grammar rules.
- The definition of well-formedness is simplified

Multiple Inheritance Hierarchies

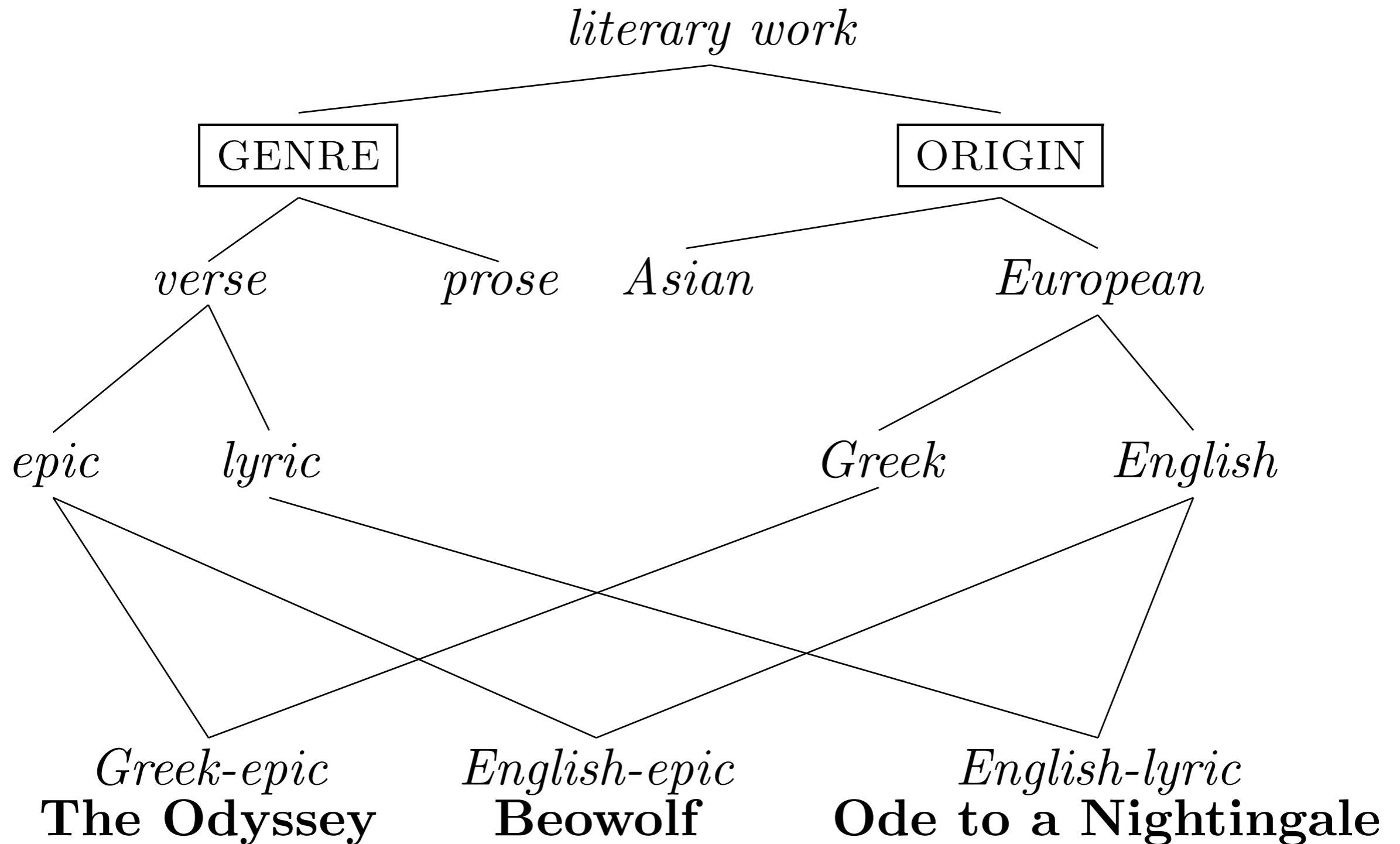

Lexeme Hierarchy

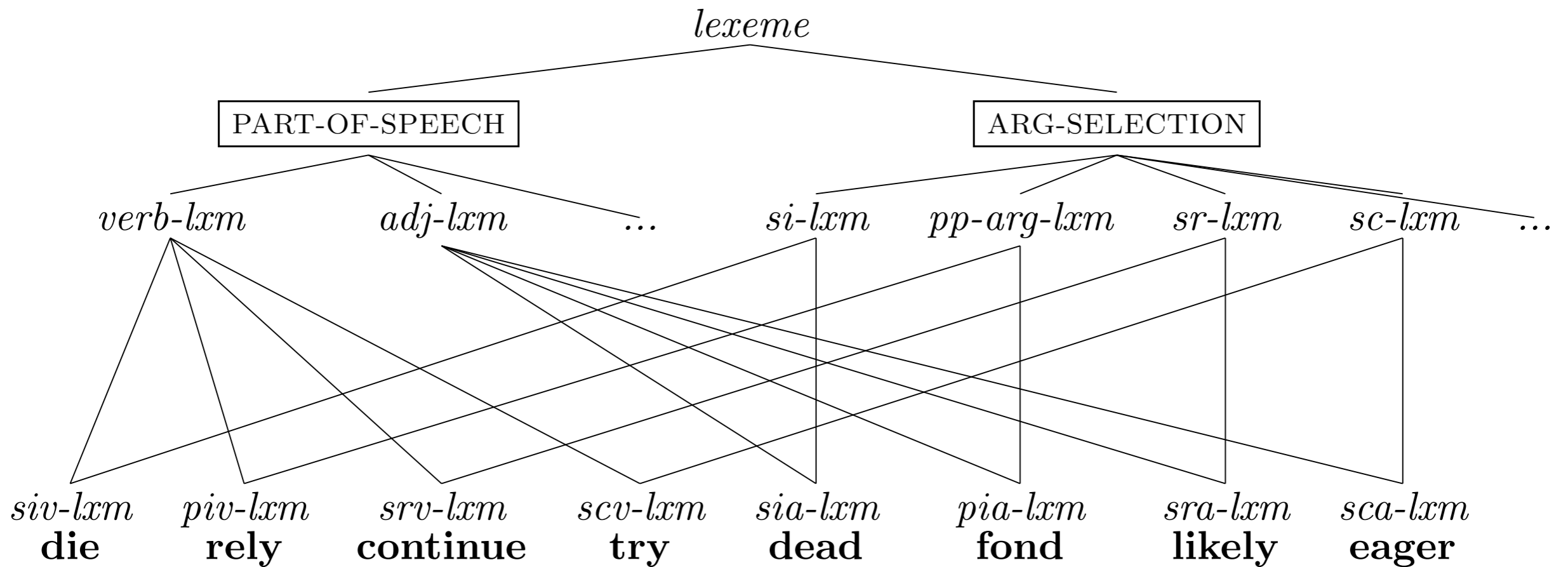

Lexeme Abbreviations

- *si-lxm* : *strict-intransitive-lexeme*
- *pp-arg-lxm* : *PP-argument-lexeme*
- *sr-lxm* : *subject-raising-lexeme*
- *sc-lxm* : *subject-control-lexeme*
- *siv-lxm* : *strict-intransitive-verb-lexeme*
- *piv-lxm* : *PP-intransitive-verb-lexeme*
- *srv-lxm* : *subject-raising-verb-lexeme*
- *scv-lxm* : *subject-control-verb-lexeme*
- *sia-lxm* : *strict-intransitive-adjective-lexeme*
- *pia-lxm* : *PP-intransitive-adjective-lexeme*
- *sra-lxm* : *subject-raising-adjective-lexeme*
- *sca-lxm* : *subject-control-adjective-lexeme*

Lexeme Constraints

- $si-lxm : \left[\text{ARG-ST} \langle X \rangle \right]$
- $pp-arg-lxm : \left[\text{ARG-ST} \langle X, PP \rangle \right]$
- $sr-lxm : \left[\text{ARG-ST} \left\langle \boxed{1}, \left[\text{SPR} \langle \boxed{1} \rangle \right] \right\rangle \right]$
- $sc-lxm : \left[\text{ARG-ST} \left\langle \text{NP}_i, \left[\text{SPR} \langle \text{NP}_i \rangle \right] \right\rangle \right]$

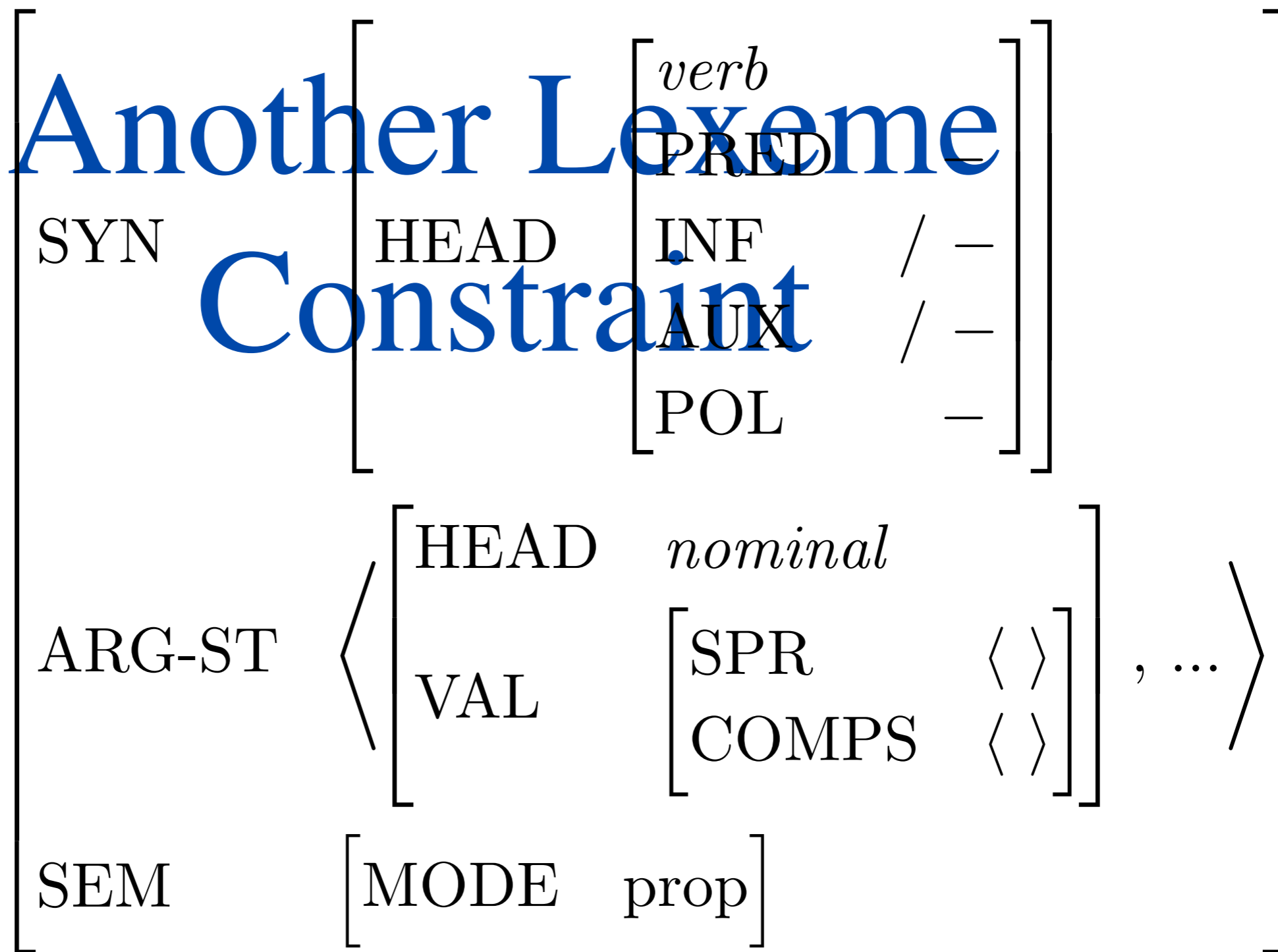

verb-lexm :

And Another

adj-lxm :

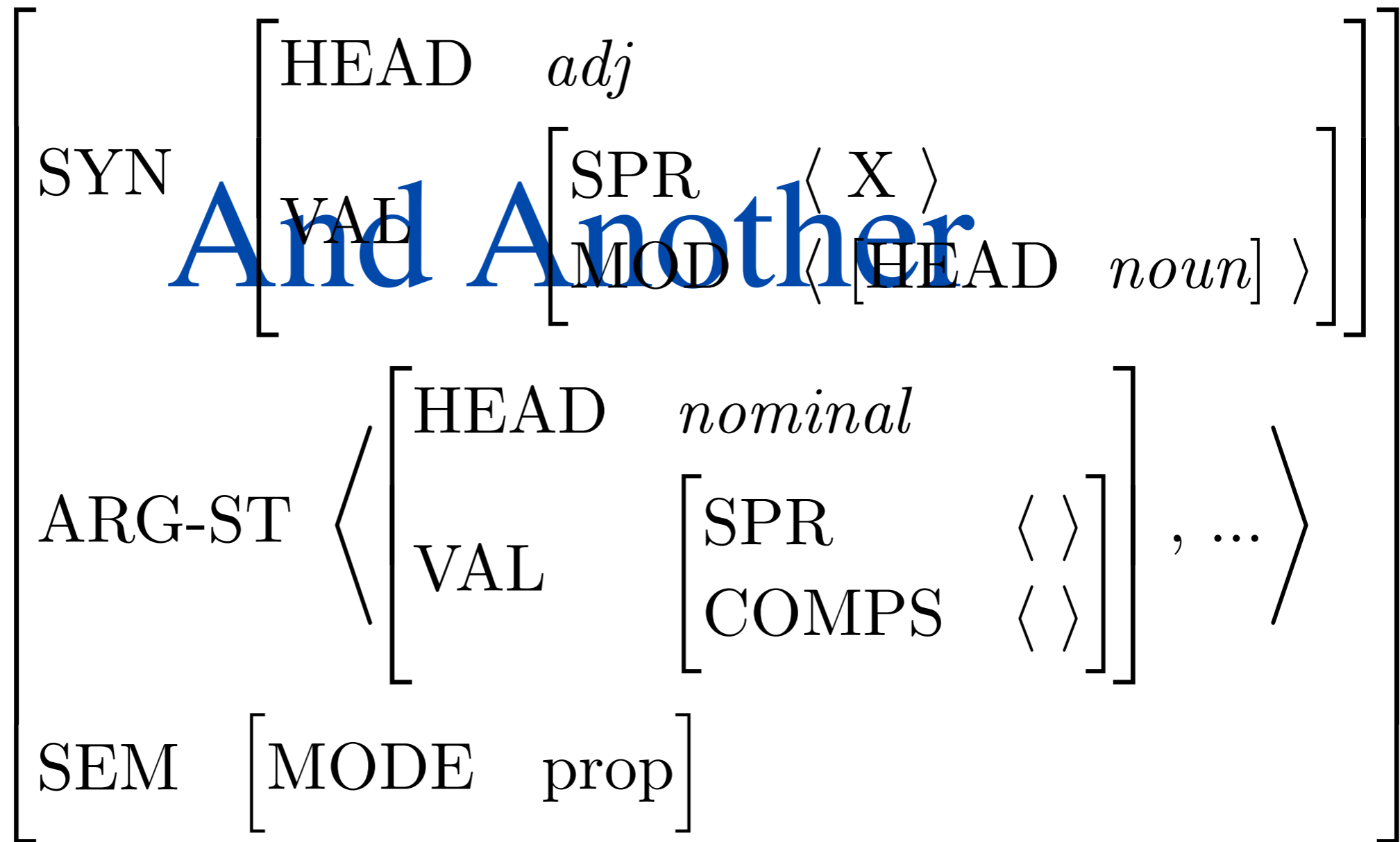

Synsem Types

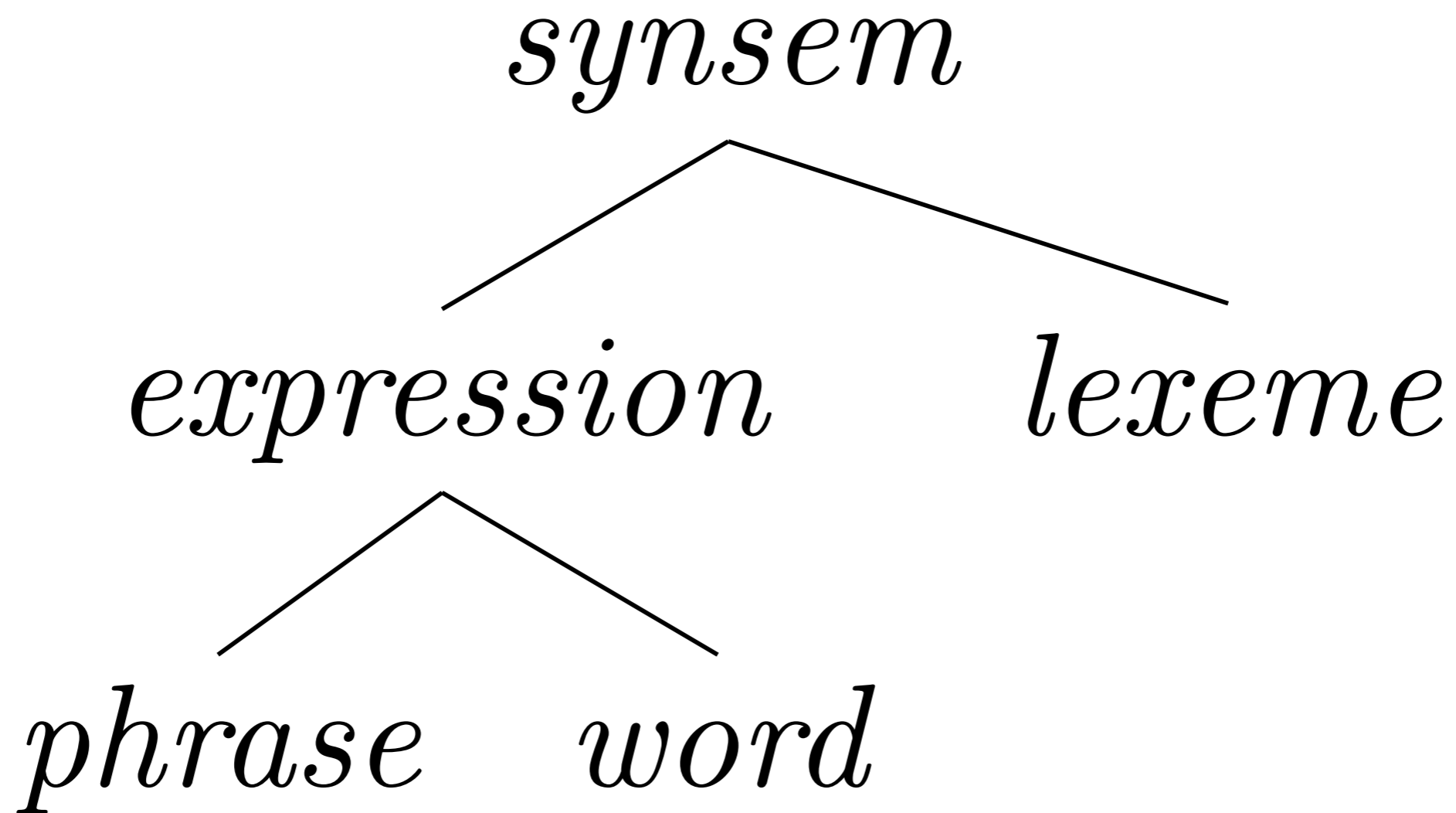

Give ARG-ST a Unique Home

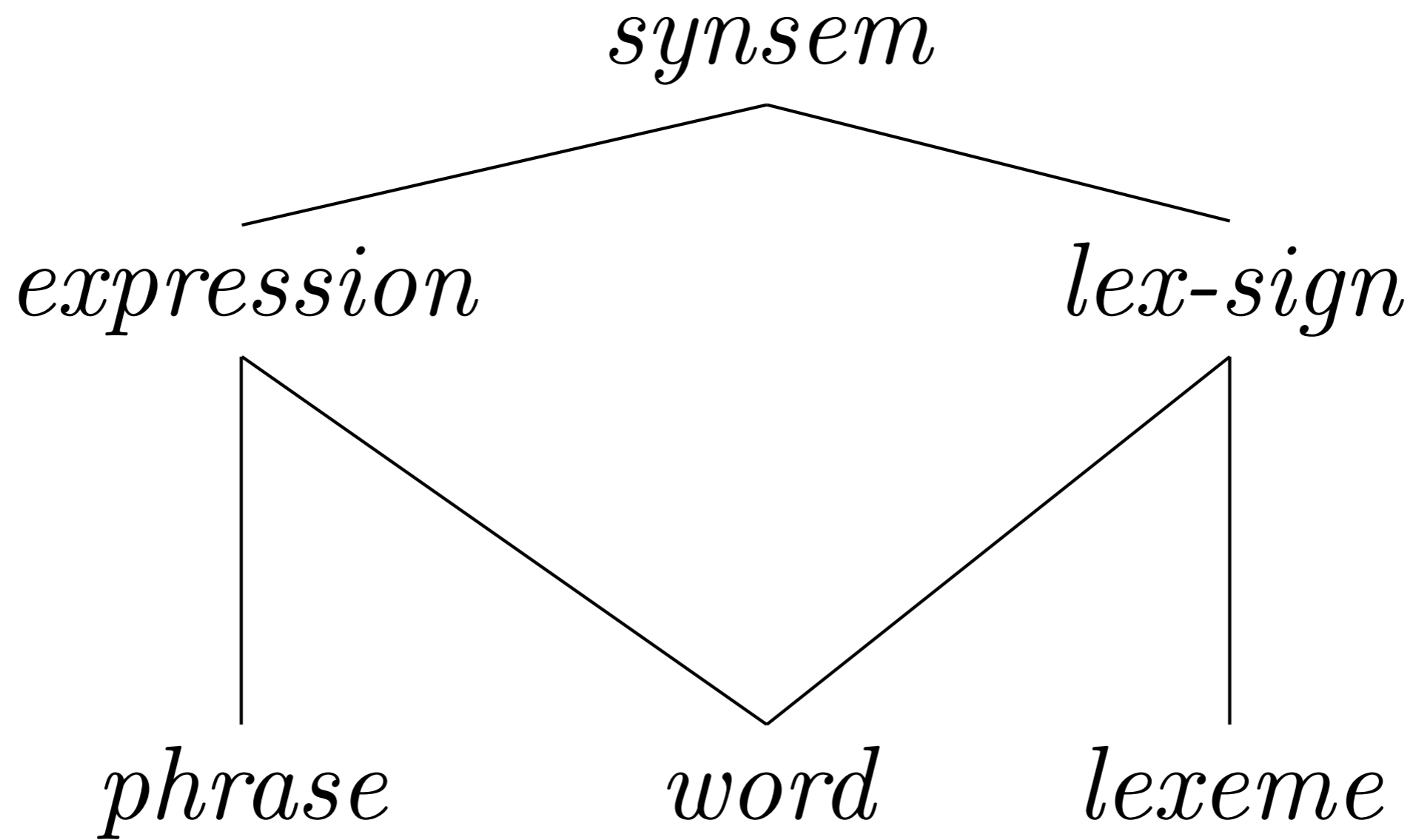

Words and Phrases as Saussurean Signs

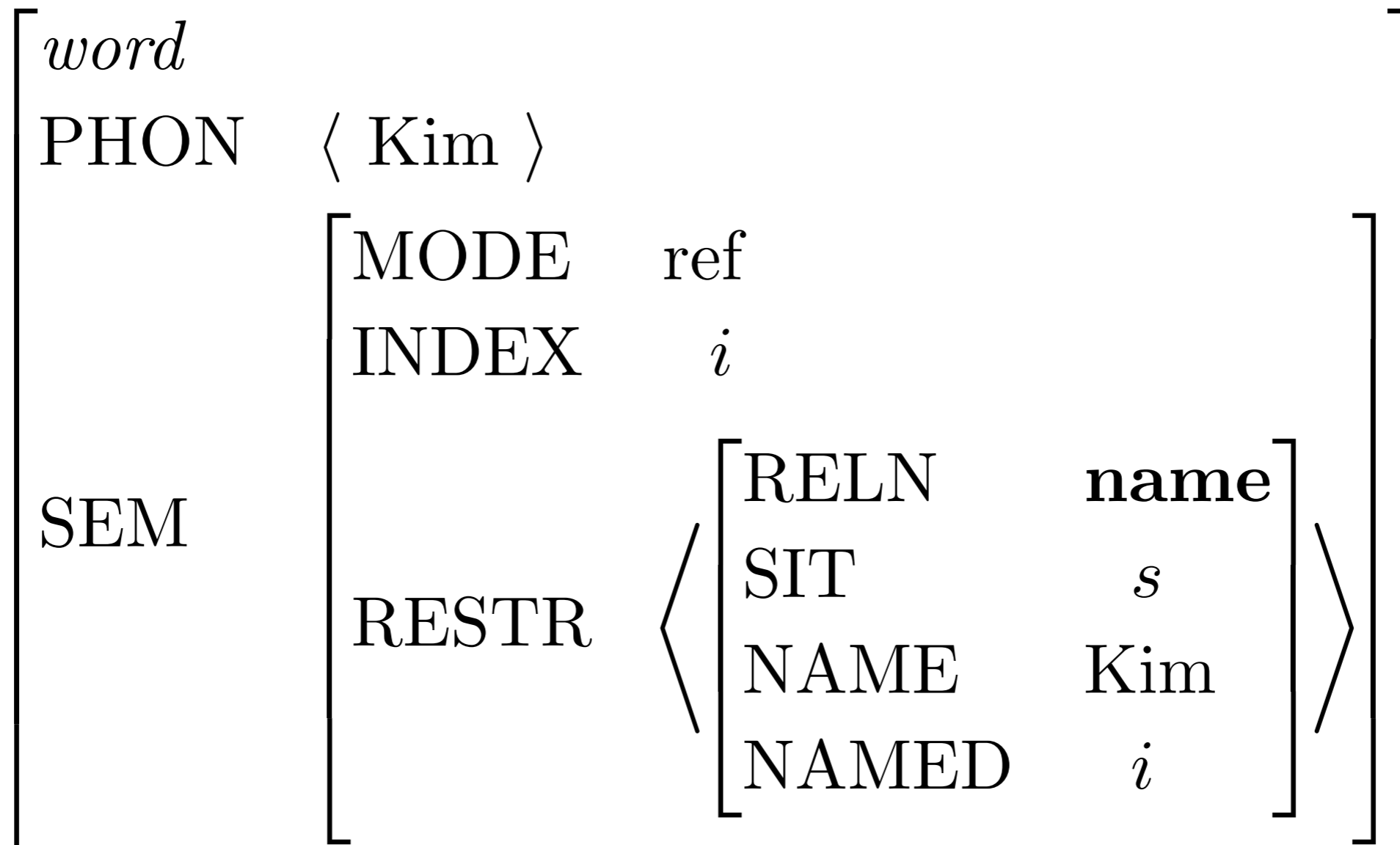

Augmented Signs

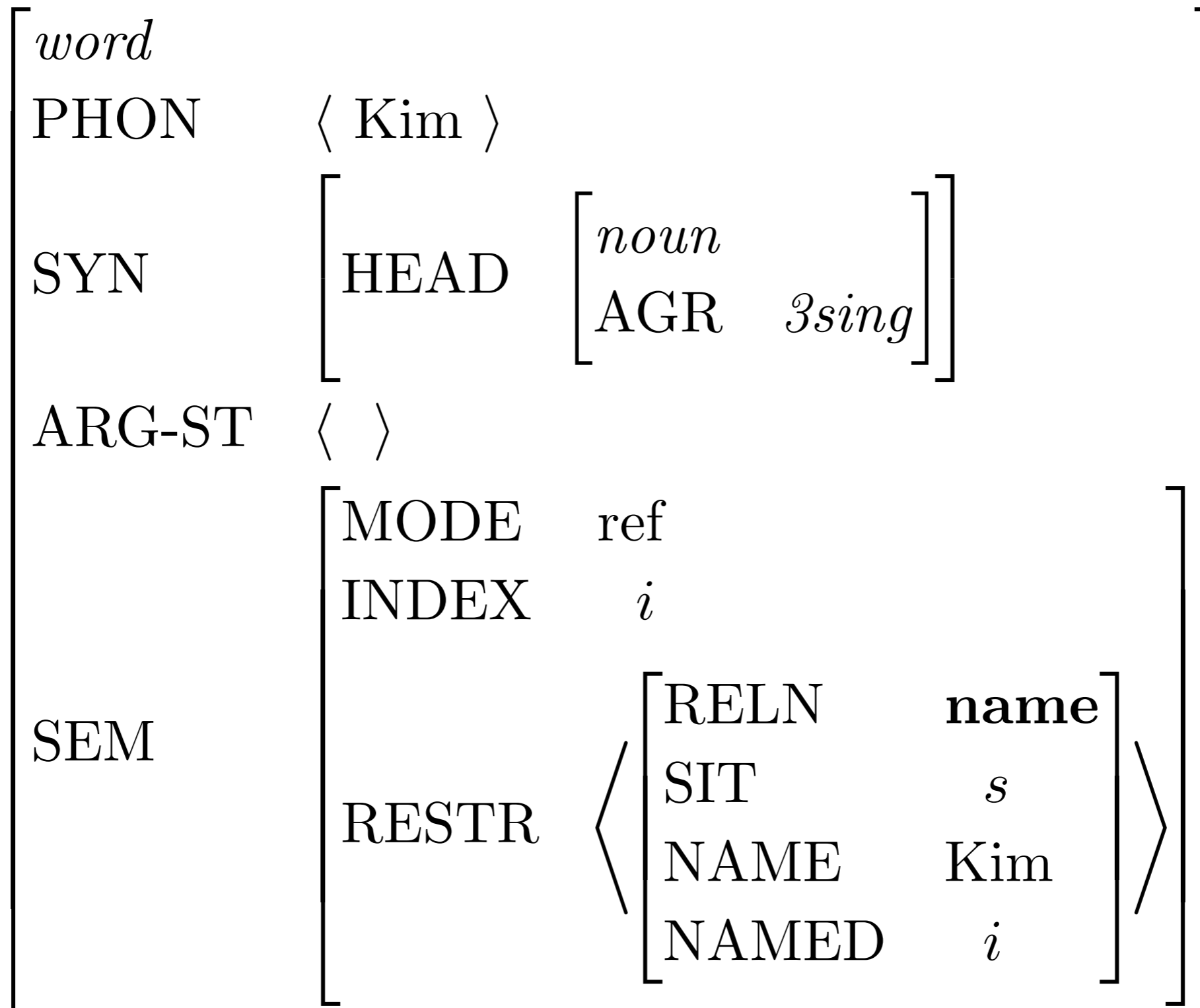

Phrases as Signs

<i>phrase</i>																		
PHON	⟨ Kim , walks ⟩																	
SYN	<table border="0"> <tr> <td>HEAD</td> <td> <table border="0"> <tr> <td><i>verb</i></td> </tr> <tr> <td>FORM fin</td> </tr> </table> </td> </tr> <tr> <td>SPR</td> <td>⟨ ⟩</td> </tr> <tr> <td>COMPS</td> <td>⟨ ⟩</td> </tr> </table>	HEAD	<table border="0"> <tr> <td><i>verb</i></td> </tr> <tr> <td>FORM fin</td> </tr> </table>	<i>verb</i>	FORM fin	SPR	⟨ ⟩	COMPS	⟨ ⟩									
	HEAD	<table border="0"> <tr> <td><i>verb</i></td> </tr> <tr> <td>FORM fin</td> </tr> </table>	<i>verb</i>	FORM fin														
	<i>verb</i>																	
FORM fin																		
SPR	⟨ ⟩																	
COMPS	⟨ ⟩																	
SEM	<table border="0"> <tr> <td>MODE</td> <td>prop</td> </tr> <tr> <td>INDEX</td> <td><i>s</i></td> </tr> </table>	MODE	prop	INDEX	<i>s</i>													
	MODE	prop																
	INDEX	<i>s</i>																
RESTR	<table border="0"> <tr> <td> <table border="0"> <tr> <td>RELN</td> <td>name</td> </tr> <tr> <td>NAME</td> <td>Kim</td> </tr> <tr> <td>NAMED</td> <td><i>i</i></td> </tr> </table> </td> <td>,</td> <td> <table border="0"> <tr> <td>RELN</td> <td>walk</td> </tr> <tr> <td>SIT</td> <td><i>s</i></td> </tr> <tr> <td>WALKER</td> <td><i>i</i></td> </tr> </table> </td> <td>,</td> <td>...</td> </tr> </table>	<table border="0"> <tr> <td>RELN</td> <td>name</td> </tr> <tr> <td>NAME</td> <td>Kim</td> </tr> <tr> <td>NAMED</td> <td><i>i</i></td> </tr> </table>	RELN	name	NAME	Kim	NAMED	<i>i</i>	,	<table border="0"> <tr> <td>RELN</td> <td>walk</td> </tr> <tr> <td>SIT</td> <td><i>s</i></td> </tr> <tr> <td>WALKER</td> <td><i>i</i></td> </tr> </table>	RELN	walk	SIT	<i>s</i>	WALKER	<i>i</i>	,	...
<table border="0"> <tr> <td>RELN</td> <td>name</td> </tr> <tr> <td>NAME</td> <td>Kim</td> </tr> <tr> <td>NAMED</td> <td><i>i</i></td> </tr> </table>	RELN	name	NAME	Kim	NAMED	<i>i</i>	,	<table border="0"> <tr> <td>RELN</td> <td>walk</td> </tr> <tr> <td>SIT</td> <td><i>s</i></td> </tr> <tr> <td>WALKER</td> <td><i>i</i></td> </tr> </table>	RELN	walk	SIT	<i>s</i>	WALKER	<i>i</i>	,	...		
RELN	name																	
NAME	Kim																	
NAMED	<i>i</i>																	
RELN	walk																	
SIT	<i>s</i>																	
WALKER	<i>i</i>																	

Types and Constraints

TYPE	FEATURES/VALUE TYPES	IST
<i>sign</i>	$\left[\begin{array}{ll} \text{PHON} & \textit{list(form)} \\ \text{SYN} & \textit{syn-cat} \\ \text{SEM} & \textit{sem-cat} \end{array} \right]$	<i>feat-struct</i>
<i>expression</i>		<i>sign</i>
<i>lex-sign</i>	$\left[\text{ARG-ST} \quad \textit{list(expression)} \right]$	<i>sign</i>
<i>phrase</i>		<i>expression</i>
<i>word</i>		<i>expression & lex-sign</i>
<i>lexeme</i>		<i>lex-sign</i>

Constructions: Some Abbreviations

<i>cx</i>	<i>construction</i>
<i>l-cx</i>	<i>lexical-construction</i>
<i>d-cx</i>	<i>derivational-construction</i>
<i>i-cx</i>	<i>inflectional-construction</i>
<i>pi-cx</i>	<i>postinflectional-construction</i>
<i>p-cx</i>	<i>phrasal-construction</i>
<i>non-hd-cx</i>	<i>non-headed-construction</i>
<i>hd-cx</i>	<i>headed-construction</i>
<i>coord-cx</i>	<i>coordinate-construction</i>
<i>imp-cx</i>	<i>imperative-construction</i>
<i>hd-fill-cx</i>	<i>head-filler-construction</i>
<i>hd-comp-cx</i>	<i>head-complement-construction</i>
<i>hd-spr-cx</i>	<i>head-specifier-construction</i>
<i>hd-mod-cx</i>	<i>head-modifier-construction</i>

The World of Constructions

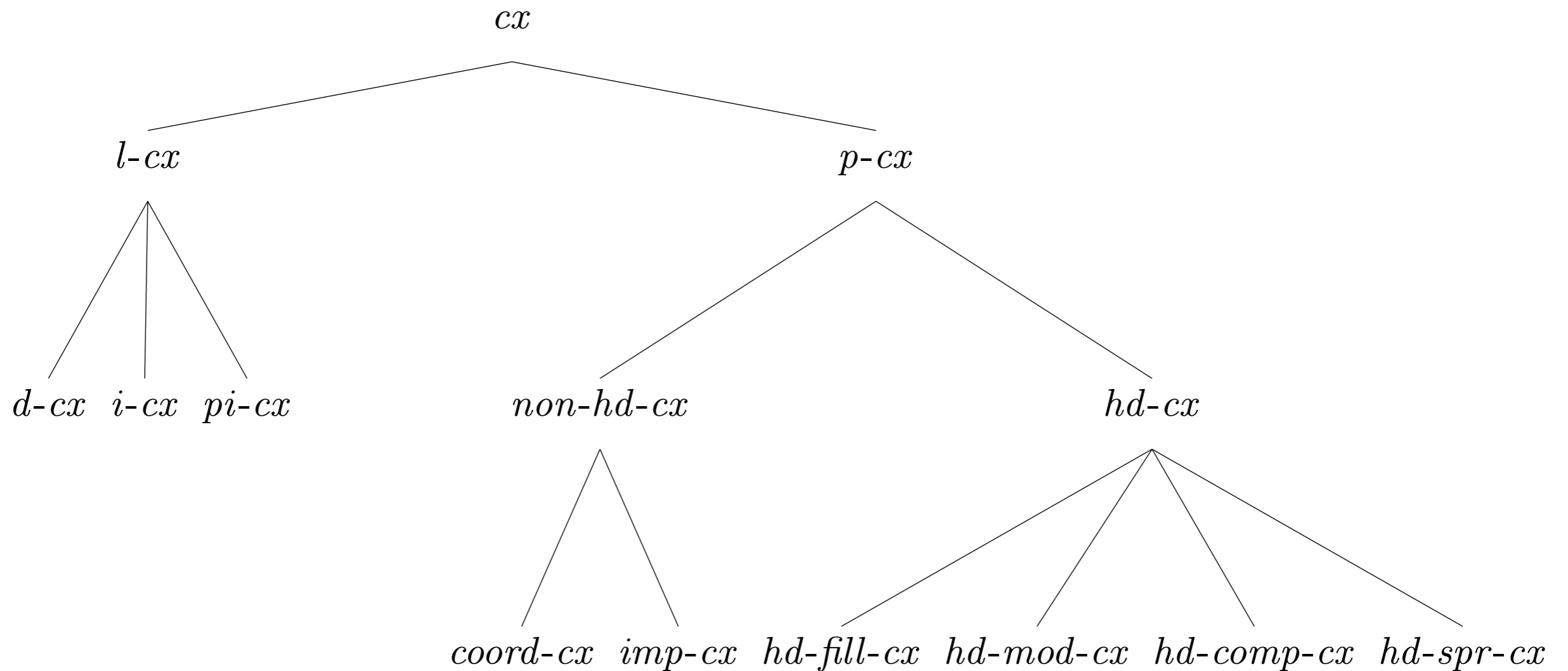

Properties of Constructions

TYPE	FEATURES/VALUE TYPES	IST
<i>cx</i>	$\left[\begin{array}{ll} \text{MOTHER} & \textit{sign} \\ \text{DTRS} & \textit{list}(\textit{sign}) \end{array} \right]$	<i>feat-struct</i>
<i>l-cx</i>	$\left[\begin{array}{ll} \text{MOTHER} & \textit{lex-sign} \\ \text{DTRS} & \langle \textit{lex-sign} \rangle \end{array} \right]$	<i>cx</i>
<i>p-cx</i>	$\left[\begin{array}{ll} \text{MOTHER} & \textit{phrase} \\ \text{DTRS} & \textit{list}(\textit{expression}) \end{array} \right]$	<i>cx</i>

Well-Formed Tree Structure

Φ is a Well-Formed Structure according to a grammar G if and only if

1. there is some construction C in G , such that
2. there is a feature structure I that is an instantiation of C , such that Φ is the value of the MOTHER feature of I .

A Well-Formed Feature Structure

The grammar licenses a feature structure of type *phrase* whose PHON value is $\langle ate, a, pizza \rangle$ because there is a feature structure instantiating the head-complement construction that has that feature structure as its MOTHER value. This phrasal construct satisfies the following description:

$$\left[\begin{array}{l}
 \textit{phrase} \\
 \text{PHON} \quad \langle ate, a, pizza \rangle \\
 \text{SYN} \quad \left[\begin{array}{l}
 \text{HEAD} \quad \left[\begin{array}{l} \textit{verb} \\ \text{FORM} \quad \textit{fin} \end{array} \right] \\
 \text{VAL} \quad \left[\begin{array}{l} \text{SPR} \quad \langle \text{NP} \rangle \\ \text{COMPS} \quad \langle \rangle \\ \text{MOD} \quad \langle \rangle \end{array} \right] \\
 \text{GAP} \quad \langle \rangle
 \end{array} \right] \\
 \text{SEM} \quad \left[\begin{array}{l}
 \text{MODE} \quad \textit{prop} \\
 \text{INDEX} \quad \textit{s} \\
 \text{RESTR} \quad \left\langle \left[\begin{array}{l} \text{RELN} \quad \textit{eat} \\ \text{SIT} \quad \textit{s} \\ \text{EATER} \quad \textit{i} \\ \text{EATEN} \quad \textit{j} \end{array} \right], \left[\begin{array}{l} \text{RELN} \quad \mathbf{a} \\ \text{BV} \quad \textit{j} \end{array} \right], \left[\begin{array}{l} \text{RELN} \quad \mathbf{pizza} \\ \text{INST} \quad \textit{j} \end{array} \right], \right\rangle
 \end{array} \right]
 \end{array} \right]$$

Another Well-Formed Feature Structure

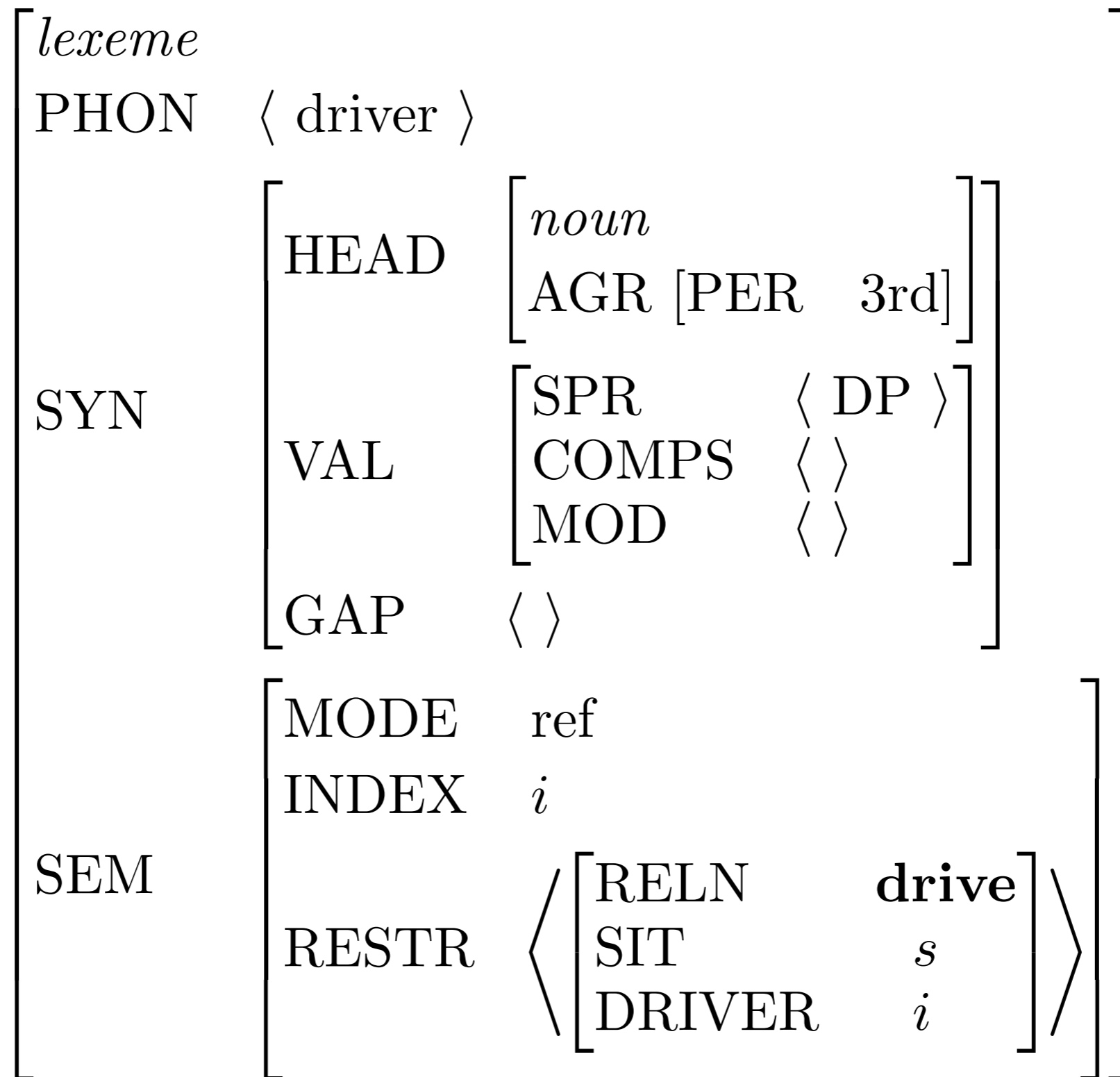

Two Constraints

Root Constraint:

$$\left[\begin{array}{l} \text{SYN} \\ \left[\begin{array}{l} \text{HEAD} \\ \text{VAL} \\ \text{GAP} \end{array} \right. \left. \begin{array}{l} \left[\begin{array}{l} \text{verb} \\ \text{FORM} \quad \text{fin} \end{array} \right] \\ \left[\begin{array}{l} \text{COMPS} \quad \langle \rangle \\ \text{SPR} \quad \langle \rangle \end{array} \right] \\ \langle \rangle \end{array} \right] \end{array} \right]$$

Principle of Order:

$$cx : \left[\begin{array}{l} \text{MOTHER} \quad \left[\text{PHON} \quad \boxed{A1} \oplus \dots \oplus \boxed{An} \right] \\ \text{DTRS} \quad \langle \left[\text{PHON} \quad \boxed{A1} \right], \dots, \left[\text{PHON} \quad \boxed{An} \right] \rangle \end{array} \right]$$

Semantic Compositionality Principle

$$c\mathcal{X} : \left[\begin{array}{l} \text{MOTHER} \quad [\text{SEM} [\text{RESTR} \boxed{A1} \oplus \dots \oplus \boxed{An}]] \\ \text{DTRS} \quad \langle [\text{SEM} [\text{RESTR} \boxed{A1}]], \dots, [\text{SEM} [\text{RESTR} \boxed{An}]] \rangle \end{array} \right]$$

Alternative Version:

$$c\mathcal{X} : \left[\begin{array}{l} \text{MOTHER} \quad [\text{SEM} [\text{RESTR} \boxed{A0} \oplus \boxed{A1} \oplus \dots \oplus \boxed{An}]] \\ \text{DTRS} \quad \langle [\text{SEM} [\text{RESTR} \boxed{A1}]], \dots, [\text{SEM} [\text{RESTR} \boxed{An}]] \rangle \\ \text{CX-SEM} \quad \boxed{A0} \end{array} \right]$$

Head Constructions

Phrasal Constructions of Our Grammar:

TYPE	FEATURES/VALUE TYPES	IST
<i>hd-cx</i>	[HD-DTR <i>sign</i>]	<i>cx</i>

Head Feature Principle:

$$hd-cx : \left[\begin{array}{l} \text{MOTHER} \quad [\text{SYN} \quad [\text{HEAD} \quad \boxed{1}]] \\ \text{HD-DTR} \quad [\text{SYN} \quad [\text{HEAD} \quad \boxed{1}]] \end{array} \right]$$

Two More Principles

Semantic Inheritance Principle:

$$hd-cx : \left[\begin{array}{l} \text{MOTHER} \\ \text{HD-DTR} \end{array} \left[\begin{array}{l} \text{SEM} \\ \text{SEM} \end{array} \left[\begin{array}{l} \text{MODE} \\ \text{INDEX} \end{array} \left[\begin{array}{l} \boxed{1} \\ \boxed{2} \end{array} \right] \right] \right] \right]$$

Valence Principle:

$$hd-cx : \left[\begin{array}{l} \text{MOTHER} \\ \text{HD-DTR} \end{array} \left[\begin{array}{l} \text{[SYN [VAL / } \boxed{1} \text{]]} \\ \text{[SYN [VAL / } \boxed{1} \text{]]} \end{array} \right] \right]$$

The GAP Principle

hd-cx:

$$\left[\begin{array}{l} \text{MOTHER} \\ \text{HD-DTR} \\ \text{DTRS} \end{array} \begin{array}{l} [\text{SYN} [\text{GAP} (\boxed{A1} \oplus \dots \oplus \boxed{An}) \ominus \boxed{A0}]] \\ [\text{SYN} [\text{STOP-GAP} \boxed{A0}]] \\ \langle [\text{SYN} [\text{GAP} \boxed{A1}]] , \dots , [\text{SYN} [\text{GAP} \boxed{An}]] \rangle \end{array} \right]$$

The Head-Complement Construction

$$hd-comp-cx : \left[\begin{array}{l} \text{MOTHER} \quad [\text{SYN} \quad [\text{VAL} \quad [\text{COMPS} \quad \langle \rangle]]] \\ \text{HD-DTR} \quad \boxed{0} \left[\begin{array}{l} \textit{word} \\ \text{SYN} \quad [\text{VAL} \quad [\text{COMPS} \quad \boxed{A}]] \end{array} \right] \\ \text{DTRS} \quad \langle \boxed{0} \rangle \oplus \boxed{A} \textit{nelist} \end{array} \right]$$

And with inherited constraints...

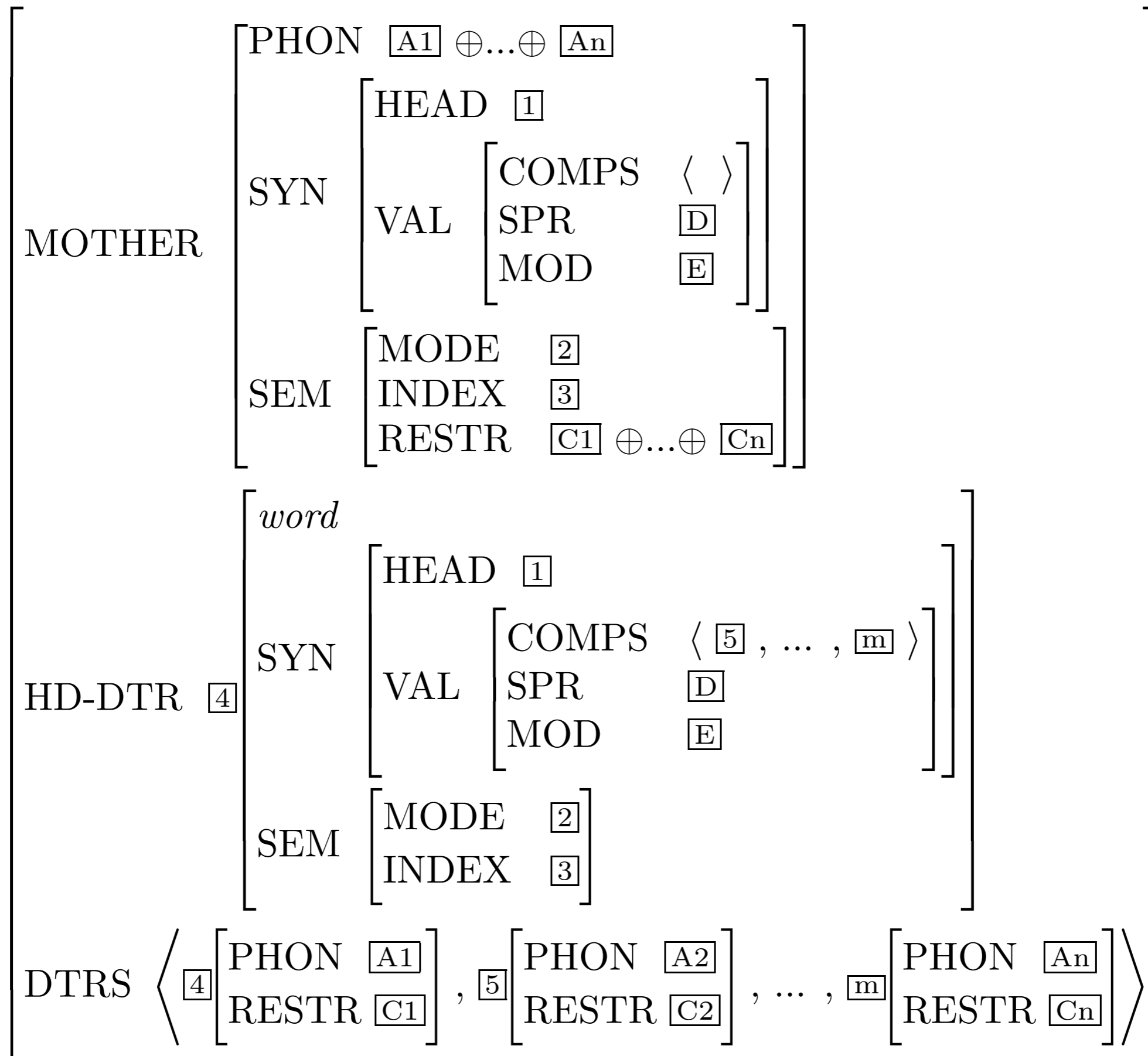

An Instance of the HCC

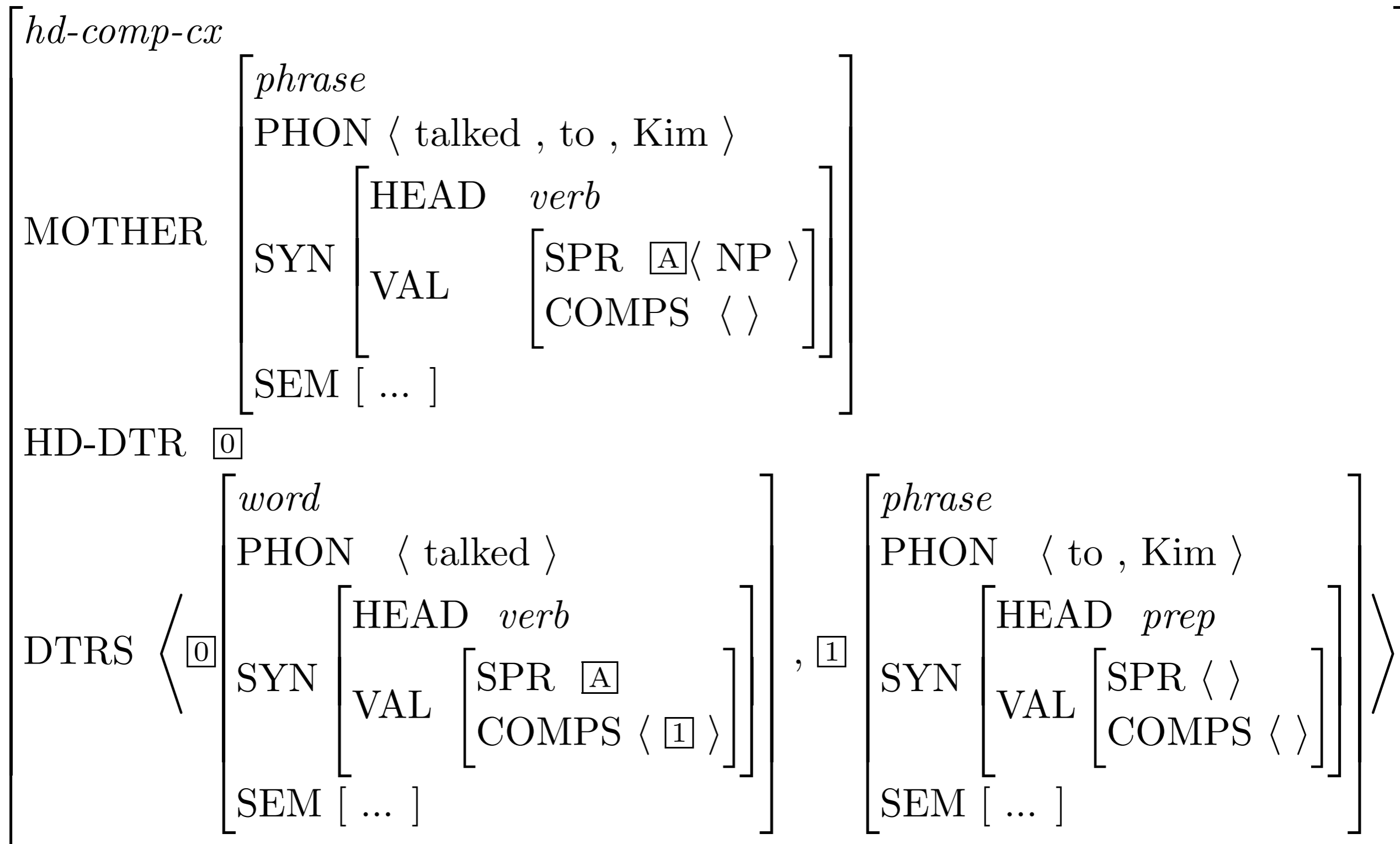

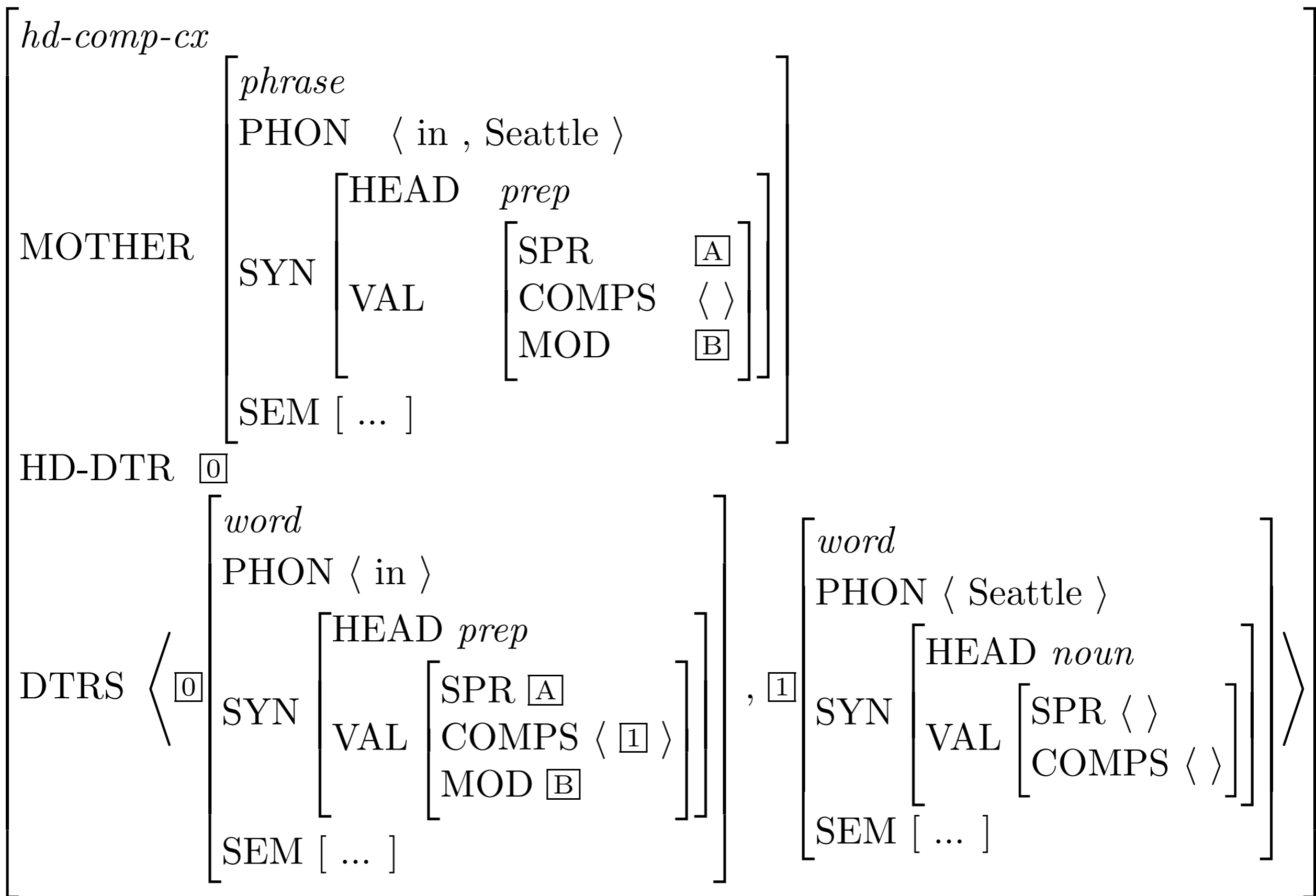

Two More Constructions

$$\textit{hd-spr-cx} : \left[\begin{array}{l} \text{MOTHER} \left[\text{SYN} \left[\text{SPR} \langle \rangle \right] \right] \\ \text{HD-DTR} \boxed{0} \left[\text{SYN} \left[\begin{array}{l} \text{SPR} \langle \boxed{1} \rangle \\ \text{COMPS} \langle \rangle \\ \text{STOP-GAP} \langle \rangle \end{array} \right] \right] \\ \text{DTRS} \langle \boxed{1}, \boxed{0} \rangle \end{array} \right]$$

$$\textit{hd-mod-cx} : \left[\begin{array}{l} \text{HD-DTR} \boxed{1} \left[\text{SYN} \left[\begin{array}{l} \text{VAL} \left[\text{COMPS} \langle \rangle \right] \\ \text{STOP-GAP} \langle \rangle \end{array} \right] \right] \\ \text{DTRS} \left\langle \boxed{1}, \left[\text{SYN} \left[\begin{array}{l} \text{VAL} \left[\begin{array}{l} \text{COMPS} \langle \rangle \\ \text{MOD} \langle \boxed{1} \rangle \end{array} \right] \right] \right] \right\rangle \end{array} \right]$$

A Tree

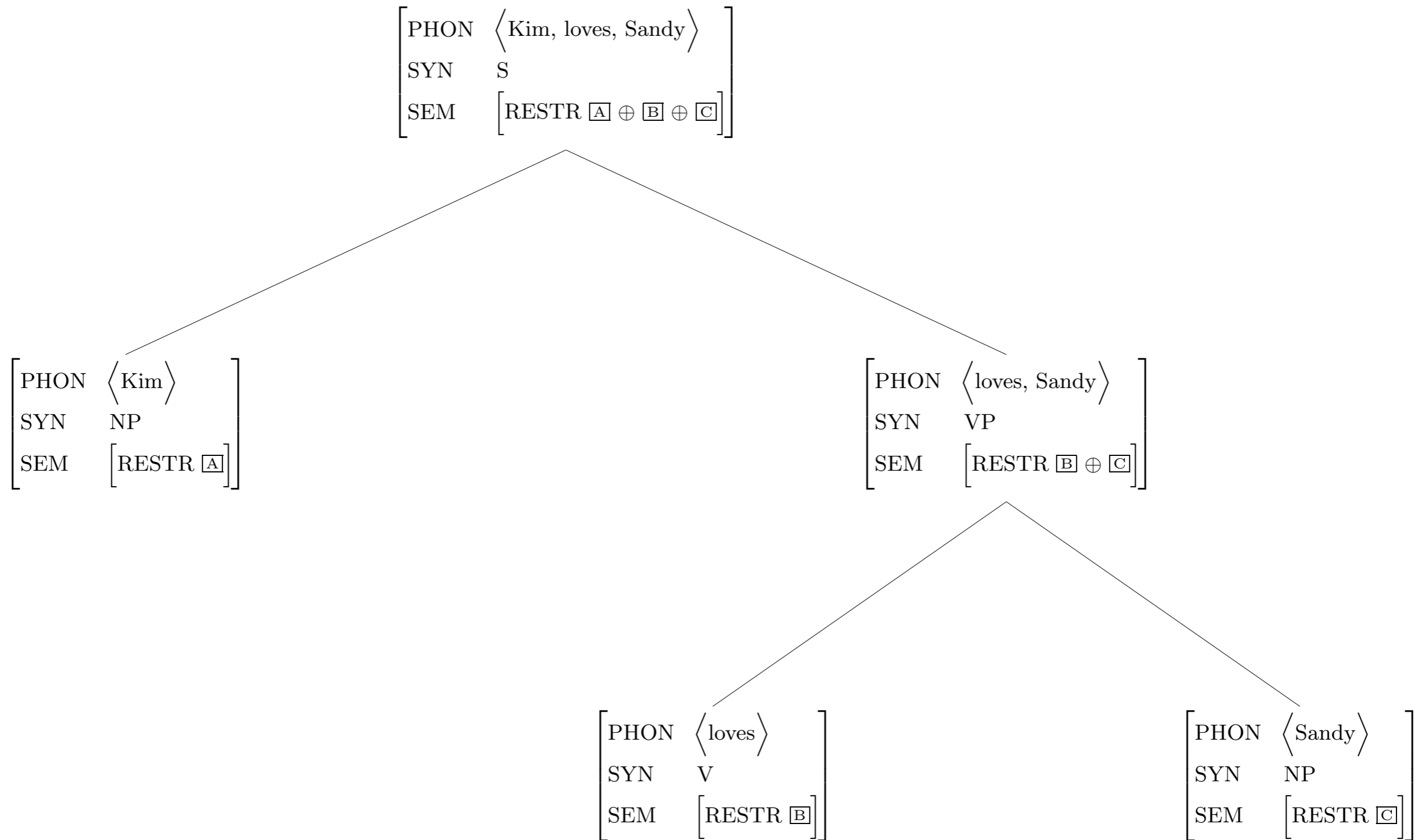

The Head-Filler Construction

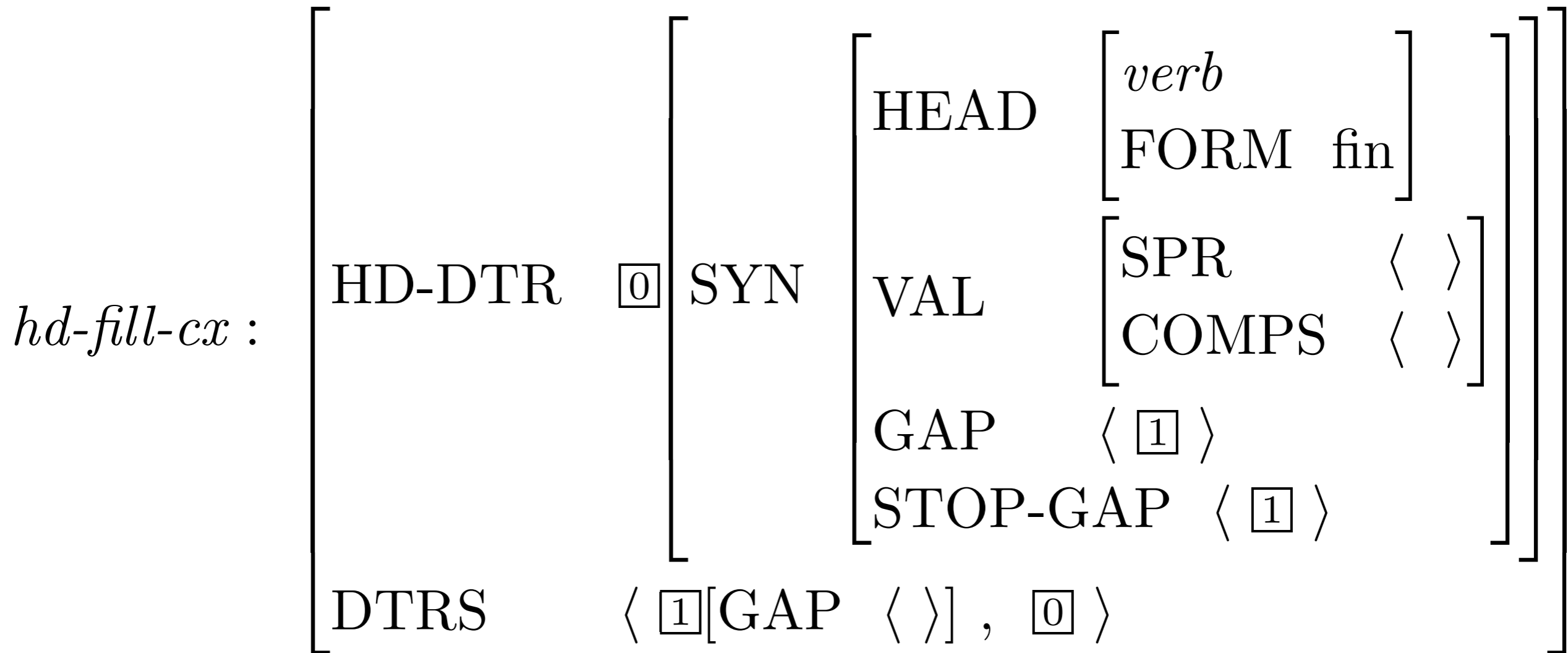

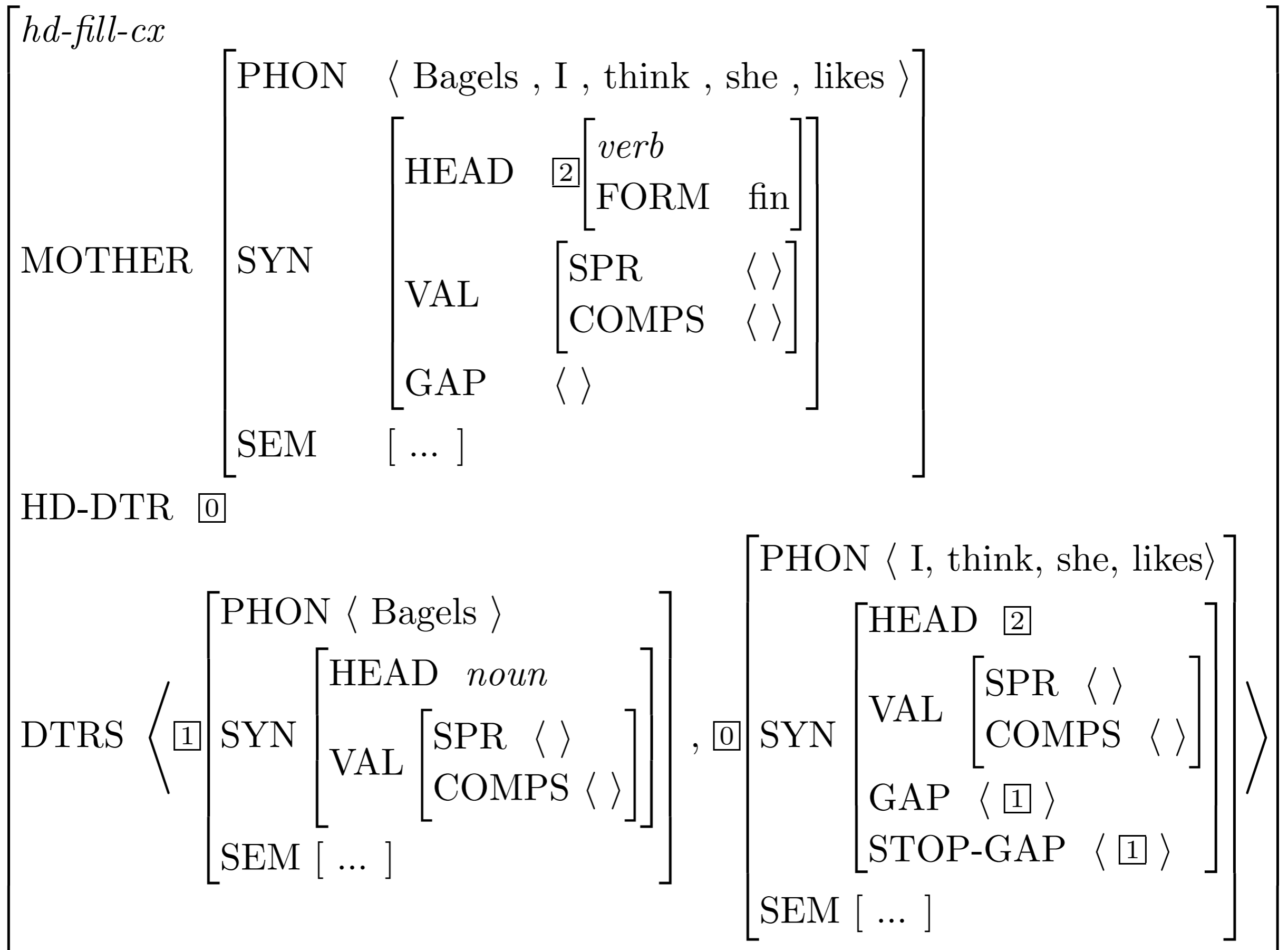

The Imperative Construction

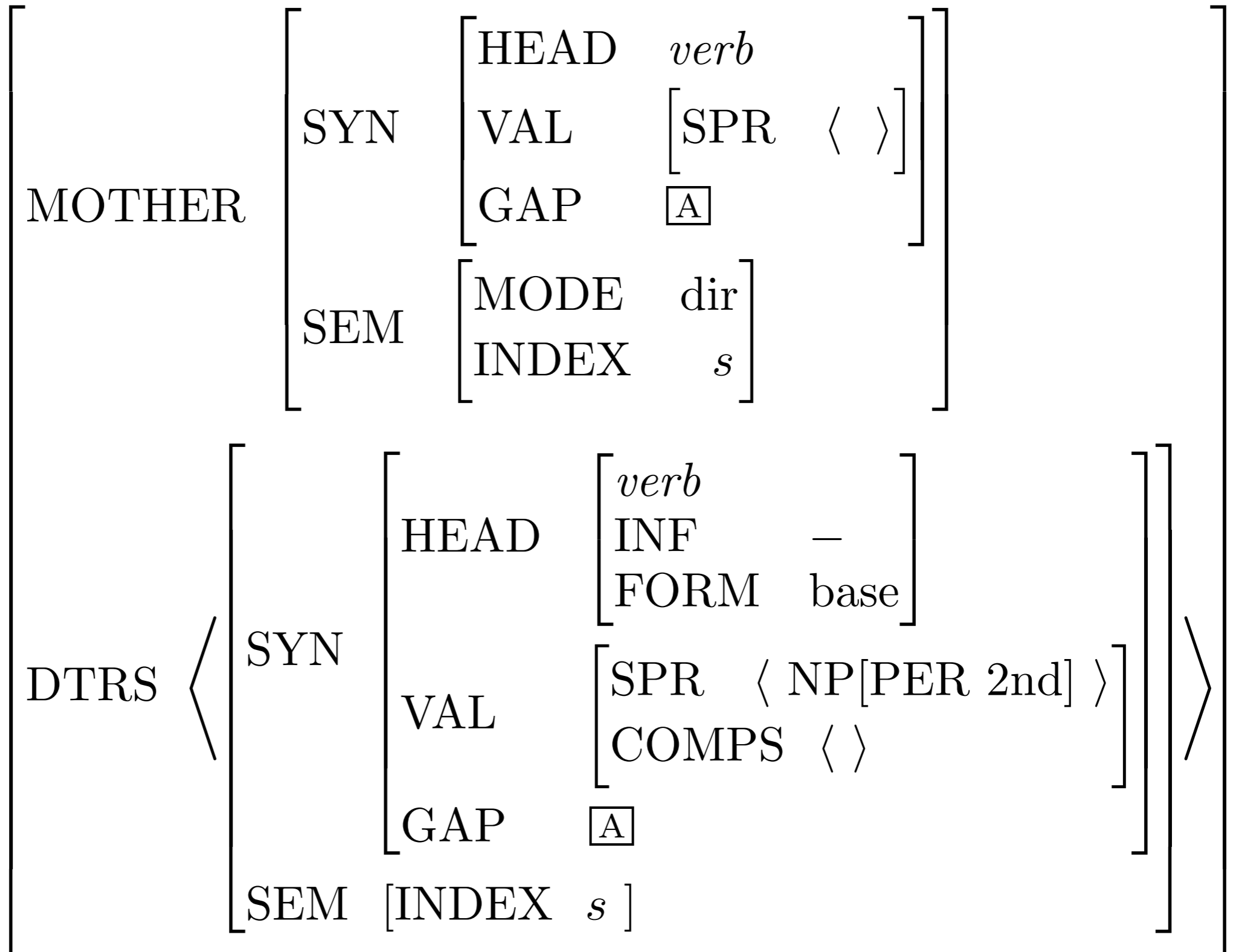

Coordination Construction

$$\left[\begin{array}{l}
 \text{MOTHER} \left[\begin{array}{l}
 \text{HEAD} \text{ [FORM 1]} \\
 \text{SYN} \left[\begin{array}{l}
 \text{VAL} \text{ [2]} \\
 \text{GAP} \text{ [A]}
 \end{array} \right] \\
 \text{SEM} \text{ [IND } s_0]
 \end{array} \right] \\
 \\
 \text{DTRS} \left\langle \left[\begin{array}{l}
 \text{HEAD} \text{ [FORM 1]} \\
 \text{SYN} \left[\begin{array}{l}
 \text{VAL} \text{ [2]} \\
 \text{GAP} \text{ [A]}
 \end{array} \right] \\
 \text{SEM} \text{ [IND } s_1]
 \end{array} \right] \dots \left[\begin{array}{l}
 \text{HEAD} \text{ [FORM 1]} \\
 \text{SYN} \left[\begin{array}{l}
 \text{VAL} \text{ [2]} \\
 \text{GAP} \text{ [A]}
 \end{array} \right] \\
 \text{SEM} \text{ [IND } s_{n-1}]
 \end{array} \right] \right\rangle , \\
 \\
 \left[\begin{array}{l}
 \text{HEAD } conj \\
 \text{IND } s_0 \\
 \text{RESTR} \left\langle \left[\text{ARGS} \langle s_1 \dots s_n \rangle \right] \right\rangle \right] , \left[\begin{array}{l}
 \text{HEAD} \text{ [FORM 1]} \\
 \text{SYN} \left[\begin{array}{l}
 \text{VAL} \text{ [2]} \\
 \text{GAP} \text{ [A]}
 \end{array} \right] \\
 \text{SEM} \text{ [IND } s_n]
 \end{array} \right] \right\rangle
 \end{array} \right]$$

$$\left[\begin{array}{l}
\text{MOTHER} \left[\begin{array}{l}
\text{PHON} \langle \text{Kim} , \text{sleeps} , \text{and} , \text{Pat} , \text{works} \rangle \\
\text{SYN} \left[\begin{array}{l}
\text{HEAD} \textit{verb} \\
\text{VAL} \left[\begin{array}{l}
\text{SPR} \langle \rangle \\
\text{COMPS} \langle \rangle
\end{array} \right]
\end{array} \right] \\
\text{SEM} [\dots]
\end{array} \right] \\
\text{DTRS} \langle \left[\begin{array}{l}
\text{PHON} \langle \text{Kim} , \text{sleeps} \rangle \\
\text{SYN} \left[\begin{array}{l}
\text{HEAD} \textit{verb} \\
\text{VAL} \left[\begin{array}{l}
\text{SPR} \langle \rangle \\
\text{COMPS} \langle \rangle
\end{array} \right]
\end{array} \right] \\
\text{SEM} [\dots]
\end{array} \right] , \left[\begin{array}{l}
\text{PHON} \langle \text{and} \rangle \\
\text{SYN} \left[\text{HEAD} \textit{conj} \right] \\
\text{SEM} [\dots]
\end{array} \right] , \\
\left[\begin{array}{l}
\text{PHON} \langle \text{Pat} , \text{works} \rangle \\
\text{SYN} \left[\begin{array}{l}
\text{HEAD} \textit{verb} \\
\text{VAL} \left[\begin{array}{l}
\text{SPR} \langle \rangle \\
\text{COMPS} \langle \rangle
\end{array} \right]
\end{array} \right] \rangle \\
\text{SEM} [\dots]
\end{array} \right]
\end{array} \right]$$

Some More Abbreviations

<i>imp-cl</i>	<i>imperative-clause</i>
<i>decl-cl</i>	<i>declarative-clause</i>
<i>simp-decl-cl</i>	<i>simple-declarative-clause</i>
<i>top-cl</i>	<i>topicalized-clause</i>
<i>wh-rel-cl</i>	<i>wh-relative-clause</i>
<i>wh-int-cl</i>	<i>wh-interrogative-clause</i>
<i>core-cl</i>	<i>core-clause</i>

A Construction Hierarchy

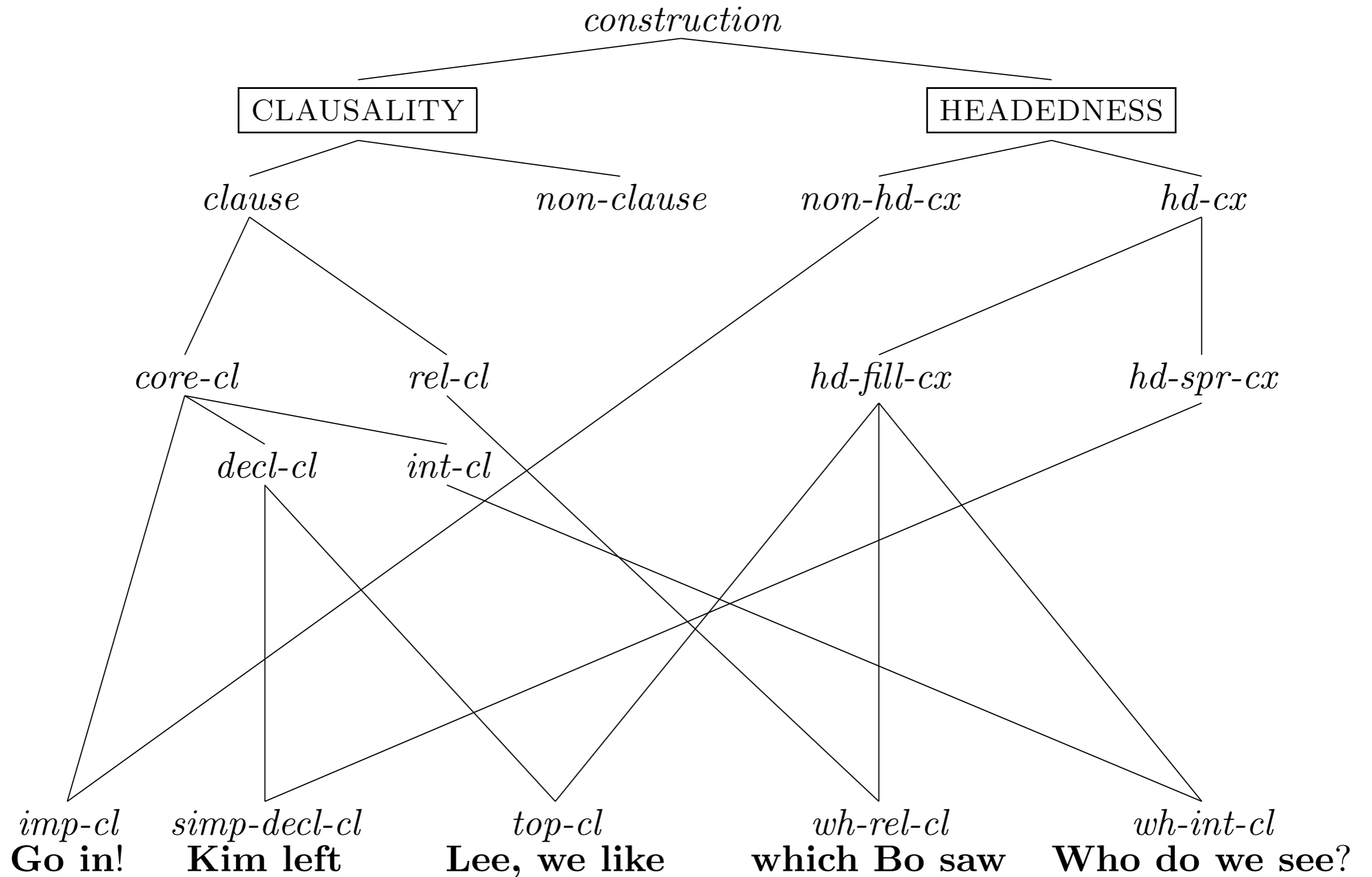

Locality

- Like CFG rules, constructions involve only mothers and daughters.
- A lexical head can place constraints on its sisters or on an appropriate maternal dependent.
- Unbounded dependencies are localized.
Sandy is hard ((for us) to continue) to please_____
Getting it done is hard for us to imagine them considering_____
- Our principles provide a theory of what information (reflected in terms of HEAD, VAL, GAP, etc.) is passed up within the domain projected by a lexical head (including subjects and modifiers) and hence a theory of what information is locally accessible at any given point in a tree.

Course overview

- Survey of some phenomena central to syntactic theory
- Introduction to the HPSG framework
- Process over product: How to build a grammar fragment
- Value of precise formulation (and of getting a computer to do the tedious part for you!)

Reflection

- What was the most surprising thing in this class?
- What do you think is most likely wrong?
- What do you think is the coolest result?
- What do you think you're most likely to remember?

Overview

Final exam posted