

Ling 566
Nov 24, 2015

Auxiliaries cont: NICE

Overview

- Brief review of our analysis so far
- NICE properties of auxiliaries
- The auxiliary *do*
- NICE properties (lexical rules)
- Reading questions

Descriptive Summary of the NICE Properties

Negation

Sentences are negated by putting *not* after the first auxiliary verb; they can be reaffirmed by putting *too* or *so* in the same position

Inversion

Questions are formed by putting an auxiliary verb before the subject NP

Contraction

Auxiliary verbs take negated forms, with *n't* affixed

Ellipsis

Verb phrases immediately following an auxiliary verb can be omitted

Negation (and Reaffirmation)

- Polar adverbs (sentential *not*, *so*, and *too*) appear immediately following an auxiliary

Pat will not leave

Pat will SO leave

Pat will TOO leave

- What about examples like *Not many people left*?

- What happens when you want to deny or reaffirm a sentence with no auxiliary?

Pat left

Pat did not leave

Pat did TOO leave

The Auxiliary *do*

- Like modals, auxiliary *do* only occurs in finite contexts:
**Pat continued to do not leave*
- Unlike modals, *do* cannot be followed by other auxiliaries:
**Pat did not have left*

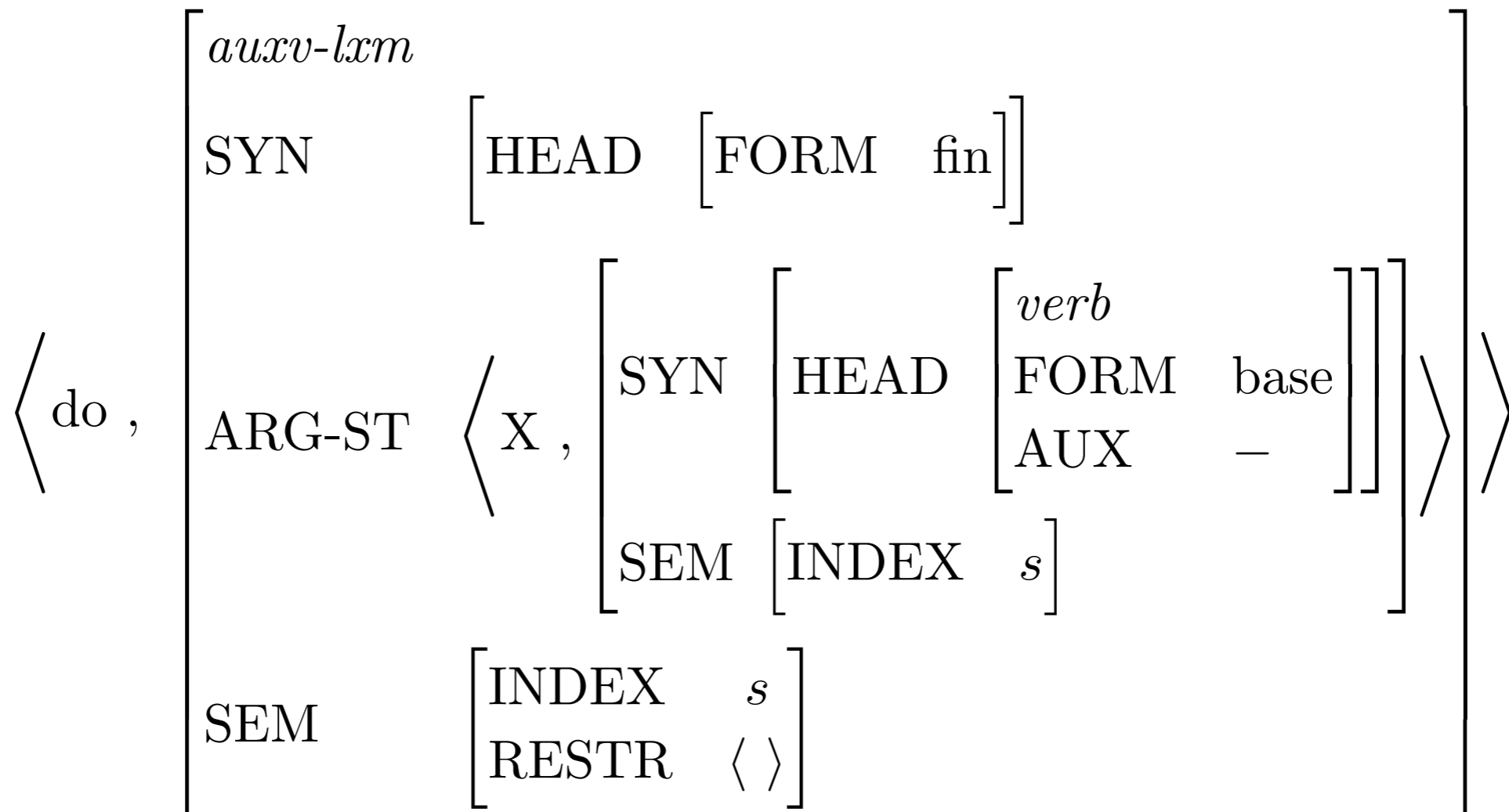

The ADV_{pol} -Addition Lexical Rule

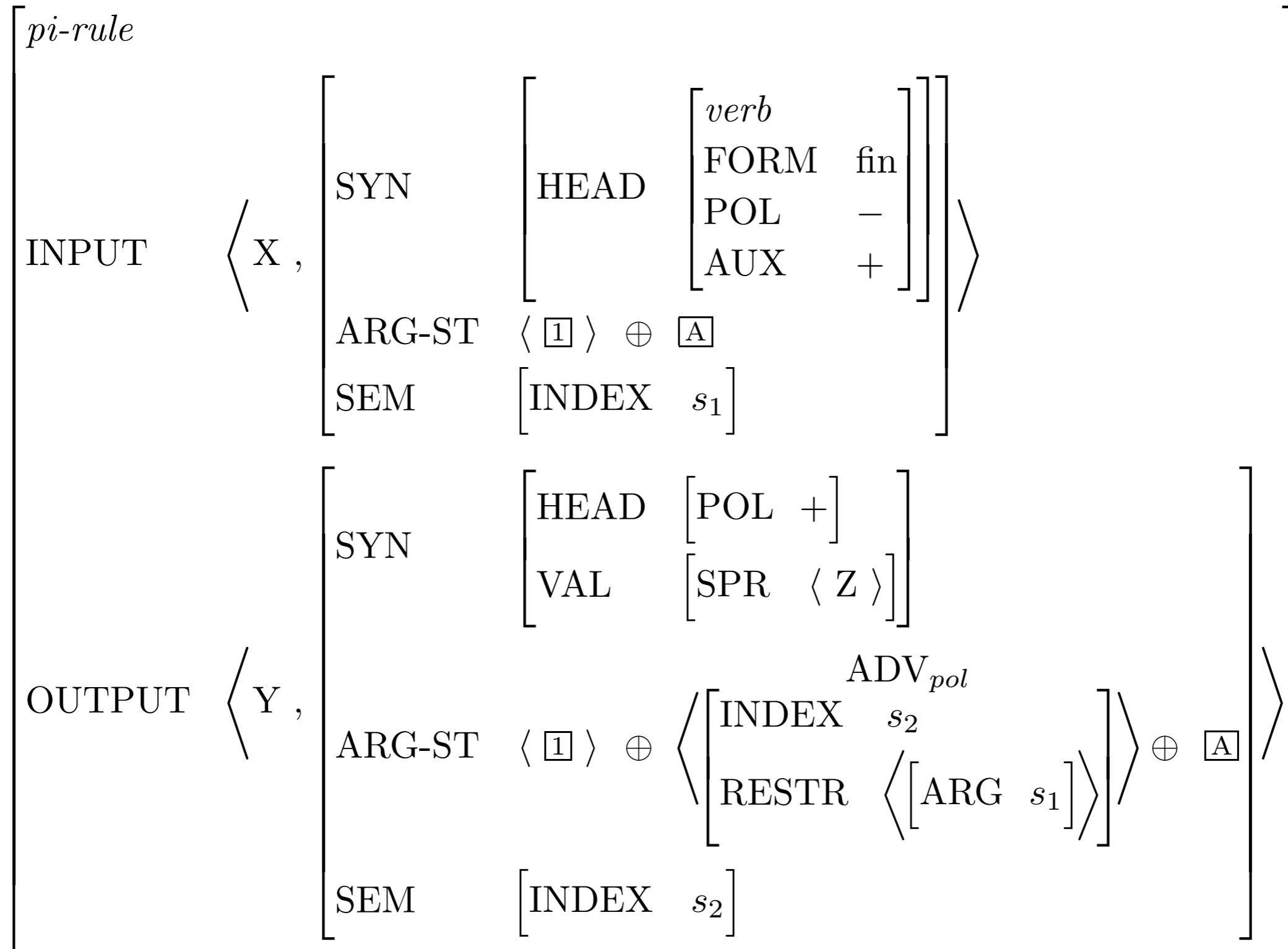

What does the type *pi-rule* mean?

- It maps words to words (hence, “post-inflectional”)
- It preserves MOD values, HEAD values as a default, and (like other lexical rule types) SEM values as a default

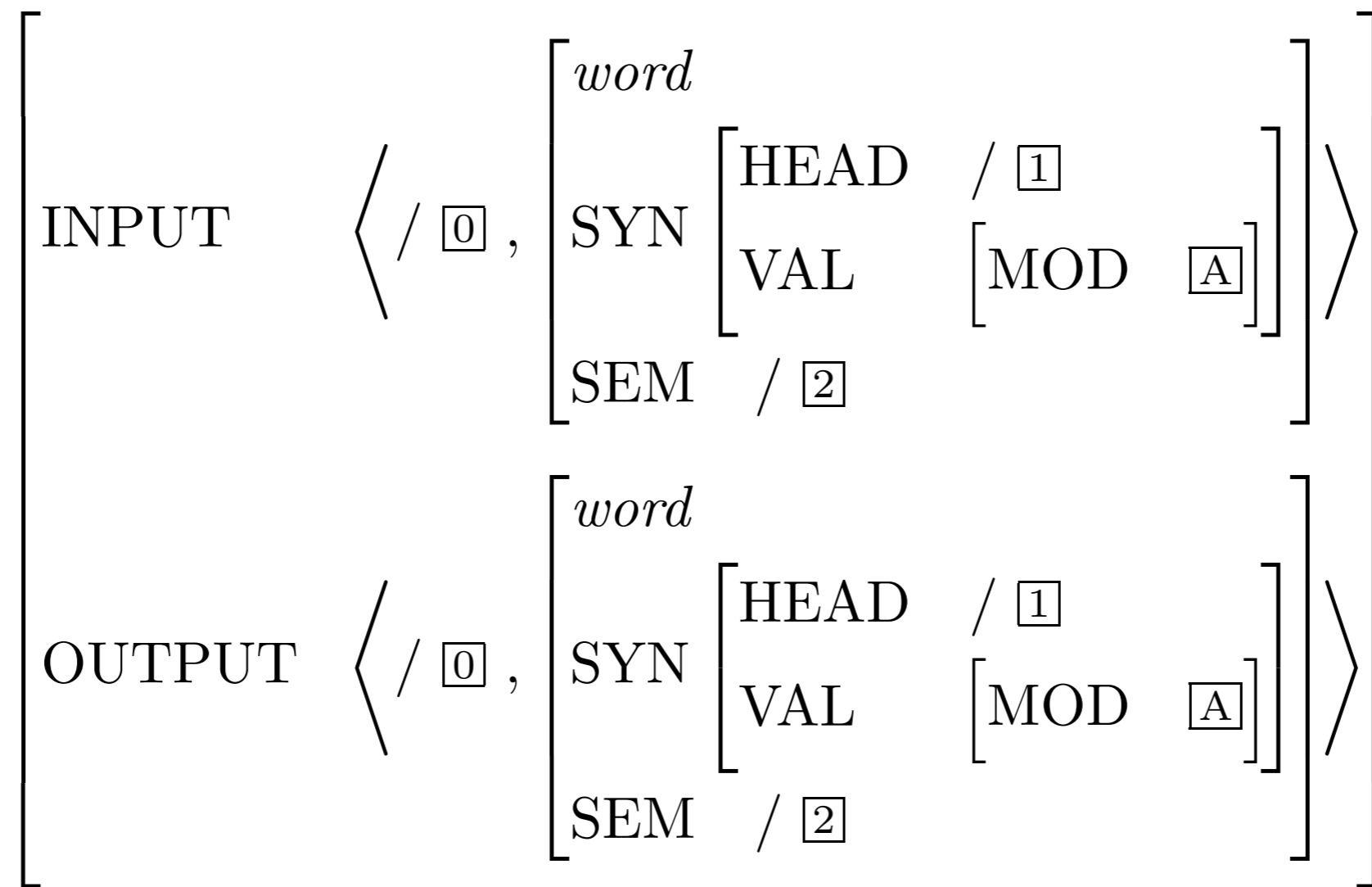

Why doesn't ADV_{pol} -Addition LR mention VAL?

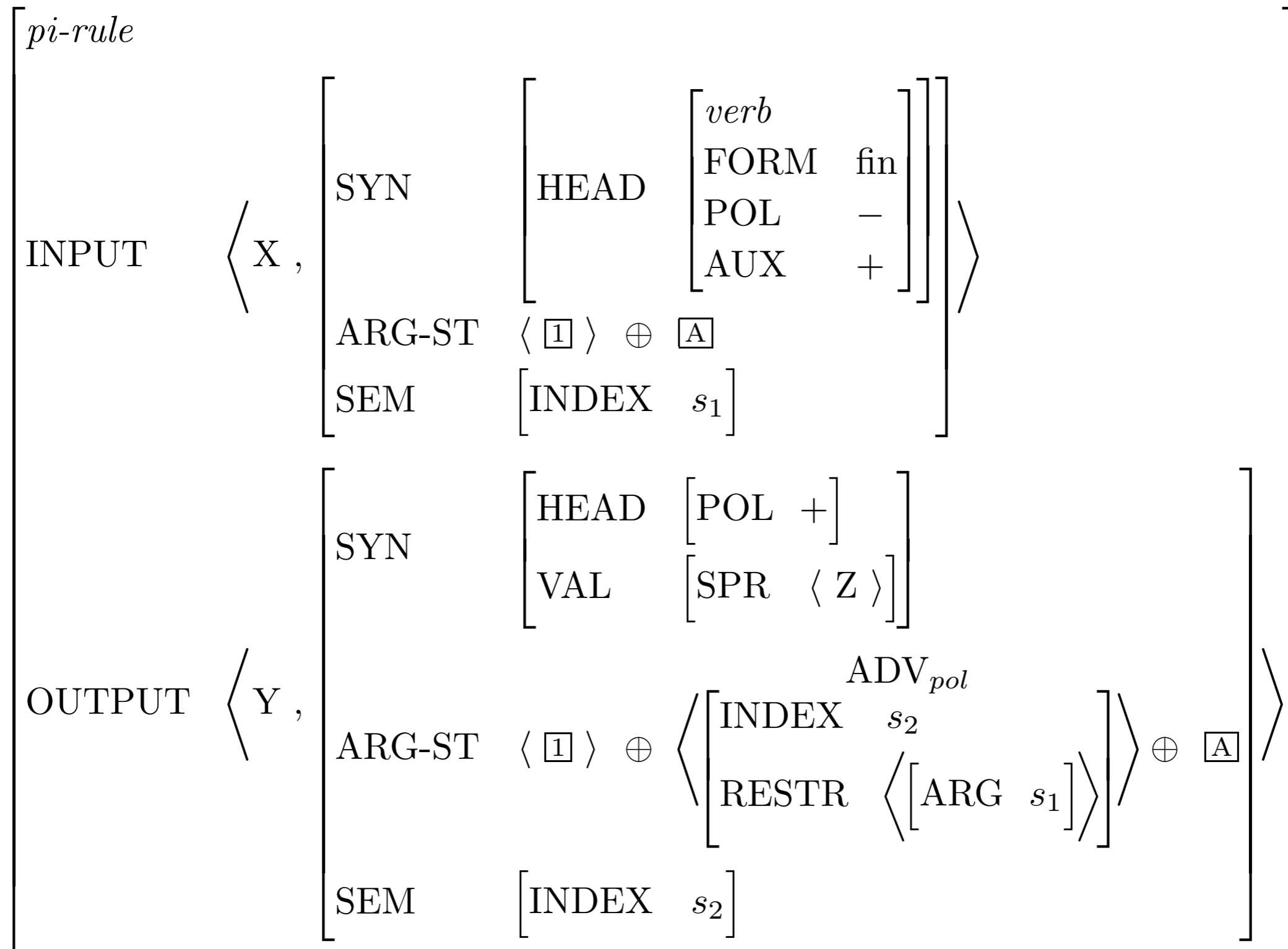

What is the role of these indices?

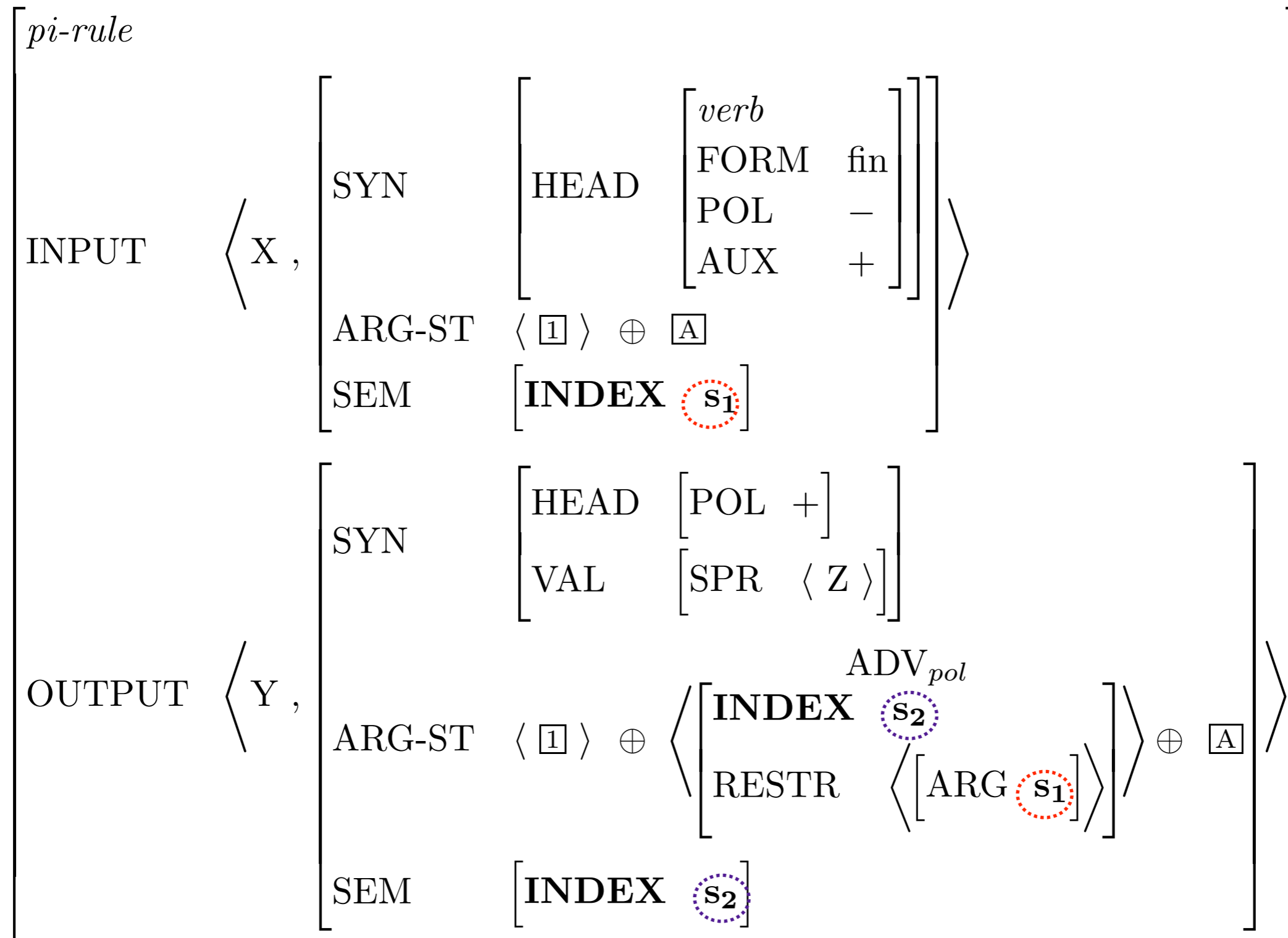

Which *nots* does the rule license?

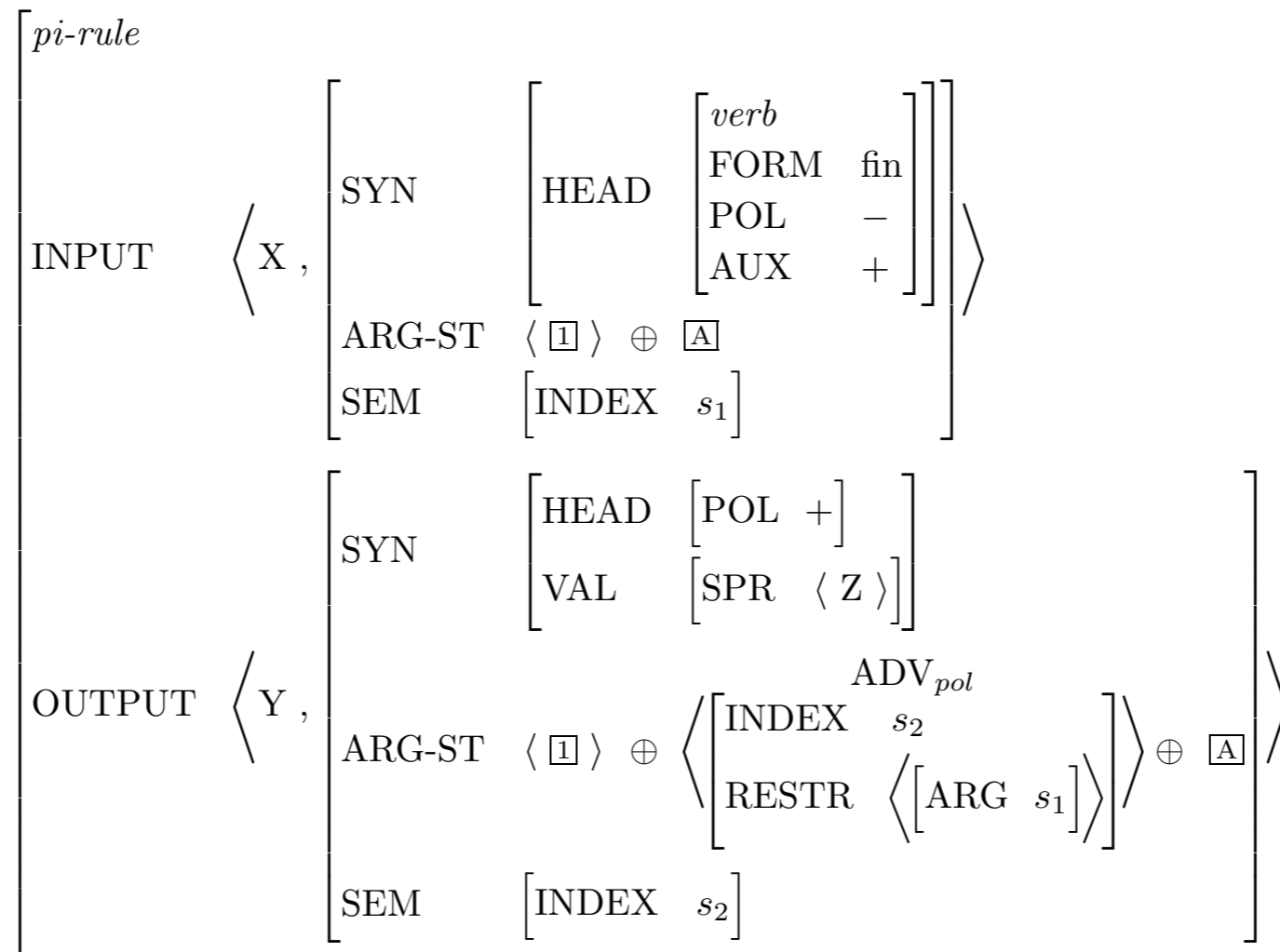

Andy must not have been sleeping?

✓

Andy must have not been sleeping?

✗

Andy must have been not sleeping?

✗

Kleptomaniacs cannot not steal.

✓

Kleptomaniacs cannot not steal.

✗

Negation and Reaffirmation: A Sample Tree

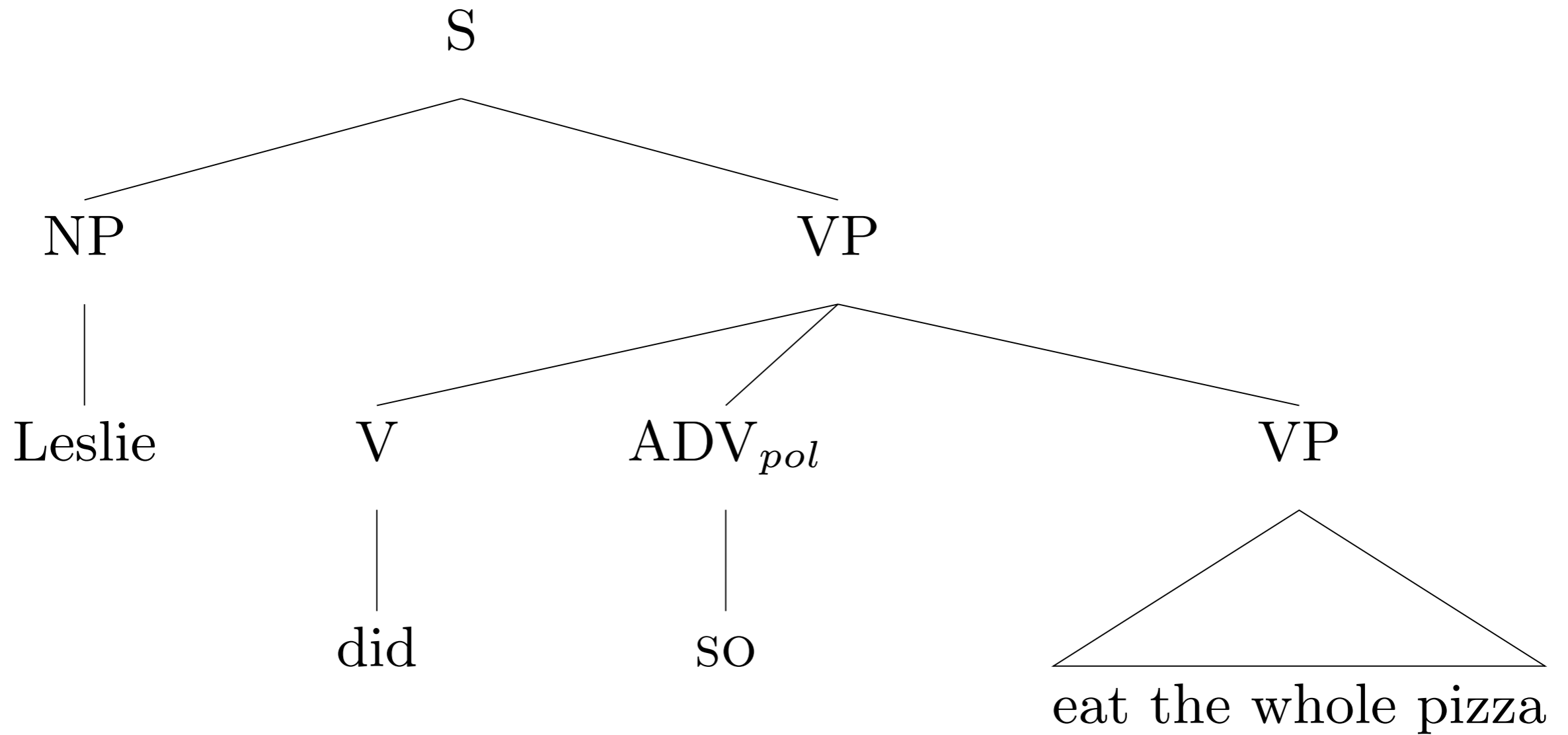

Inversion

- Yes-no questions begin with an auxiliary:
Will Robin win?
- The NP after the auxiliary has all the properties of a subject
 - Agreement: *Have they left?* vs. **Has they left?*
 - Case: **Have them left?*
 - Raising: *Will there continue to be food at the meetings?*
- What happens if you make a question out of a sentence without an auxiliary?
Robin won
Did Robin win?

The Inversion Lexical Rule

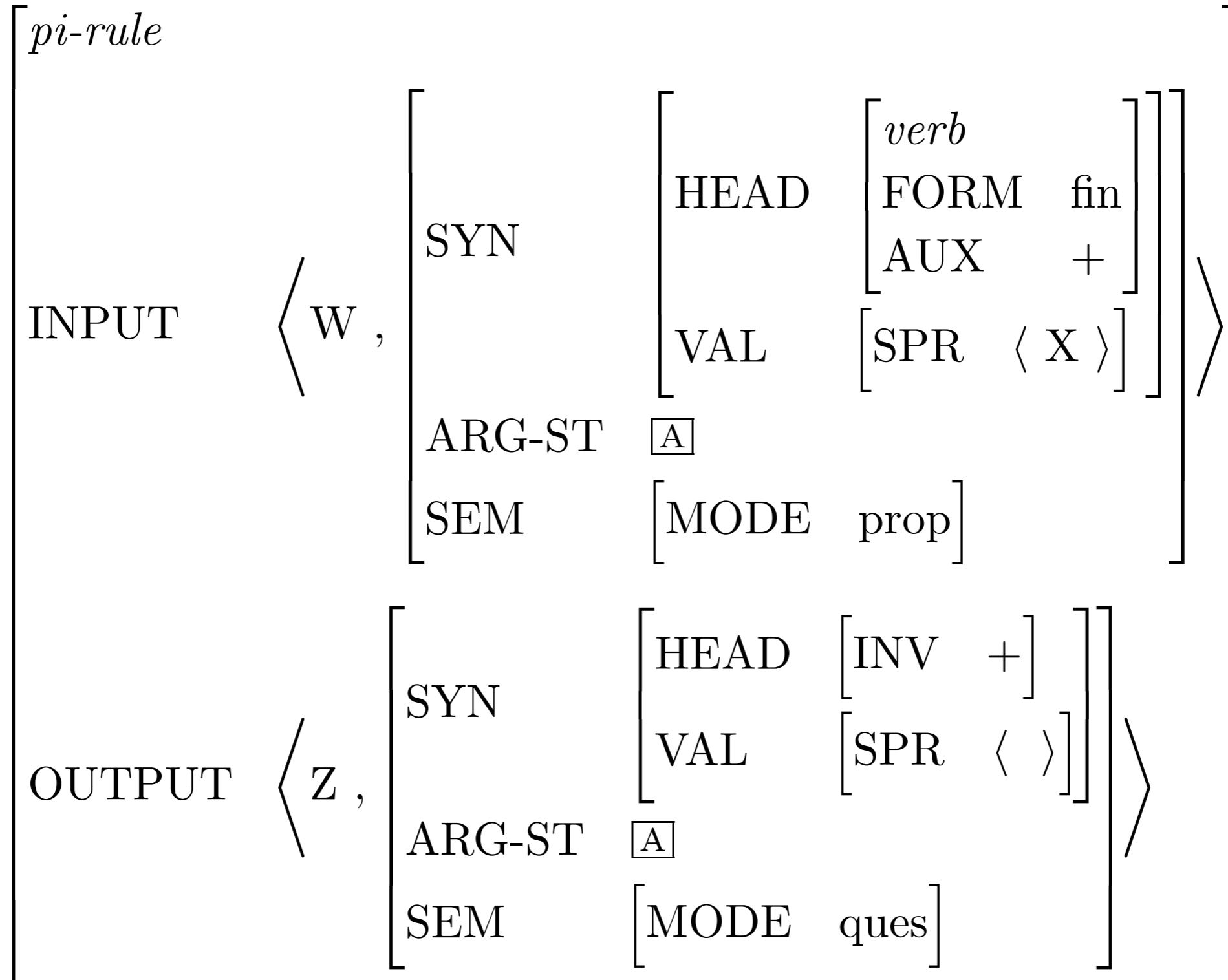

How the Rule Yields Inverted Order

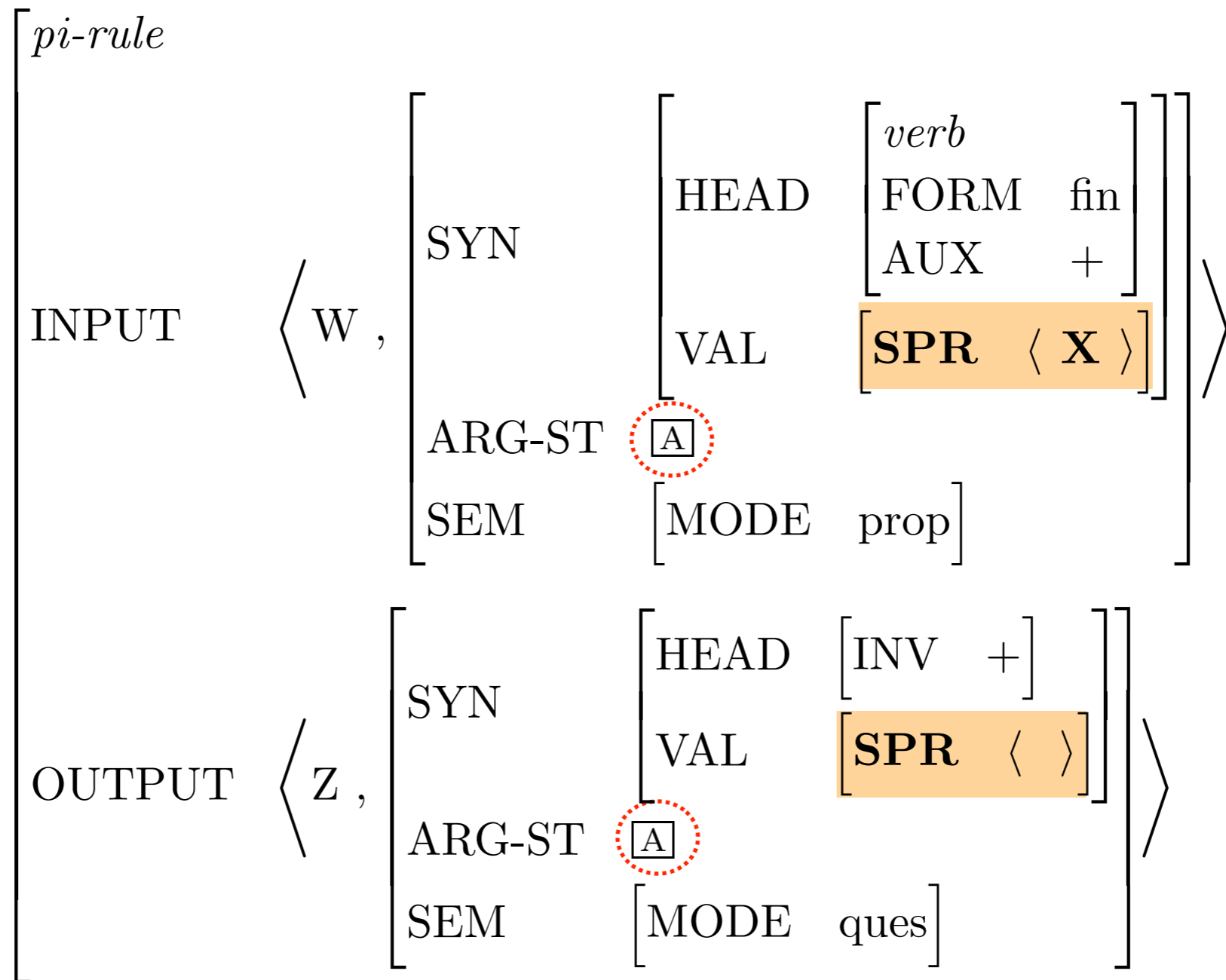

...plus the ARP

The Feature INV

- What is the INV value of inputs to the Inversion LR?
 - Perhaps surprisingly, the input is [INV +]
 - Word-to-word rules (*pi-rules*) have default identity of HEAD features, and no INV value is given on the input
- Then what work is the feature doing?
 - It's used to mark auxiliaries that can't or must be inverted
You better watch out vs. **Better you watch out*
I shall go (*shall* ~ 'will') vs. *Shall I go?* (*shall* ~ 'should')

Other Cases of Inversion

- Inversion is not limited to questions
 - Preposed negatives: *Never have I been so upset!*
 - Conditionals: *Had we known, we would have left.*
 - Exclamations: *May your teeth fall out!*
- Does our rule account for these?
 - No. Our rule's output says [MODE ques]. And each construction has slightly different idiosyncrasies.
- How might we extend our analysis to cover them?
 - Define a type of inversion lexical rules, sharing certain properties, but with some differences.

Inversion: A Sample Tree

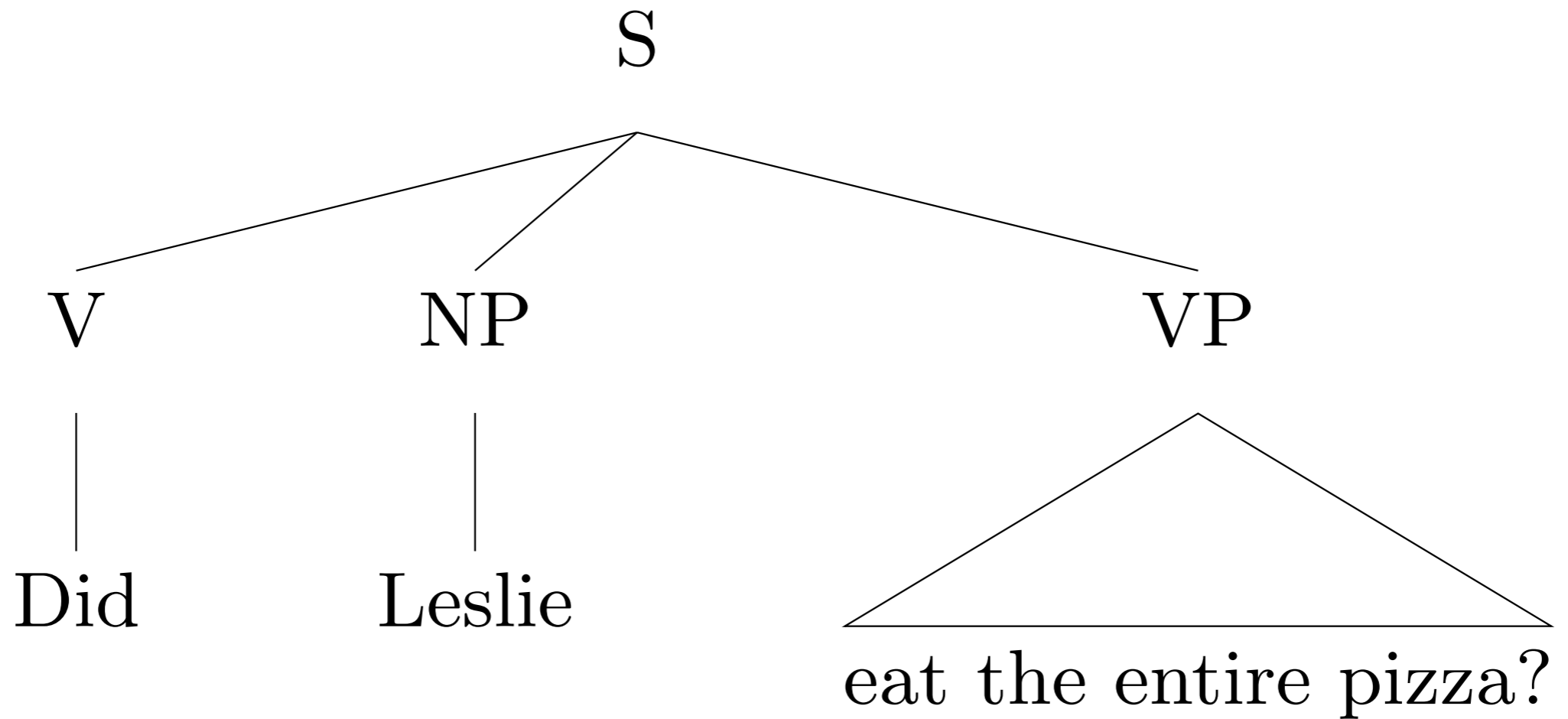

Contraction

- There are several types of contraction in English, but we're only talking about words ending in *n't*
- It may seem like just *not* said fast, but there's more to it
 - Only finite verbs can take *n't*:
**Terry must haven't seen us*
 - There are morphological irregularities:
won't, not **willn't* *%shan't*, not **shalln't*
mustn't pronounced *mussn't*
don't pronounced *doen't*, not *dewn't*
**amn't*

The Contraction Lexical Rule

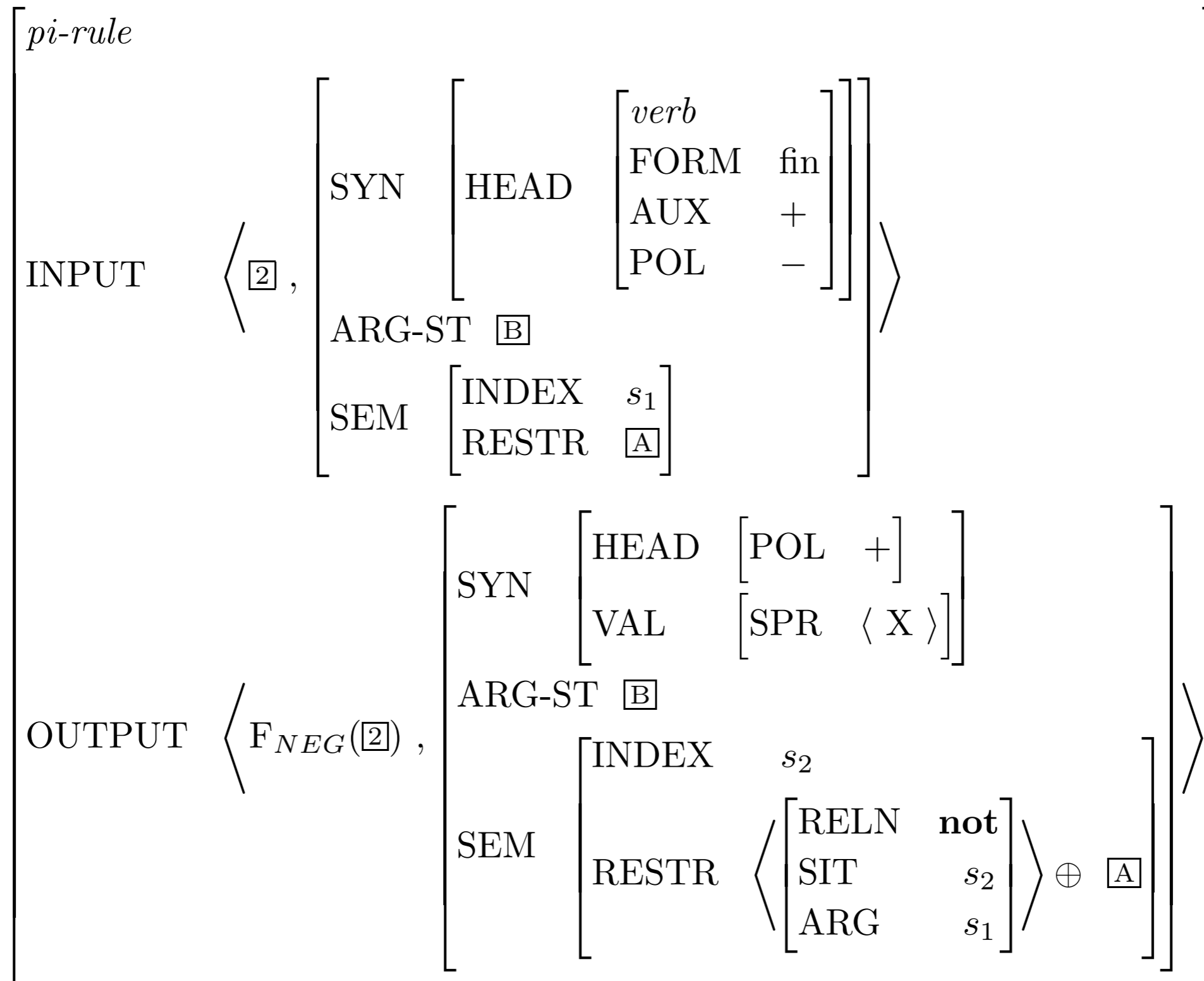

Most of the work is in the semantics

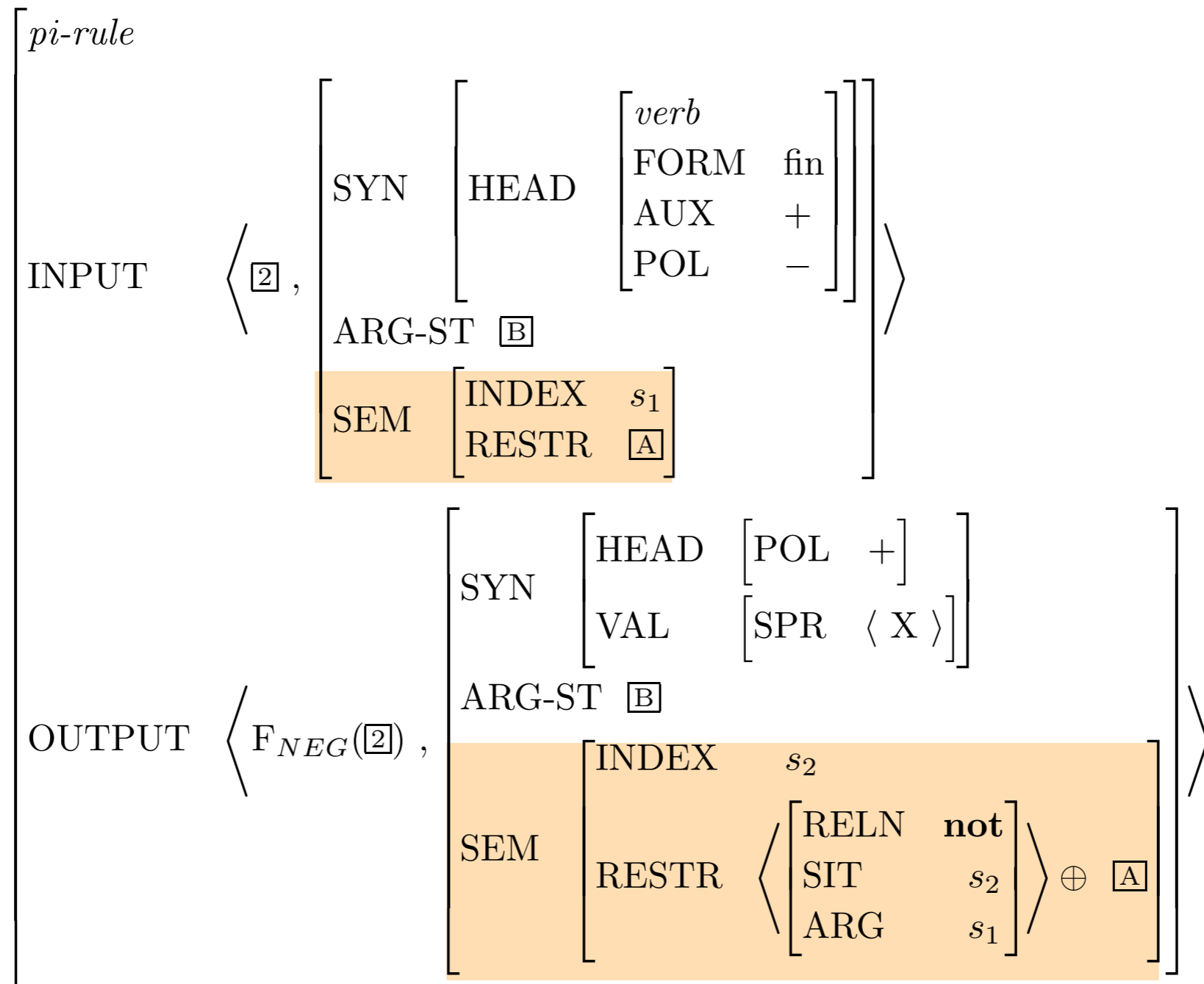

Why?

What does POL do?

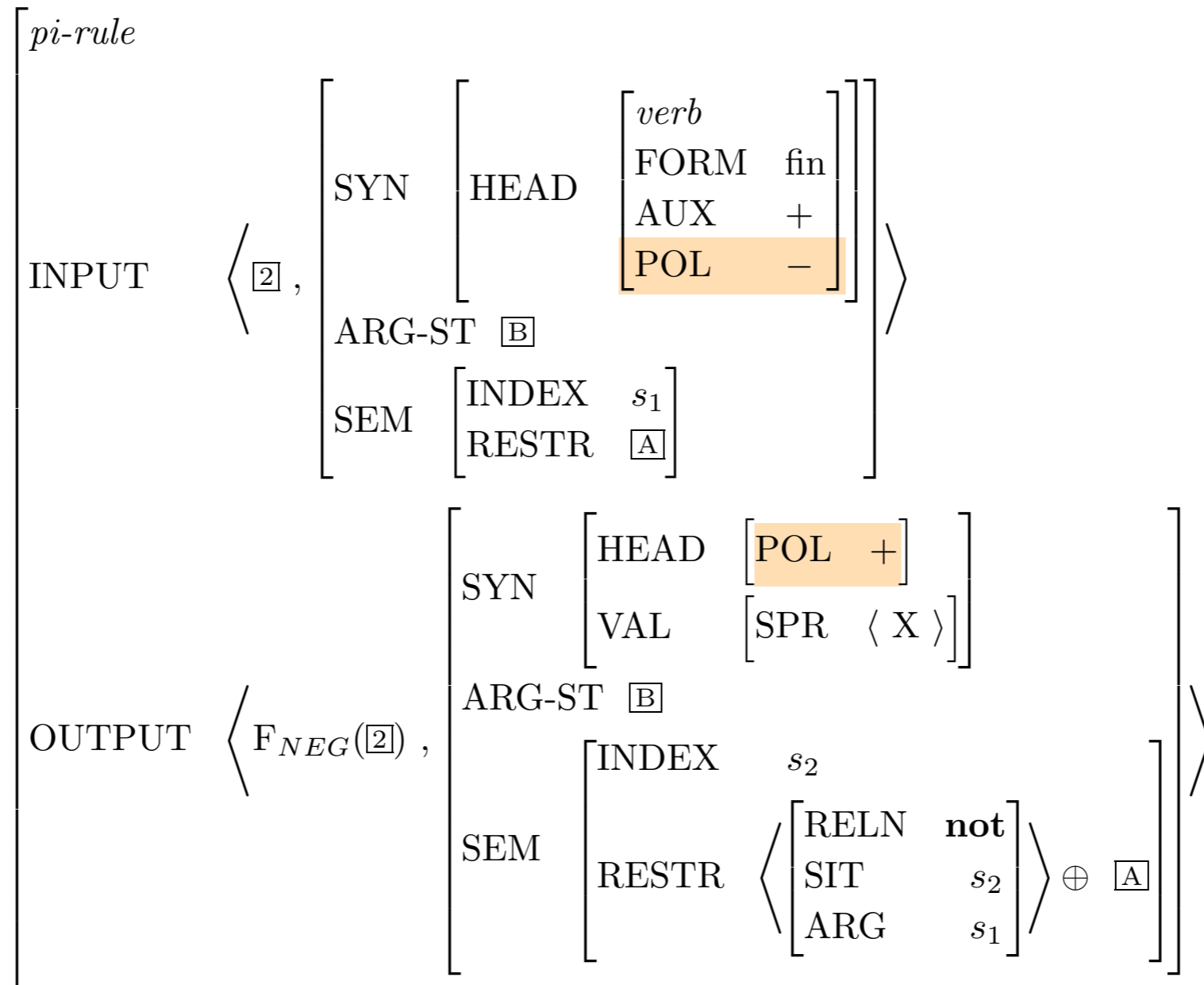

**We can't stop*

**They won't TOO mind*

Contraction: Sample Tree

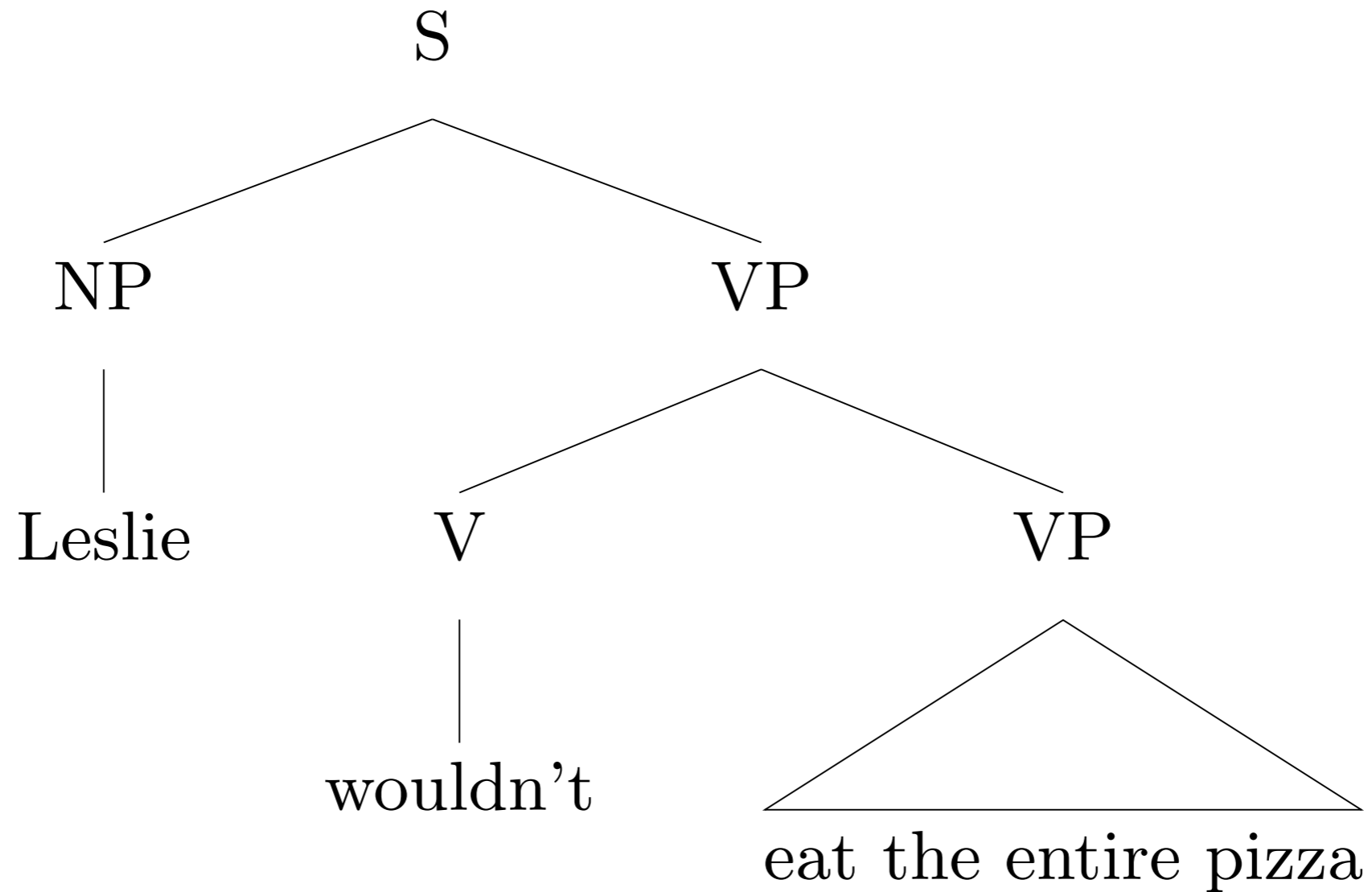

Ellipsis

- Ellipsis allows VPs to be omitted, so long as they would have been preceded by an auxiliary

* *Pat couldn't have been watching us, but
Chris*

- Unlike the other NICE properties, this holds of all auxiliaries, not just finite ones.
- What is the elliptical counterpart to a sentence with no auxiliary?

Whenever Pat watches TV, Chris watches TV
Whenever Pat watches TV, Chris does

The Ellipsis Lexical Rule

$$\left[\begin{array}{l}
 \text{INPUT} \\
 \text{OUTPUT}
 \end{array} \right. \left. \begin{array}{l}
 \left\langle \boxed{1}, \left[\begin{array}{l}
 \text{auxv-lxm} \\
 \text{ARG-ST} \langle \boxed{2} \rangle \oplus \boxed{A}
 \end{array} \right] \right\rangle \\
 \left\langle \boxed{1}, \left[\begin{array}{l}
 \text{dervv-lxm} \\
 \text{ARG-ST} \langle \boxed{2} \rangle
 \end{array} \right] \right\rangle
 \end{array} \right]$$

- Note that this is a derivational LR (*d-rule*) -- that is, lexeme-to-lexeme
- This means that SYN and SEM are unchanged, by default

Ellipsis: A Sample Output

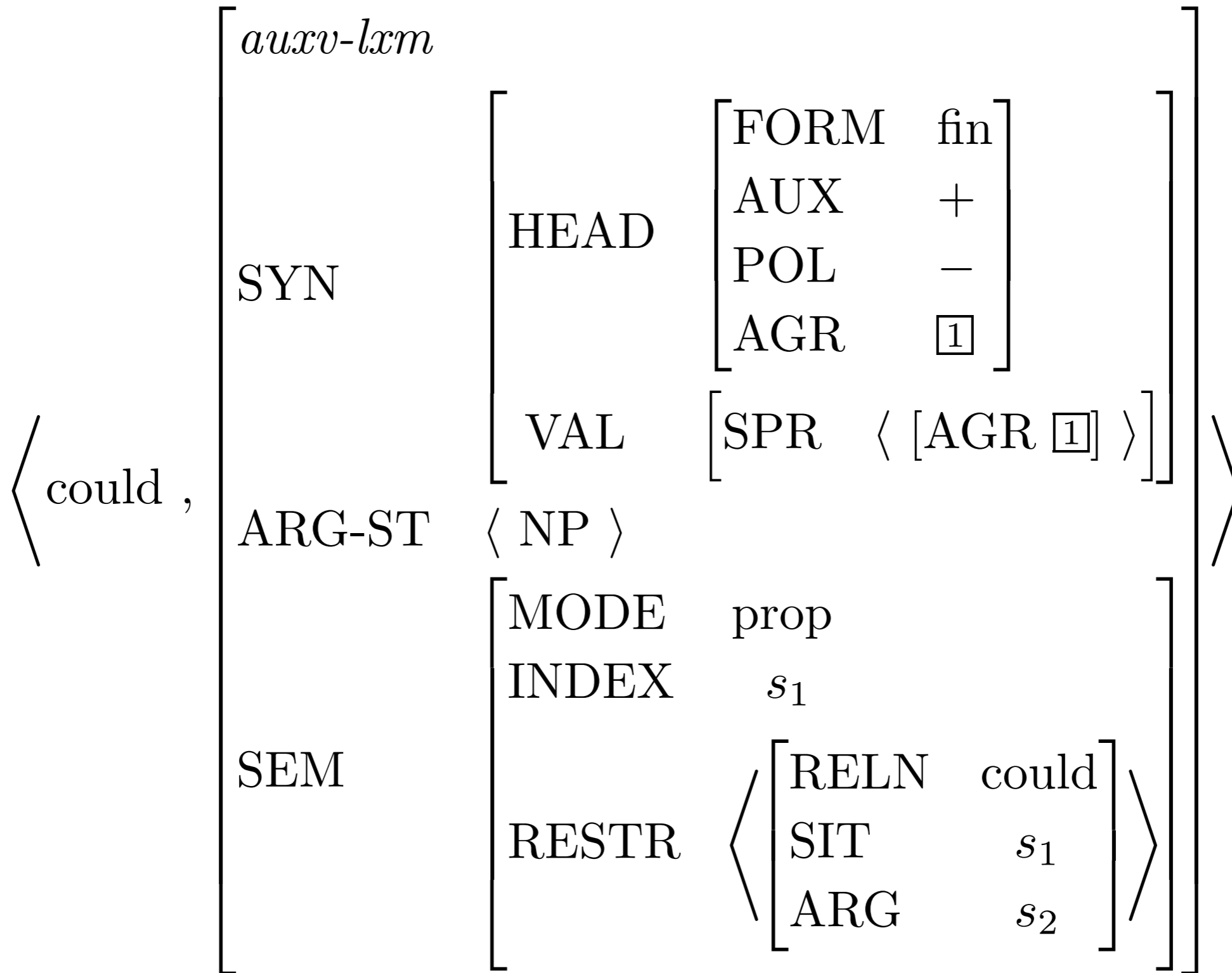

Ellipsis: A Sample Tree

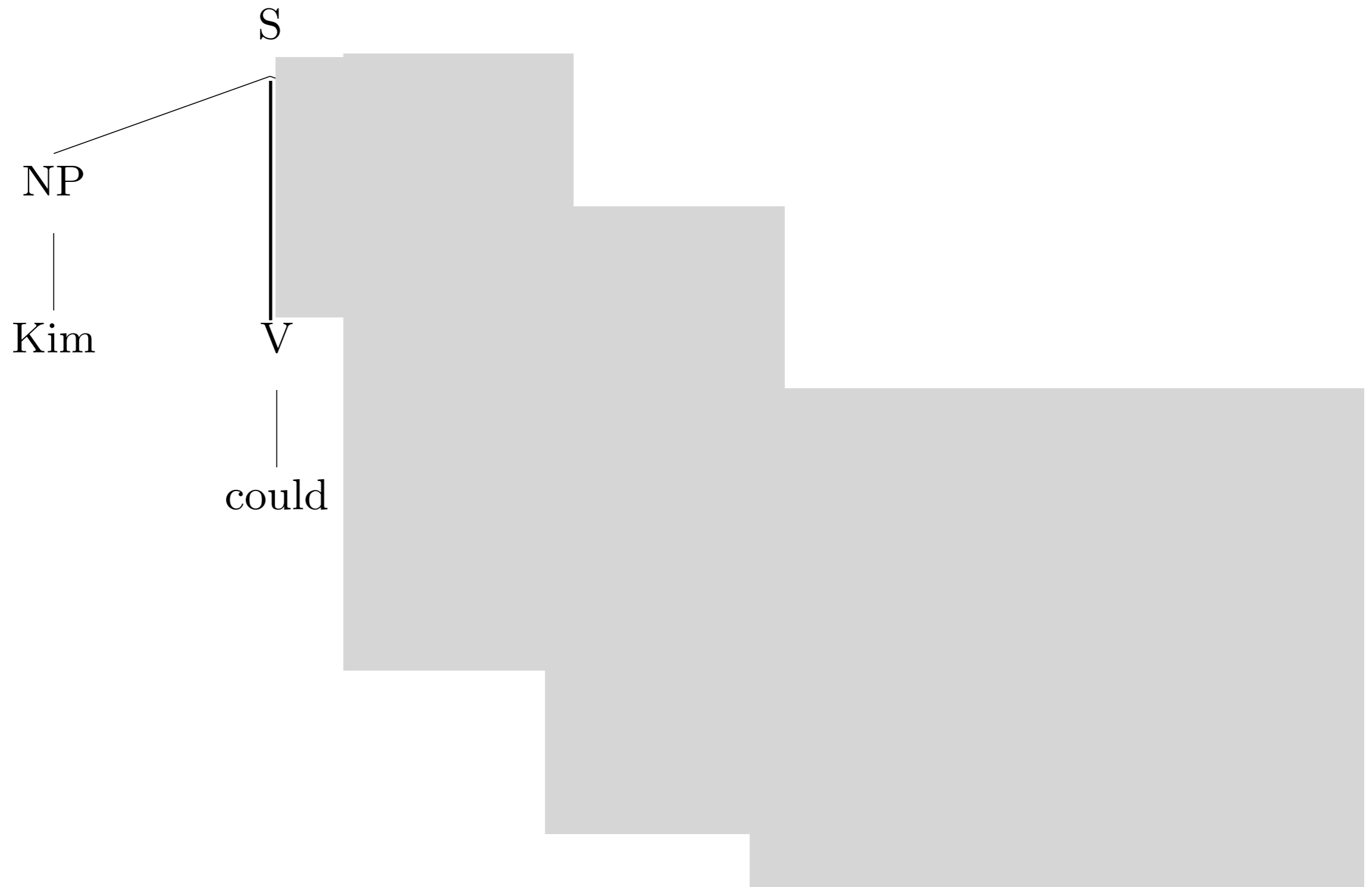

Semantics of Ellipsis

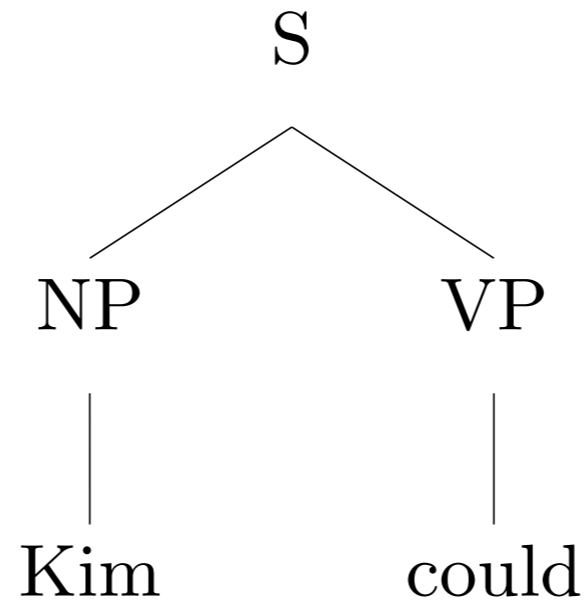

What is the SEM value of the S node of this tree?

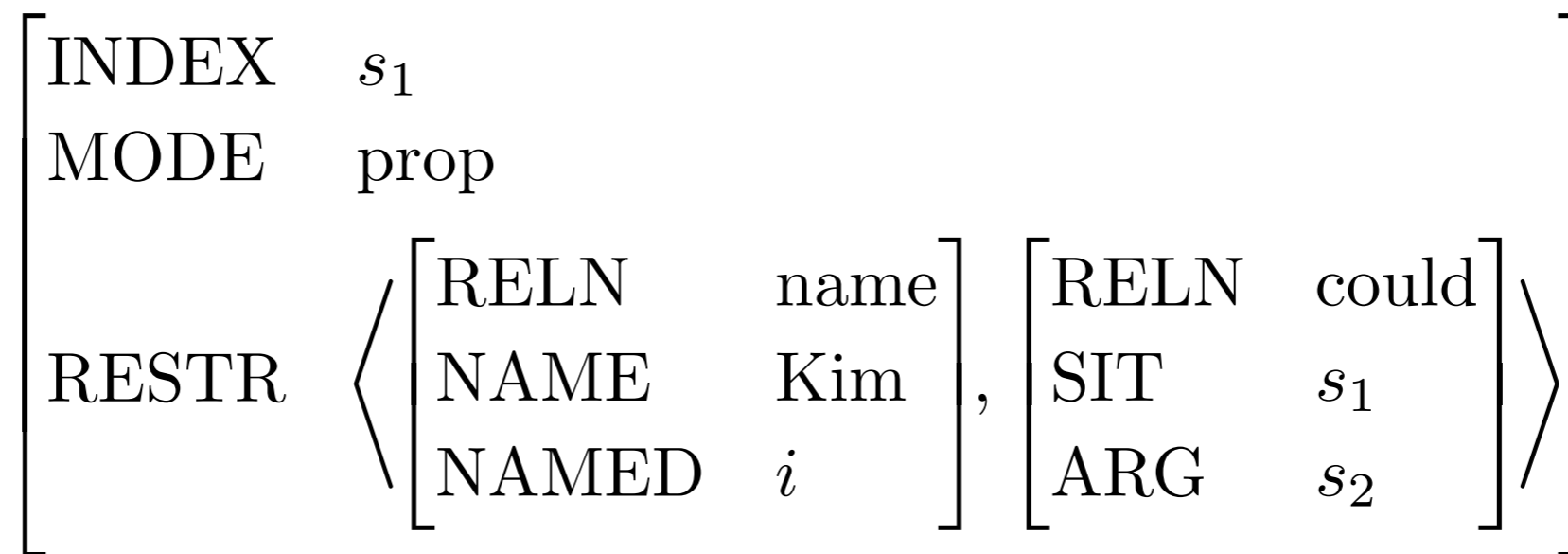

Note: s_2 has to be filled in by context.

Infinitival *to* Revisited

- VP Ellipsis can occur after *to*:

We didn't find the solution, but we tried to.

- This is covered by our Ellipsis LR if we say *to* is [AUX +].
- Since AUX is declared on type *verb*, it follows that *to* is a verb.

do Revisited

- Chomsky's old analysis: in sentences w/o auxiliaries...
 - Tense can get separated from the verb in various ways
 - Negation/Reaffirmation inserts something between Tense and the following verb
 - Inversion moves Tense to the left of the subject NP
 - Ellipsis deletes what follows Tense
 - When this happens, *do* is inserted to support Tense
- Our counterpart:
 - NICE properties hold only of auxiliaries
 - *do* is a semantically empty auxiliary, so negated, reaffirmed, inverted, and elliptical sentences that are the semantic counterparts to sentences w/o auxiliaries are ones with *do*.

Summary

- Our analysis employs straightforward mechanisms
 - Lexical entries for auxiliaries
 - 3 new features (AUX, POL, INV)
 - 4 lexical rules
- We handle a complex array of facts
 - co-occurrence restrictions (ordering & iteration)
 - the NICE properties
 - auxiliary *do*
 - combinations of NICE constructions

Overview

- Brief review of our analysis so far
- NICE properties of auxiliaries
- The auxiliary *do*
- NICE properties (lexical rules)
- Reading questions

But first

- Midterms returned
- Questions from Woodley's treehouse presentation?

Reading Questions

- Constituent negation (Not many arrows hit the target) is not covered in this analysis--the footnote mentioned additional machinery would be required. What might some of this machinery be?
- I'm confused about the different versions of "not" discussed in the chapter. It's discussed that the version of "not" we're looking into negates the whole sentence, not just the VP. However, our lexical rule only applies to the verb, making it seem like it does just that- negates just the VP and not the whole sentence. How does the other "not" negate just the VP?

Reading Questions

- (39) a. Not many arrows hit the target.
b. I try not to make trouble.
c. Pat must have not been listening.

Reading Questions

- Why are the examples in 39 not be viewed as sentence negation, particularly for b and c where not is modifying a verb? I understand that maybe syntactically not is not applied to the whole sentence, but it seems to be like semantically it is.
- However, it appears to me that both (a) and (c) could be interpreted as sentential negations. Not many arrows hit the target sound semantically identical to It is not the case that many arrows hit the target; likewise, Pat must have not been listening could easily mean It is not the case that Pat must have been listening (although I'm assuming that the author may have intended it to mean Pat must have actively been trying not to listen).

Reading Questions

- In Chapter 13, we discuss sentence negation but leave constituent negation alone. Are there ways to automatically differentiate between types of negation? What is the current research in this?

Reading Questions

- How come we're using lexical rules instead of grammatical rules, for instance with the ADV_{pol}-Addition Lexical Rule?
- The ADV_{pol}-Addition Lexical Rule takes a [POL -] auxiliary verb, makes it [POL +], and inserts an ADV_{pol} argument in the second place of its ARG-ST list. I get why its doing this, but I'm wondering about how this works in implementation. Specifically, what is the benefit of having this as a post-inflectional rule rather than having the ADV_{pol} argument be optional, and not having to indicate POL +/-?

The ADV_{pol} -Addition Lexical Rule

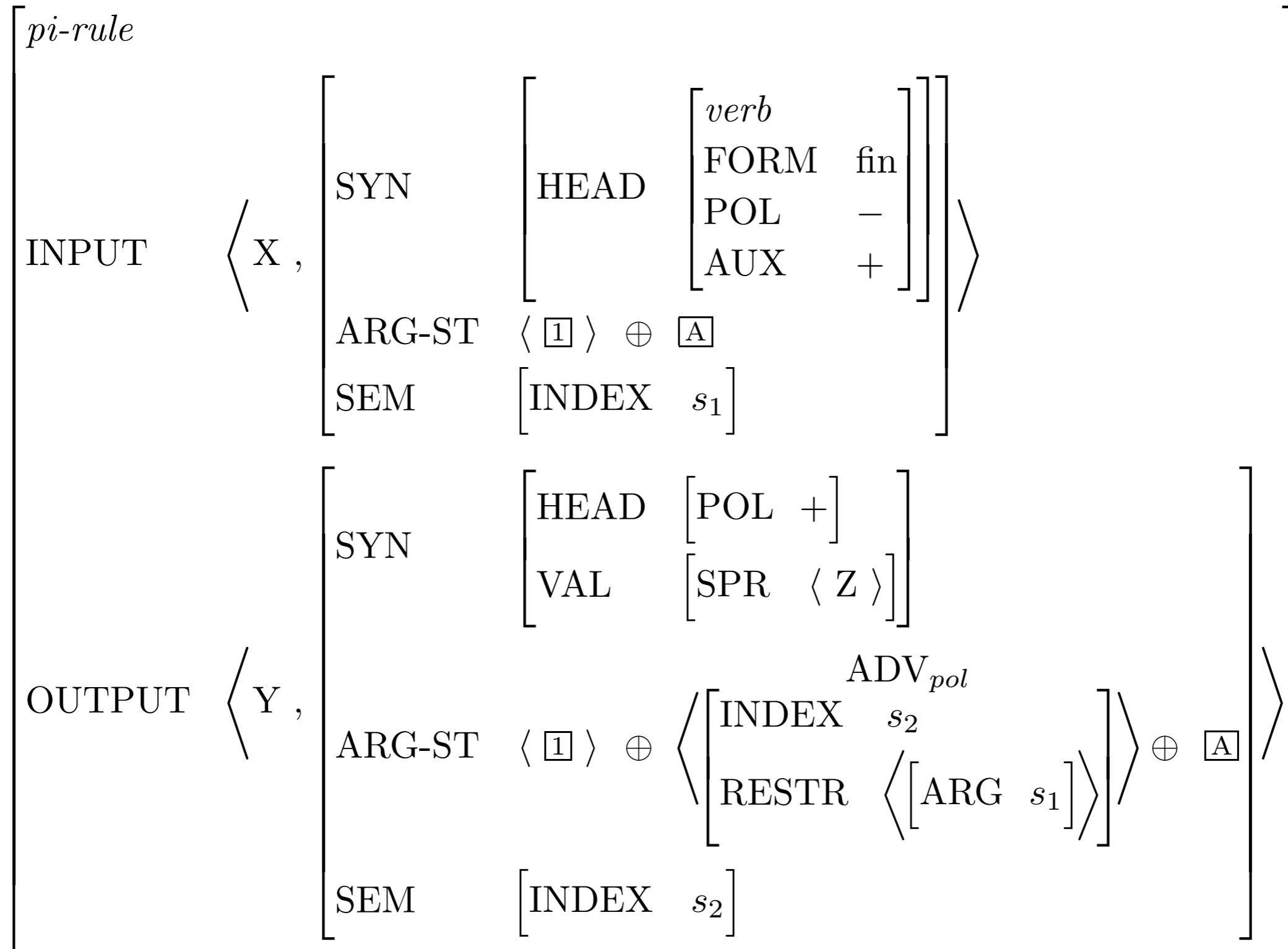

Reading Questions

- There are cases in which (42a) and (42d) are valid.
- (a) In Sandy did so so write that, if the first so is sentential and the second is constituent, can mean, It indeed is the case that Sandy wrote that in such a manner.
- (b) With Leslie can too so lift that - this could mean It is indeed the case that Leslie can lift that in such a manner.
- The dialect of English with which I am familiar does allow the iteration of the reaffirming polarizing adverbs SO and TOO, but only in one case: 42b, Sandy did so too write that. How could the grammar account for this one exception while excluding other cases of adverb iteration?

Reading Questions

- (42) a. *Sandy did so so write that.
b. *Sandy did so TOO write that.
c. *Leslie can TOO TOO lift that.
d. *Leslie can TOO so lift that.

Reading Questions

- On another note, how common are POL+ adverbs like "so" and "too" (in "Sandy did SO write that.") in other languages? Is this something we see a lot or is this an observation about English?

Reading Questions

- What is the motivation behind making the negation predication the 'highest' predication in a sentence (by making not's INDEX the INDEX of the whole sentence)? The book merely states that this is "the correct semantic result" (409) without going into detail about why. Is there some reason we would need the negation/reaffirmation's INDEX to be visible to other constituents if the sentence is embedded in a larger phrase?

Reading Questions

- I have read the description on page 412 of how the SHAC is maintained for the Inversion Lexical Rule despite the problems for be, have, and do created by its moving the SPR into COMPS several times. I must be missing something.
- I'm confused how the SHAC interacts with inversion. The OUTPUT for the Inversion Lexical Rule is of type word, so it doesn't inherit the SHAC constraint. But these inverted verbs are still (indirectly) constrained by the SHAC because they must combine with other lexemes constrained by the SHAC. Am I understanding this correctly?

Reading Questions

- In the Inversion LR (pg.59) why there is no mention of the SPR value in the input?
- It's not clear to me why specifying a lexical entry as [INV -] bars it from undergoing the Inversion Lexical Rule. The fact that the OUTPUT is [INV -] is certainly redundant, but it doesn't contradict the INPUT specification, does it? Is it assumed that anything mention in the OUTPUT that isn't in the INPUT is the opposite value?

The Inversion Lexical Rule

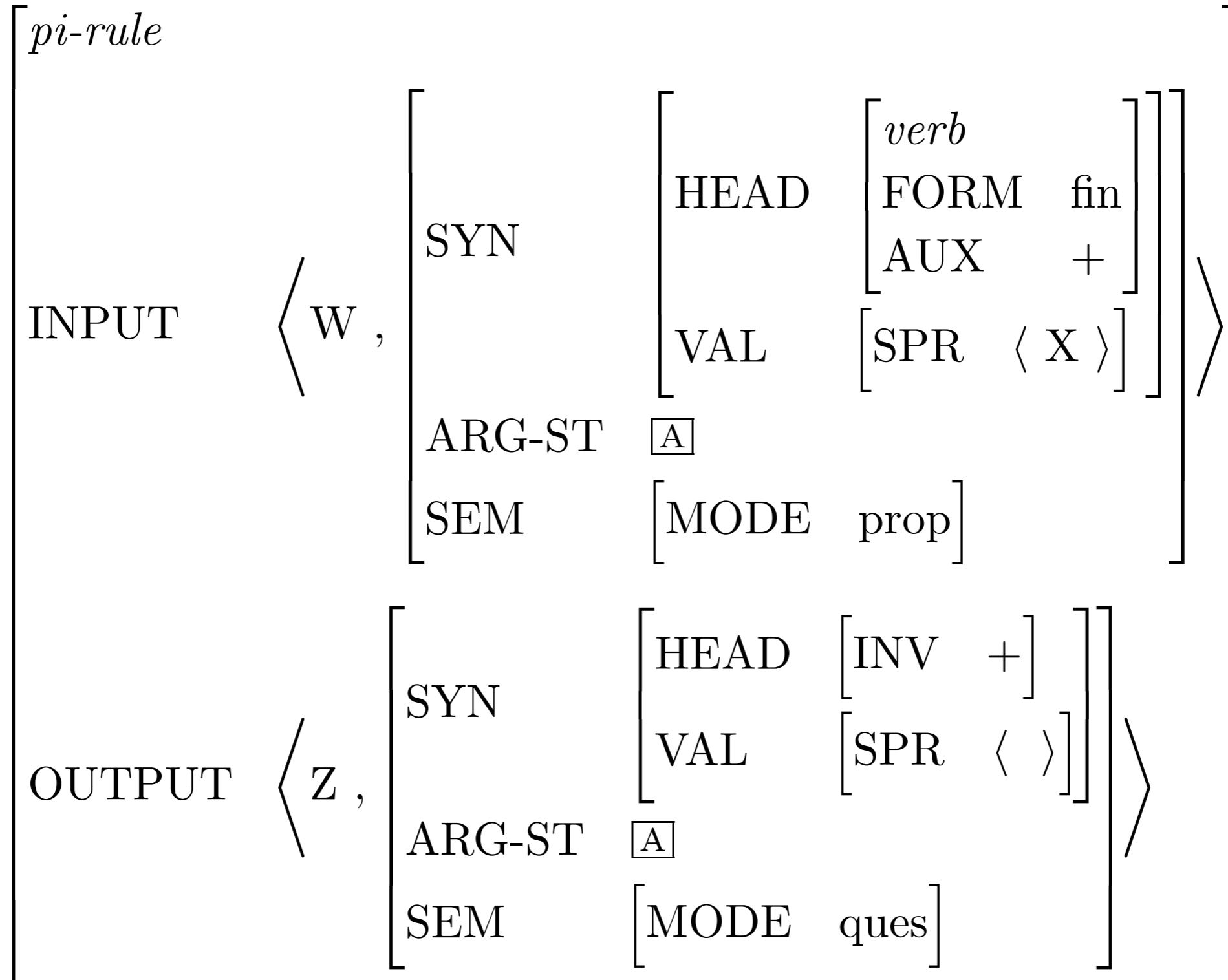

Reading Questions

Speaker A: Could that woodchuck have chucked all that wood?

Speaker B: *It could. / It could have.

Speaker A: Could the New Year's Sherlock special be better than Series 1?

Speaker B: It could.

- How might we account for these distributions, or is this just outside the scope of what we are trying to accomplish?

Reading Questions

- How does the Ellipsis Lexical Rule account for a sequence of auxiliary verbs, such as "They have to?" The book mentions treating the infinitival to as an auxiliary verb, but I'm still unsure how multiple auxiliary verbs would factor into the OUTPUT value.
- I can't figure out the answer to Exercise 4. Why do we need the type `dervv-lxm` for the Ellipsis Lexical Rule? Why can't the outputs be `auxv-xm`?

The Ellipsis Lexical Rule

$$\left[\begin{array}{l} d\text{-rule} \\ \text{INPUT} \left\langle \boxed{1}, \left[\begin{array}{l} \text{auxv-lxm} \\ \text{ARG-ST} \langle \boxed{2} \rangle \oplus \boxed{A} \end{array} \right] \right\rangle \\ \text{OUTPUT} \left\langle \boxed{1}, \left[\begin{array}{l} \text{dervv-lxm} \\ \text{ARG-ST} \langle \boxed{2} \rangle \end{array} \right] \right\rangle \end{array} \right]$$

Reading Questions

- This chapter introduces a rule for inversion with auxiliaries that licenses questions such as "Can Pat tap-dance?" which has a corresponding non-inverted sentence "Pat can tap-dance." But how will we get the "do" to allow sentences like "Does Pat like tap-dancing" whose corresponding form would be "Pat likes tap-dancing?" which does not have an auxiliary?

Reading Questions

- How could our analysis for ellipsis account for auxiliary verbs followed by polarized adverbs eg. "have not", "have so", "have too"?
- Since the output of the Contraction Lexical Rule has a nonempty SPR list and the Inversion Lexical Rule's output has an empty SPR, it seems like we would have to undergo the Contraction Lexical Rule before the Inversion Lexical Rule to get something like "Can't Pat tap-dance?" Is there a particular reason we wouldn't want to invert first and then have negation? Or is this just an unimportant consequence of the lexical rules?

Reading Questions

- These questions are partly inspired by the reading and partly inspired by the lecture last Thursday where we talked about some other, less traditional AUX elements of English, like *better*, and I was wondering how many of the NICE properties a verb-*y* element would have to have before it is classified as an auxiliary? Is there one particular feature that if missing, makes assigning a verb to AUX more counterintuitive or, at least, more inconvenient with respect to our theory? Also, are there additional features special to AUX that aren't nice? And, finally, Is there any additional structuring within the *auxv-lxm* that handles the distribution of these features, or is it handled on a case by case basis via feature specifications in the individual lexical entries?