

Giant Lantern

Night Market Furnitures Installation Guide

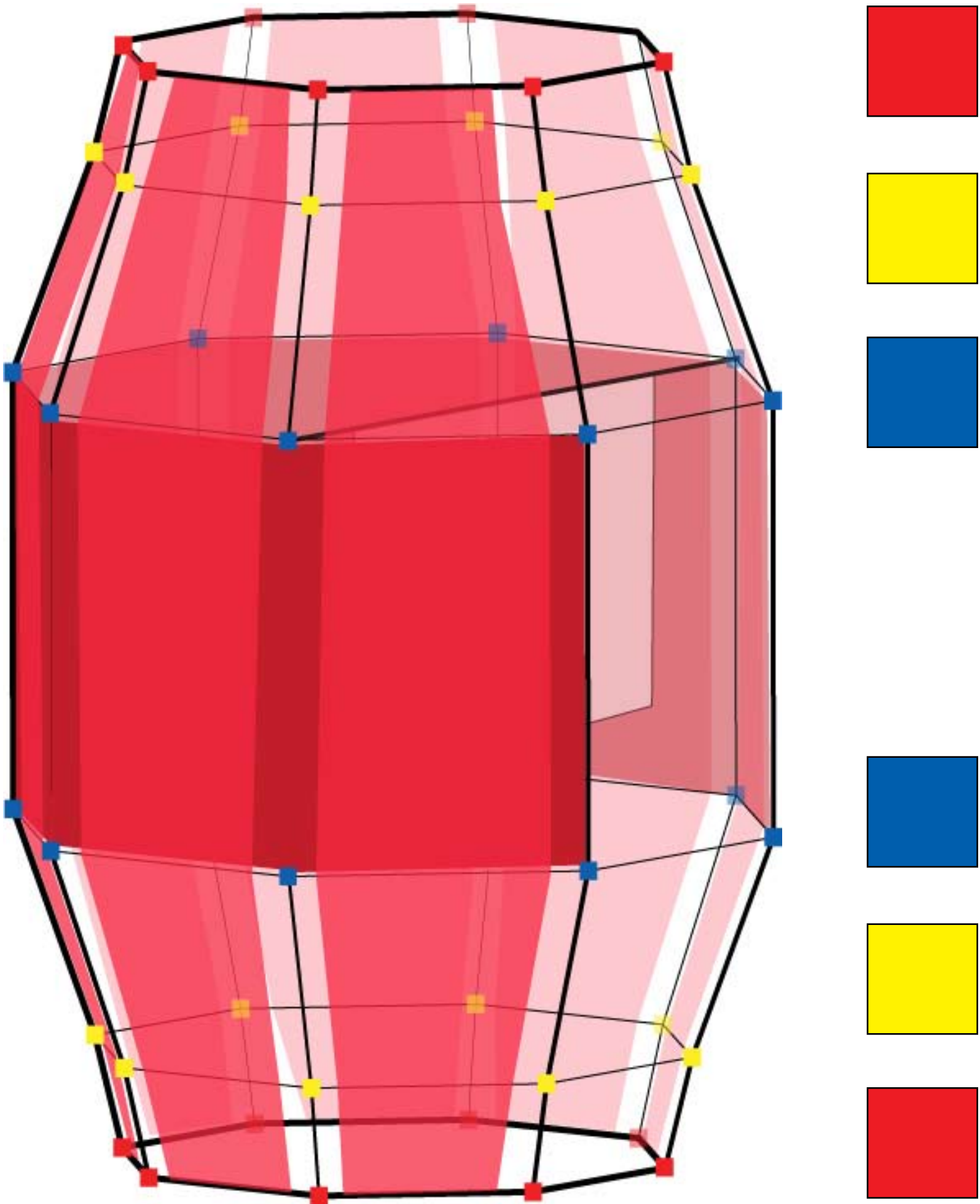

Design Concept:

Giant lanterns traditionally appear at important festivals to bring light and color and to draw attention to the event. The giant lantern in this design fuses the traditional with the contemporary by bringing in the youth group's storytelling element through video media.

A collaborative project of Cultural Landscape Studio (Department of Landscape Architecture, University of Washington) and WILD Youth Program (International District Housing Alliance). Instructor: Jeff Hou; Youth Facilitators: Guihui Yuan, Carmen Cruz; WILD Program: Joyce Pisanont, Alan Lee, Amalia Gonzalez-Kahn. Autumn 2006. Design Team: Emily Carlson, Ron Rovetto, Janette Ebey, Luan Quach, Vick Mai, Binh Tien

red and yellow vertical fittings



(16)



yellow horizontal fittings

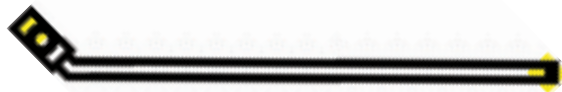

(16)

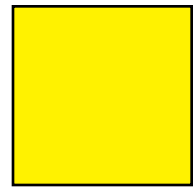

blue fittings vertical



(16)



horizontal

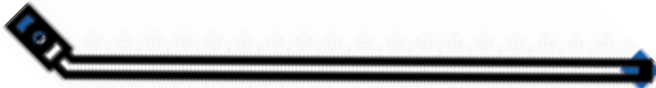

blue and yellow vertical fittings



(16)

projector stand and movie screen

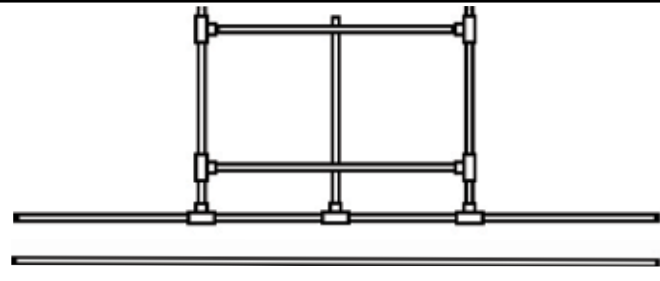

(1 each)



mesh panel weights



(8)

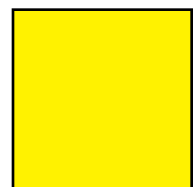

Pieces are color-coded. Corresponding color pieces go together. Just match the colors for easy assembly.

blue fittings
attached



Attach blue
vertical pieces
in corresponding
numbers to blue
horizontal pieces.

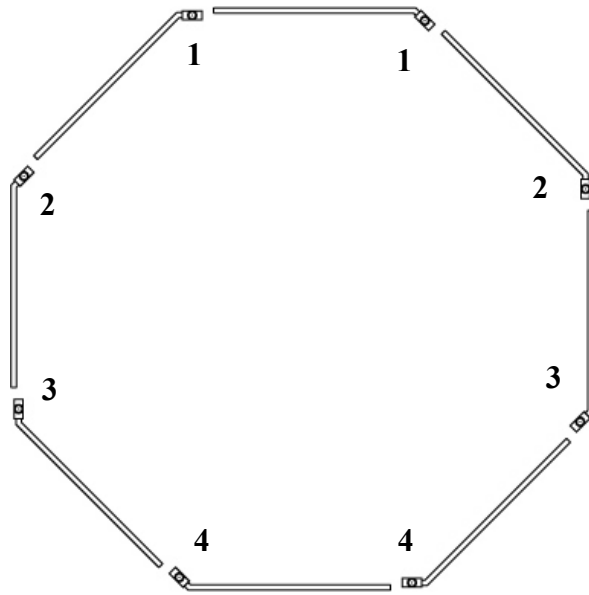

blue vertical
pieces 1-4.

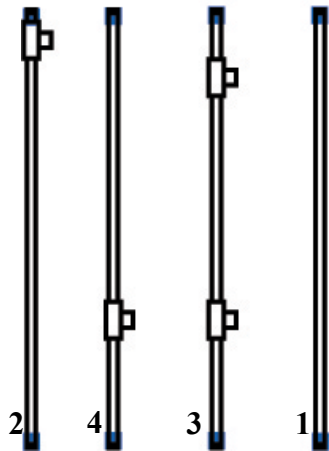

blue horizontal
pieces.

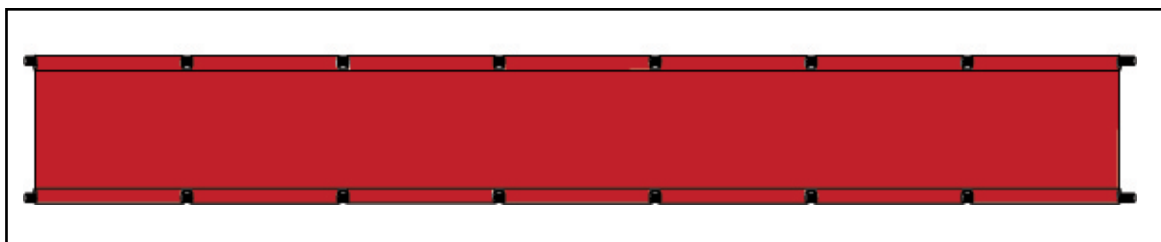
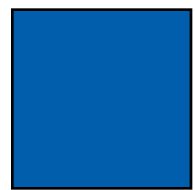
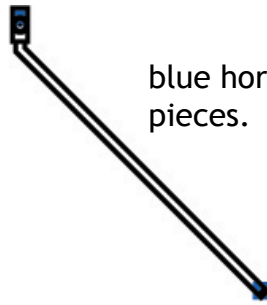

Attach burlap fabric piece to frame after assembling blue section. Slide fabric loop over horizontal pieces until fabric is completely attached.

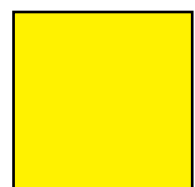
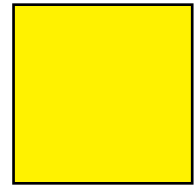
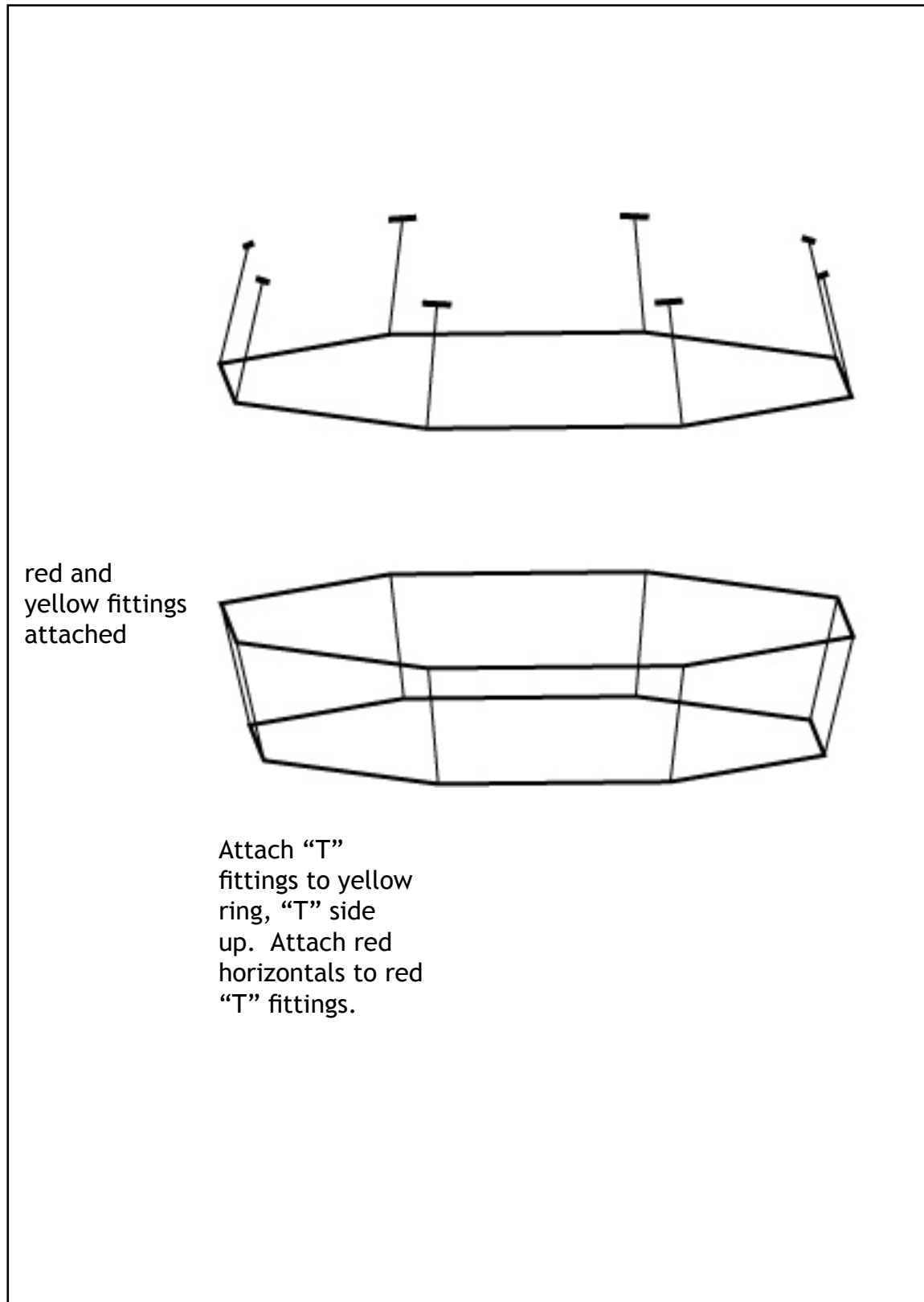

Build the yellow ring first. Attach mesh panels to red horizontal poles before connecting the red ring to the yellow ring. The mesh panels are hung vertically from the top. Mesh panel weights (PVC pieces) are inserted in the bottom loop of fabric. The bottom of the mesh panels with PVC inserts are wrapped beneath the bottom ring after the lantern is completed.

Assemble yellow and red ring and attach to the top of the blue ring with yellow and blue vertical poles. Assemble the second yellow and red ring inside the blue ring.

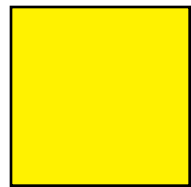
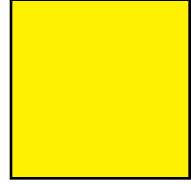
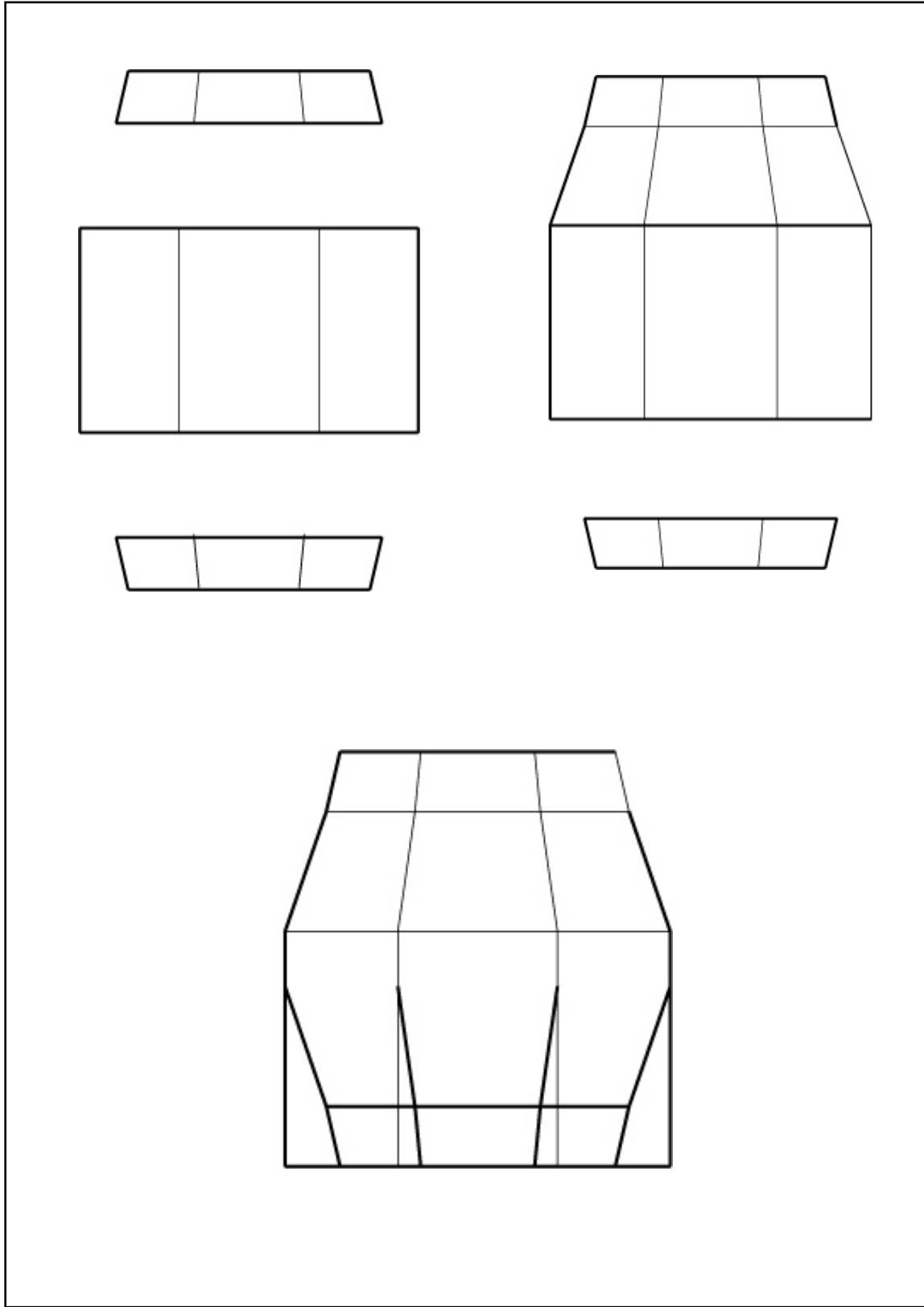

String lights from top to bottom along each vertical element of the lantern and attach to poles with connectors.

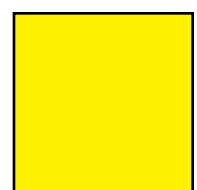
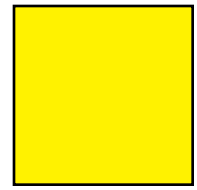
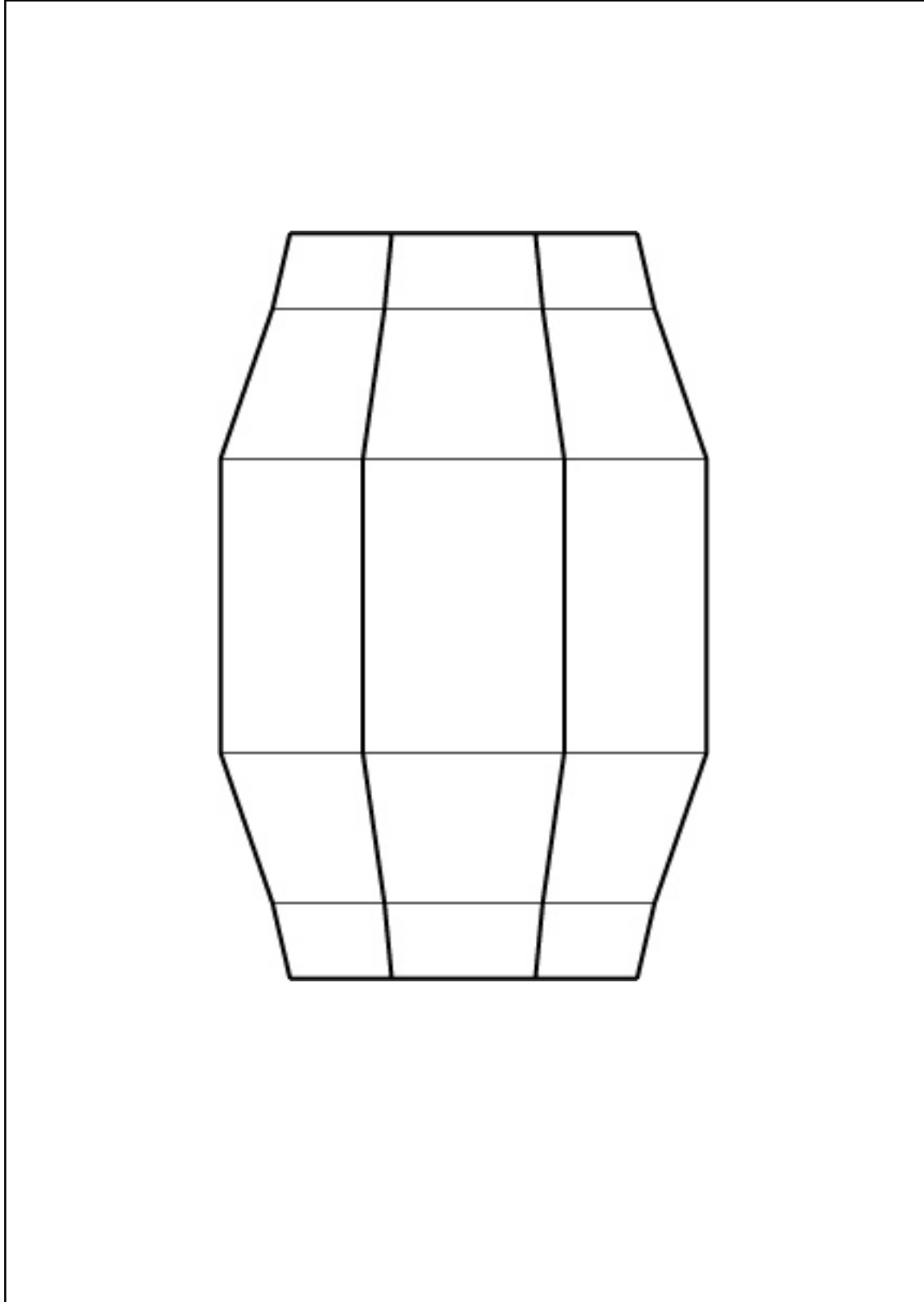

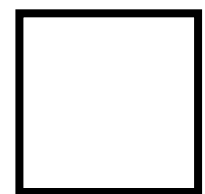
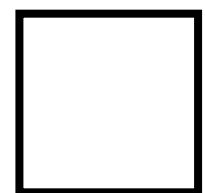
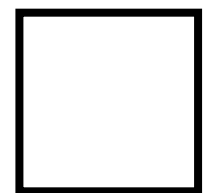
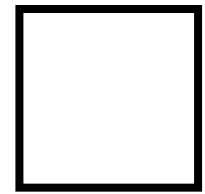
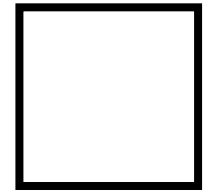
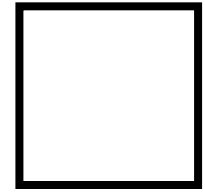
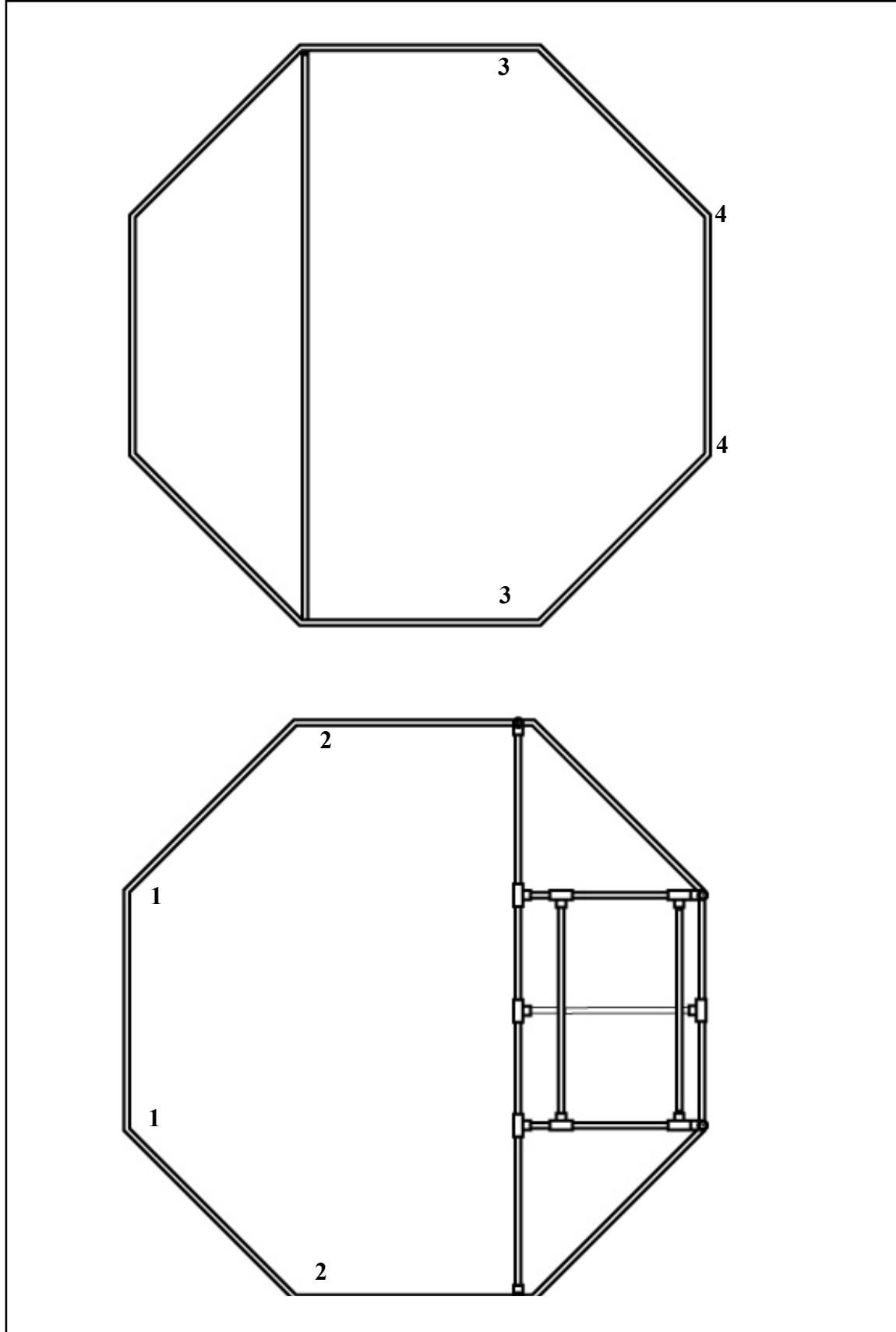

Attach movie screen and projector stand to blue vertical poles.
Make sure the playback equipment isn't set to a sleep function,
and set the film to loop. These parts do not have color coding.