

TOSHIBA MOS MEMORY PRODUCTS

1024 WORD x 4 BIT STATIC RAM

TMM2114AP-12
TMM2114AP-15

DESCRIPTION

The TMM2114AP is a 4,096 bits static random access memory organized as 1024 words by 4 bits and operates from a single 5V power supply. Toshiba's high performance device technology provides both high speed and low power features with maximum operating current of 60mA and maximum access time of 120ns/150ns. The memories with 6Tr. cells are fully static in operation and require no clocks or refresh periods. Therefore the TMM2114AP is most

suitable for use in microcomputer peripheral memory where high performance, lower cost, simple interfacing are required.

The TMM2114AP is fabricated with N channel silicon gate depletion load type MOS technology by ion implantation for high speed, high performance and high reliability.

The chip is moulded in the standard 18 pin plastic package with 0.3 inch width.

FEATURES

- 1024 Word x 4 Bit organization
- Fully static operation
- Single 5V supply voltage
- All inputs and outputs: Directly TTL compatible
- Three state output: Wired OR capability
- Common data inputs and outputs

- 2114A type pin compatible
- Fast Access time and Low Operating Current (Max.)

	TMM2114AP-12	TMM2114AP-15
$t_{ACC}(ns)$	120	150
$I_{CC}(mA)$	60	60

- Input protected: All inputs have protection against static charge.

PIN CONNECTION (TOP VIEW)

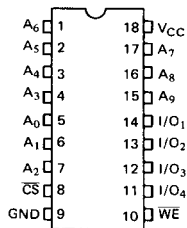

PIN NAMES

$A_0 \sim A_3$	Column Address Inputs
$A_4 \sim A_9$	Row Address Inputs
$I/O_1 \sim I/O_4$	Data Input/Output
\overline{CS}	Chip Select Input
\overline{WE}	Write Enable Input
V_{CC}	Supply Voltage
GND	Ground

BLOCK DIAGRAM

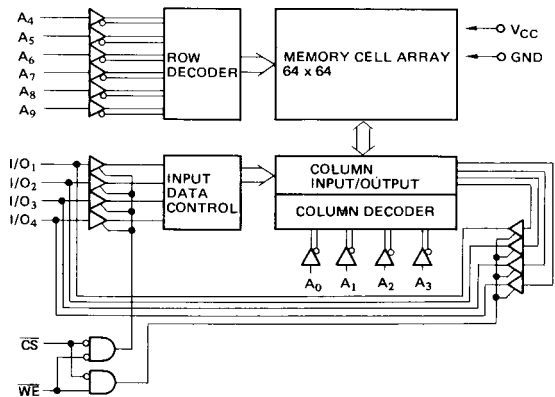

TRUTH TABLE

CS	WE	D _{IN}	D _{OUT}	MODE
H	*	*	High Impedance	Non-decode
L	H	*	Data Output	Read
L	L	H/L	Data Input	Write

* L or H

MAXIMUM RATINGS

SYMBOL	ITEM	RATING	UNIT
V _{CC}	Supply Voltage	-0.5 ~ 7.0	V
V _{I/O}	Input/Output Voltage	-0.5 ~ 7.0	V
T _{OPR}	Operating Temperature	0 ~ 70	°C
T _{STG}	Storage Temperature	-55 ~ 150	°C
T _{SOLDER}	Soldering Temperature • Time	260 • 10	°C • sec
P _D	Power Dissipation (T _a = 70°C)	850	mW

DC RECOMMENDED OPERATING CONDITIONS

SYMBOL	PARAMETER	MIN.	TYP.	MAX.	UNIT
V _{IH}	Input High Voltage	2.0	—	V _{CC} +1.0	V
V _{IL}	Input Low Voltage	-0.5	—	0.8	V
V _{CC}	Supply Voltage	4.5	5	5.5	V

DC CHARACTERISTICS (T_a = 0 ~ 70°C)

SYMBOL	PARAMETER	CONDITIONS	MIN.	TYP.*	MAX.	UNIT
I _{IL}	Input Leakage Current	V _{IN} = 0V ~ 5.5V	-10	—	10	μA
V _{OH}	Output High Voltage	I _{SOURCE} = -1.0mA	2.4	—	—	V
V _{OL}	Output Low Voltage	I _{SINK} = 2.1mA	—	—	0.4	V
I _{LO}	Output Leakage Current	CS = V _{IH} or WE = V _{IL} V _{OUT} = 0.0V ~ 5.5V	-10	—	10	μA
I _{CC}	Supply Current	I _{OUT} = 0mA	—	—	60	mA

* T_a = 25°C, V_{CC} = 5V

AC CHARACTERISTICS (Ta = 0 ~ 70°C, VCC = 5V ± 10%, 1-TTL Gate & CL = 100pF, tr, tf ≤ 10 ns)

READ CYCLE

SYMBOL	PARAMETER	TMM2114AP-12			TMM2114AP-15			UNIT
		MIN.	TYP.*	MAX.	MIN.	TYP.*	MAX.	
t _{RC}	Read Cycle Time	120	—	—	150	—	—	ns
t _{ACC}	Access Time	—	—	120	—	—	150	ns
t _{CO}	Chip Select Time	—	—	70	—	—	70	ns
t _{CX}	Output Active from CS	10	—	—	10	—	—	ns
t _{OD}	Deselect Time	0	—	35	0	—	40	ns
t _{OH}	Output Hold From Address Change	20	—	—	20	—	—	ns

* Ta = 25°C, VCC = 5V

WRITE CYCLE

SYMBOL	PARAMETER	TMM2114AP-12			TMM2114AP-15			UNIT
		MIN.	TYP.*	MAX.	MIN.	TYP.*	MAX.	
t _{WC}	Write Cycle Time	120	—	—	150	—	—	ns
t _{WP}	Write Pulse Width	70	—	—	90	—	—	ns
t _{WR}	Write Recovery Time	0	—	—	0	—	—	ns
t _{ODW}	Output High Z From \overline{WE}	0	—	35	0	—	40	ns
t _{DS}	Data Setup Time	70	—	—	90	—	—	ns
t _{DH}	Data Hold Time	0	—	—	0	—	—	ns
t _{AW}	Address to Write Setup Time	0	—	—	0	—	—	ns

* Ta = 25°C, VCC = 5V

CAPACITANCE (Ta = 25°C, f = 1MHz)

SYMBOL	PARAMETER	CONDITIONS	MIN.	TYP.	MAX.	UNIT
C _{IN}	Input Capacitance	V _{IN} = AC Ground	—	—	5	pF
C _{OUT}	Output Capacitance	V _{OUT} = AC Ground	—	—	10	pF

Note: This parameter is periodically sampled and not 100% tested.

TIMING WAVEFORMS

● READ CYCLE

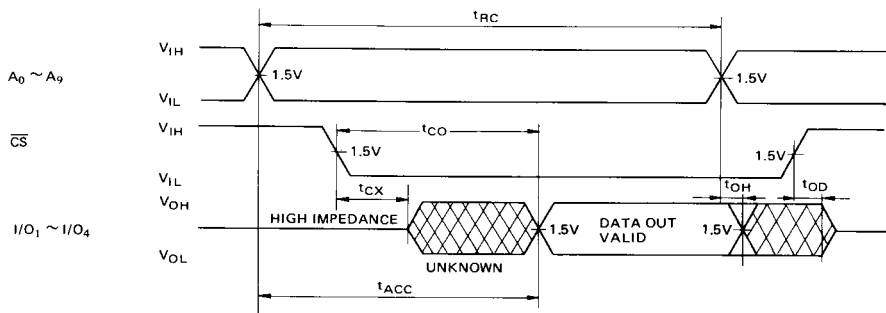

● WRITE CYCLE [1] *(1)

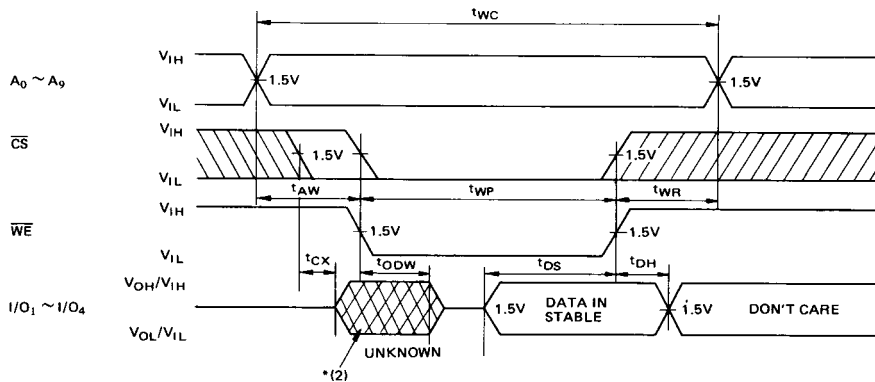

● WRITE CYCLE [2] *(1)

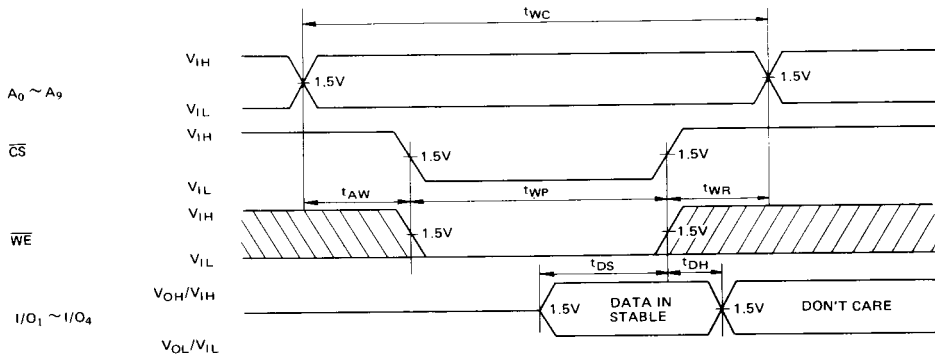

Note *(1): A write occurs during the overlap of a low \overline{CS} and low \overline{WE} .
And t_{wp} is specified as the logical 'AND' of \overline{CS} and \overline{WE} .

*(2): If the \overline{CS} low transition occurs simultaneously with or later from \overline{WE} low transition, the output buffers remain in a high impedance state in this period.

OUTLINE DRAWINGS

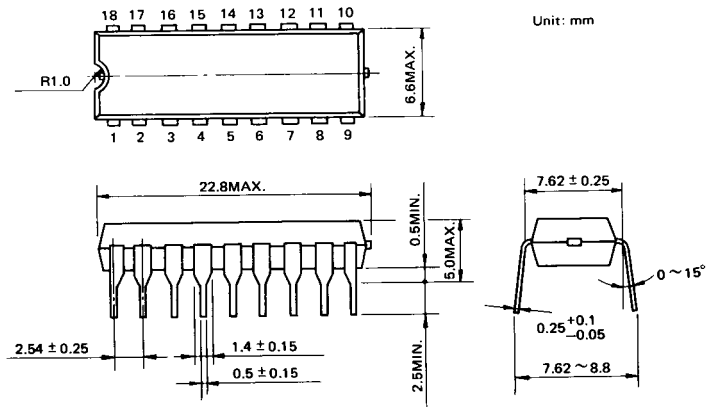

Note: All dimensions are in millimeters. Each lead pitch is 2.54mm.

All leads are located within 0.25mm of their true longitudinal position with respect to No. 1 and No. 18 leads.

This datasheet has been downloaded from:

www.DatasheetCatalog.com

Datasheets for electronic components.