

The Franck-Hertz Experiment

Introduction

The original free-electron/mercury-atom collision experiment was first performed in 1914 by James Franck and Gustav Hertz who were later awarded the 1925 Nobel Prize for their work. Their simple, but elegant research represents one of the key experiments that helped to establish our *Modern Atomic Theory*. In this experiment you will be verifying that atoms can absorb energy only in quantum amounts, thus confirming what was then Bohr's emerging quantum hypothesis.

The basic device is an enclosed glass tube with three electrodes, referred to as a cathode, a control grid, and an anode (see Fig. 1). In addition, there is a small drop of pure mercury placed inside the evacuated tube whose vapor pressure is carefully adjusted by heating this environment. Electrons are thermionically emitted from the cathode, usually heated indirectly by a tungsten filament at a temperature of about 2500 K. The anode is also referred to as the collector and it is negatively biased relative to the control grid by a small potential of about 1.5 volts. The control grid itself is biased by a positive potential V_{accel} relative to the cathode (typically by many tens of volts) and its primary purpose is to accelerate the electrons emitted from the cathode.

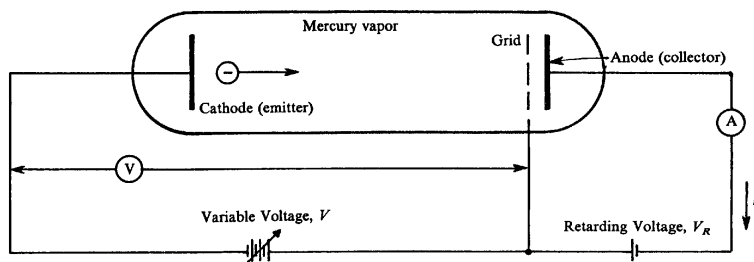

Figure 1: Schematic diagram of the Franck-Hertz tube.

On average, these accelerating electrons will travel a distance, λ , (referred to as the mean free path) before colliding with one of the background mercury atoms. As a result, they will pick up some average increase in kinetic energy before making a collision (either elastic or inelastic). For an elastic collision with a heavy mercury atom, the average energy lost by the electron is negligible. In the worst case, the electron's energy is directed back towards the cathode, but most elastic collisions cause the electron to scatter only through small angles relative to the original direction. This means that we may treat all elastic collisions as if they did not occur (although the elastically scattered electrons do contribute to the baseline slope of current versus V_{accel} plot, and more recent work suggests that elastic collisions play a role in energy loss, especially at low voltages [1, 2]). At some critical value of V_{accel} electrons will acquire enough energy to undergo *inelastic* collisions with the mercury atoms, putting the mercury atoms into excited states. Only inelastic collisions can remove a significant amount of kinetic energy from the free electrons, and the effective mean-free path, λ_{in} , between

inelastic collisions will be much greater than λ .

In general, the excitation cross-sections for an inelastic absorption of energy rise rapidly when the energy of the free electron approaches the energy difference between two stationary states of the excitable atom. You can think of it as a kind of “resonance.” On the other hand, these cross-sections do not drop off to zero immediately after the electron energy exceeds this excitation energy, because energy is not quantized for the *free* electron and it can carry away the energy difference. From Fig. 2, the first possible absorption for mercury (as the accelerating potential is increased) occurs at 4.64 volts, when the atom is promoted from its 1S_0 ground state to the 3P_0 state.

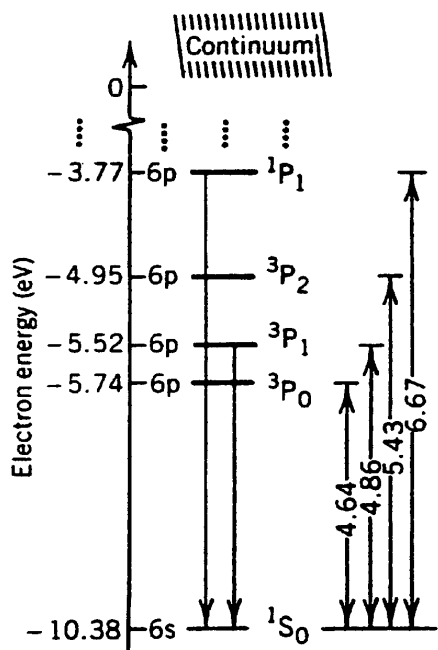

Figure 2: Simplified energy level diagram of mercury, relevant to this experiment. Energy level separation in electron volts is indicated on the right.

Note that no electron current will be sensed by the anode until the accelerating potential exceeds 1.5 volts because of the retarding potential between the collector anode and the control grid. After that, the current is observed to increase with increasing V_{accel} until the first inelastic collision occurs. Electrons that lose this much energy will again not be observed to arrive at the collector because of the retarding potential; they are collected at the grid instead. Those particular electrons will start accelerating again (if V_{accel} is large enough) and possibly later cause another inelastic collision, again to the lowest excited state. Indeed, as the accelerating voltage is further increased, the same electron *may cause atomic excitations multiple times*.

The description of the Franck-Hertz experiment above is necessarily oversimplified. The specific dynamics of electron-atom collisions are quite complicated and have been studied for many years. Modern approaches to the problem involve either direct simulations of the atoms (molecular dynamics) or numerical solutions of a class of differential equations known

as Boltzmann transport equations [2]. Electron-atom collisions in gases are of particular interest to designers of particle detectors, which use such gases to sense the energy of high-energy particles, such as cosmic ray muons or x-rays.

There is still a role for simpler models that can describe essential features of the Franck-Hertz experiment, but go beyond the description given so far. One example is a paper by Rapior, Sengstock, and Baev (RSB), published in 2006 [3]. Among the effects that this model describes are the increasing spacing between peaks (or troughs) in the periodic signal of anode current vs. acceleration voltage, the effect of temperature on the peak spacing in the Hg experiment, and an explanation of why the peak spacing is typically wider than the energy of the first (lowest) excited state of the atom.

As part of the data analysis, you will apply the procedure described by RSB to compare to the simple average-spacing result, and to also see how well their model works with your data set. You will need to read through the paper to learn the details; a copy of the paper is linked on the course website.

You will also run the same experiment for a Franck-Hertz tube containing neon. Neon has a much higher energy for the first excited state, so the peaks in the $I(V_{\text{accel}})$ curve are more widely spaced. Neon also has a more complex energy-level diagram, with two sets of levels that are closely spaced. Excitations to these states also cause the Ne atoms to glow (as they do in “neon lights”), and the pattern of glowing regions can be compared to the $I(V_{\text{accel}})$ curve.

The experiment

Your basic data sets will be plots of anode current versus accelerating potential, V_{accel} , and the corresponding derivative plots using a lock-in amplifier.

For mercury, you will determine the excitation energy for the 6^3P_0 state relative to the 6^1S_0 ground state in mercury.

The curves for neon will look quite different because the minimum excitation energy is much higher and there are many excited states that are close together. These states may be grouped into 4 $3s$ states and 10 $3p$ states which are separated by a gap of about 1.7 eV. A derivative plot of this curve will show striking small features with a separation close to this voltage. You may also take note when visible bands can be observed in neon in relation to magnitude of anode current.

Experimental Goals: (1) Measure the first excited states of Hg and Ne from the anode current versus accelerating voltage curves. (2) Observe the emission of light and the relationship between the light pattern and the anode current curve for Ne. (3) Use the lock-in amplifier to take an experimental “derivative” of the anode current curve, and use this to estimate the energy separation between the $3s$ and $3p$ states of Ne. (4) Apply the model of Rapior, Sengstock and Baev to the data, and see how well it works.

Exercises

1. Calculate the kinetic energy gained on the average by an electron thermionically emitted from an indirectly heated cathode which is typically at a temperature of about $T = 1000^\circ \text{C}$. For this purpose, assume that the average kinetic energy of the emitted electrons is $2kT$. What effect will the distribution of velocities of these electrons have on the sharpness of the peaks in the anode current $I(V_{\text{accel}})$ plot?
2. Estimate the distance, λ , (referred to as the mean free path) that the free electrons will travel on the average before elastically colliding with one of the background mercury atoms. For this purpose, you will need the value for the vapor pressure of Hg found in the *Handbook of Chemistry and Physics*, or the table posted on the course webpage from *Lange's Handbook of Chemistry*. You may use the estimated radius of the neutral Hg atom of 160 pm (picometers) to calculate a collision cross section [4, p. 114].
3. Estimate the worst-case loss of energy that a free electron can have in an *elastic* collision with a mercury atom, assumed on the average to be at rest in the tube.
4. Estimate the longest effective mean-free path, λ_{in} , for inelastic collisions that one could observe in the mercury tube. (Hint, see an old non-functioning Franck-Hertz tube, available in the lab.)

Apparatus and Procedure

Apparatus

The accelerating potential applied to the mercury and neon Franck-Hertz tubes is generated by the electronics inside the Franck-Hertz Ramp Generator box. The time varying potential generated by this box is a ramp waveform that looks like Fig. 3.

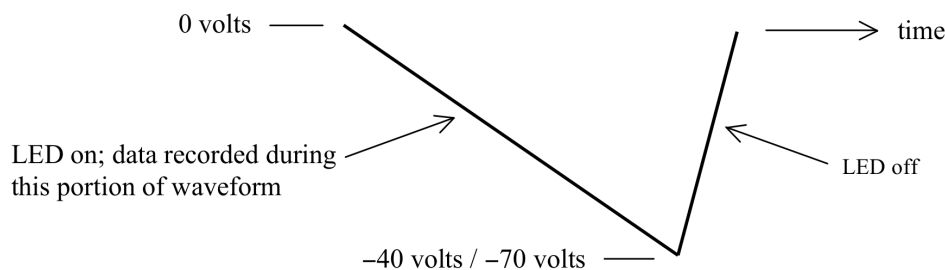

Figure 3: Voltage ramp used to modulate accelerating potential.

The -40 volt potential is applied to the mercury tube, and the -70 volt potential is applied to the neon tube.

For the mercury tube the accelerating potential generated by the box is applied between the cathode and anode, with the anode kept at ground potential. In addition to this time

varying potential, a small static retarding (decelerating) potential is applied between the grid and anode. The retarding potential prevents slower electrons from reaching the anode, thus enhancing the contrast between the minima and maxima in the electron current through the tube. A battery generates the static potential, equal to 1.5 volts in the mercury set-up. The schematic of the cathode, grid, anode and applied potentials is shown in Fig. 4.

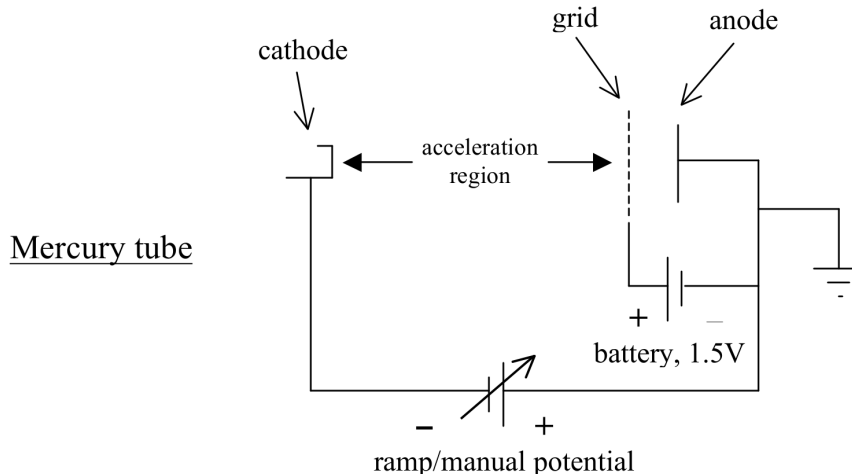

Figure 4: Apparatus schematic for the mercury tube.

The neon tube (Fig. 5) has an additional electrode in the form of a grid located close to the cathode (grid 1). A small fixed potential (1.5 V) is applied between this grid and the cathode to accelerate electrons from the charge cloud surrounding the cathode. The accelerating potential from the Ramp Generator box is applied between the anode, again at ground, and grid 1.

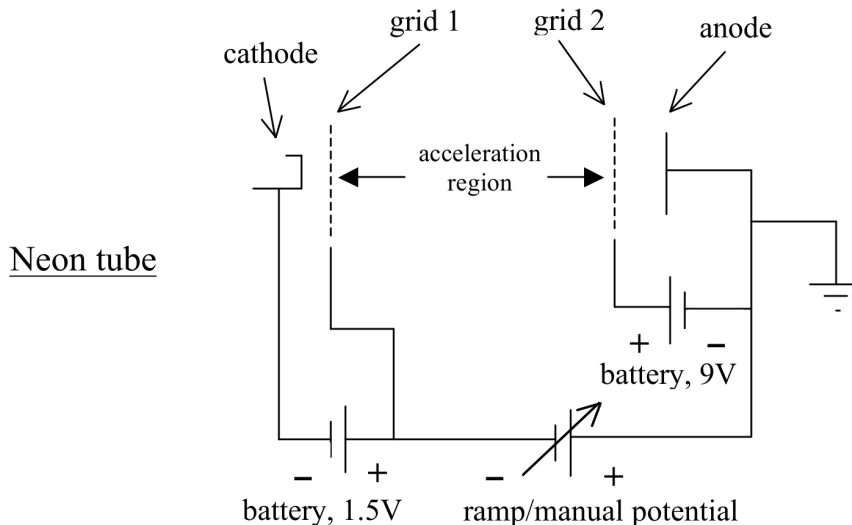

Figure 5: Apparatus schematic for the neon tube.

In both tubes the field that accelerates the electrons is due to the combination of the variable

potential and the fixed retarding potential. The meter which monitors the accelerating potential (between the grid and anode in the mercury set-up, and between the two grids in the neon set-up) will thus indicate a maximum value greater than the maximum potential generated by the box alone.

The Ramp Generator box has a number of features described as follows. The waveform frequency can be set high (50 Hz) or very low (0.03 Hz or 0.004 Hz). The high frequency setting is useful for looking at the ramp waveform on a scope to check out its shape and upper and lower limits. The 0.03 Hz frequency (33 second period) is useful for checking out the X-Y recorder settings to make sure that the pen holder does not hit travel limits during data acquisition. For recording data, the 0.004 Hz frequency (250 second period) should be selected, as this slower speed will allow the electronics and X-Y recorder to more accurately track the signal.

A switch directs the ramp output to either the mercury set-up (0 to -40 volt output connector) or the neon set-up (0 to -70 volt output connector). The ramp output can also be switched off entirely, in which case the selected output is connected to ground.

In addition to generating the accelerating potential like that shown in Fig. 3, the potential can be manually set with the COARSE and FINE 10-turn potentiometers. A switch selects between MANUAL and RAMP (waveform) options.

Data are recorded during the negative-going portion of the waveform. During this portion, the LED is on and the PEN UP/DOWN signal causes the pen on the X-Y recorder to move to the DOWN position. A switch allows the PEN UP/DOWN signal to be disabled, keeping the pen in the UP position. Note: for the Ramp Generator box to control the PEN UP/DOWN movement, the PEN switch on the X-Y recorder must be in the UP position.

When the two power supplies for the Ramp Generator box are first turned on, the ramp output saturates at a positive voltage for a minute or so. (This is also the case when you switch from 33 s to 250 s.) After a while the ramp output will start going negative and will then vary in time as shown in Fig. 3.

Offset and gain controls are also provided to allow for fine tuning these parameters on the output waveform. Normally, these do not need to be changed.

An additional feature of the Ramp Generator electronics is that a small modulating signal can be added to the ramp output, thus allowing for lock-in detection of the derivative of the anode current. The potential differences between successive anode current maxima are the numbers of interest in this experiment, and the lock-in scheme conveniently provides a very sensitive method for detecting the potentials at which these maxima occur. If you are not familiar with this method of lock-in detection, see [5].

Procedure

Mercury set-up

Turn on the Variac controlling the heater in the mercury tube housing and set it to 65 V. This setting will bring the temperature inside the housing to approximately 160 C at equilibrium.

NOTE: the thermostat on the mercury tube housing does not work; temperature is controlled by the Variac setting only. **Keep the Variac setting at or below 65 V**, however, you may turn it up to 100 V for 2–3 minutes at the beginning to warm the oven up more quickly.

With the filament current supply attached to the Hg filament terminals, make sure the output switch is off and the multiturn potentiometer is all the way down to zero. Turn on the power supply for the current source, then the output, and set the current between 210 and 215 mA.

CAUTION: Be very careful when adjusting the filament current. **The filament can easily be burned out by setting the current too high. Do not exceed 215 mA.**

Ramp generator and X-Y Recorder

Check that the MOTORS switch on the X-Y recorder is in the STBY (standby) position. Turn on the X-Y plotter, and also the two power supplies for the Ramp Generator box (the fixed ± 15 V and 5 V, and the Harrison 6294A 70 V supplies). The switches on the Ramp Generator should be set as follows:

PEN UP/DOWN: DISABLE
RAMP PERIOD: 250 SEC
RAMP FREQ: LO
MODULATION VOLTAGE: OFF
RAMP SPAN: 40 VOLTS
OUTPUT: ON
PA81J INPUT: INT
RAMP/MANUAL: MANUAL

Turn the COARSE adjust potentiometer on the Ramp Generator box fully counterclockwise and set the MOTORS switch on the X-Y recorder to OPER (operate). The pen holder should now be near the left edge of the plotting area; if not, adjust the X-axis ZERO control so that it is. Turn the COARSE potentiometer fully clockwise (10 turns). The pen holder should now be near the right edge of the plotting area; if not, check that the sensitivity is set to 2 volts/inch and adjust the VERNIER control (switch below should be in VAR position) so that it is. Turn the COARSE potentiometer fully counterclockwise so that the pen holder is again at the left of the plotting area. DO NOT put a pen in the holder yet.

To record the anode current as a function of accelerating potential, the PDA-700 amplifier output should be connected to the input of the low-pass filter box, and the Y-axis sensitivity on the X-Y plotter set to 5 millivolts/inch. Check that the switch on the filter box is set

to ON. The PDA-700 should be set to 200 nA full scale. (Note: “200 nA full scale” does not mean the output reads “200.00”. It means the output looks like “00.00” with the “nA” showing. The maximum output would be “199.99 nA”.)

With the MANUAL/RAMP switch in the MANUAL position, turn it clockwise to confirm two things: (1) the pen carriage should move up scale and (2) you should see the reading on the PDA-700 increase and then decrease (the current is negative, do you understand why?) If you do not see the pen carriage also go up and down as you increase the ramp voltage, try different gain settings on the Y channel of the recorder. If you fail to get a signal, ask for help.

No check the ramp: switch the OUTPUT from MANUAL to RAMP, and Select the 33 second ramp period. Check the pen holder movement over the entire range of the ramp sweep. The vertical displacement due to the anode current variation should not be more than about half the height of the paper so as to save room for recording the lock-in output on a separate sweep. Select the 250 second ramp period. You may need to wait many seconds until the ramp starts increasing when you choose the 250s period (the internal capacitor is large and takes a while to reach its steady state operating potential).

After the 250s cycle is working properly, set the chart recorder MOTOR switch to STBY and pop a pen in. Then set the MOTORS to RUN and wait until the pen starts moving to the left to flip the PEN UP/DOWN switch on the ramp generator box to ENABLE. The system is now ready to record the anode current.

After the data acquisition sweep is completed and the pen holder starts moving to the left, set the PEN UP/DOWN switch to DISABLE.

A copy of sample data is available in the lab to give you an idea of what the anode current curve (and derivative curve) looks like.

Lock-In Amplifier Use

Once you have satisfactorily recorded the anode current, the next step is to use the lock-in detector to record the derivative of the anode current. The derivative curve will show the correlation between the zeroes of the derivative and the maxima of the current.

CAUTION: It is important to not change the X-axis ZERO setting after recording anode current, as the ZERO must stay the same to correlate the maxima of the anode current with the zeroes of the lock-in output.

Move the pen holder vertically to the unused portion of the plotting area with the Y-axis ZERO adjust. Switch the Y-axis sensitivity to 500 mV/inch (slide the switch from X1 to X100). Flip the “Plotter Y-axis” switch on the switch-box from “PDA-700” to “Lock-in”. Set the MODULATION VOLTAGE switch on the Ramp Generator to ON.

Recommended settings for the SR830 are:

TIME CONSTANT: 300 mSec, 12 dB/octave, SYNC filter OFF
SIGNAL INPUT: A, DC coupled, Grounded
SENSITIVITY: 2 millivolt
RESERVE: NORMAL
FILTERS: Line, 2X line, both on
CHANNEL 1: X
CHANNEL 1 OUTPUT: X
REFERENCE PHASE: 0.00 degrees
REFERENCE AMPLITUDE: 20 millivolts (This is an rms level and will result in a 20 millivolt peak to peak voltage being added to the ramp waveform.)
REFERENCE FREQUENCY: 210 Hz
SOURCE: INTERNAL

Select the 33 second ramp period and check that the pen holder movement due to the variation of the lock-in output is reasonable (doesn't overlap anode current curve much; a little overlap is OK) over the entire range of the ramp sweep.

Select the 250 second ramp period. Again, the ramp output will be at some arbitrary phase of the ramp cycle. Wait until the pen starts moving to the left, and then set the PEN UP/DOWN switch to ENABLE. The system is now ready to record the derivative of the anode current. After the sweep is completed and the pen holder starts moving to the left, set the PEN UP/DOWN switch to DISABLE.

After recording the derivative curve, make a trace of the zero of the lock-in output to locate the zeroes on the derivative curve. To do this, flip the switch on the RC filter box to OFF and record another trace. Then set the PEN UP/DOWN switch to DISABLE.

You can confirm the "derivative" curve of the lock-in by using the MANUAL adjust of the accelerating potential to accurately find the maxima of the anode current curve. Adjust the accelerating potential with the COARSE 10-turn potentiometer until you are near the first prominent maximum in the anode current. Carefully adjust the COARSE and then FINE controls until the lock-in output is zero (it will always show some fluctuations). Record the value of the accelerating potential. Set the PEN switch on the X-Y recorder to DOWN, and using the Y-axis ZERO control, make a vertical line on the graph paper. This line should intersect the lock-in output curve at or near a zero, and should intersect the anode current curve at or near the maximum. Repeat this procedure for a few (or all) maxima and minima.

One could obtain the important voltages in this way, although a more general procedure (that is also less work) is to make a calibration of the scale itself. With the RC switch box OFF, adjust the Y-axis zero to be near the bottom (or middle, your choice) and set the accelerating voltage to exactly 0.00 volts (use both coarse and fine adjust knobs), drop the pen, and make a short vertical line. Raise the pen, and move the accelerating voltage to exactly 10.00 V, and make another line. Proceed in this way until you have covered the full voltage range.

To find the voltage for any feature, you need to create a translation between the printed

scale of the graph paper (in units of 1/10 inch) to voltage. Locate the scale position in these units for each calibration mark, and create a table with X values equal to the mark position and Y values equal to the voltage at that position. Then plot an fit this set of points. You will get a fit line with coefficients that allows you to calculate the voltage given the scale position of any feature.

When you are done collecting data for the mercury tube, turn the filament current down to zero and shut off the filament supply, and turn the Variac down to zero and switch it off.

Neon set-up

The procedure for the recording the anode current as a function of the accelerating potential is very similar to that described above for the mercury set-up. Switch the RAMP SPAN to -70 volts; this will automatically connect the output to the 70 volt connector. Check that the X-Y recorder for the neon set-up is set at 5 volts/inch on the X-axis and 20 millivolts/inch on the Y-axis. (Remember to switch the “Plotter Y-Axis” back to “PDA-700”.)

Turn the current control knob on the filament current supply (now attached to the Hg tube) box fully counterclockwise so that it reads 0. Turn it off and also turn off the power supply (little HP6213A). Disconnect the leads from the HG supply and connect them to the Ne tube base. Note polarity of these leads.

After connecting the current source to the Ne base, turn on the HP power supply and set it to 10 volts. Then turn on the output switch and increase the neon tube filament current to 240–245 mA. A filament current in this range should make for easily visible bands when the accelerating potential is applied to the tube.

CAUTION: Be very careful when adjusting the filament current. **The filament can easily be burned out by setting the current too high.**

Repeat the procedure for making an X-Y recording as described above for mercury in Sec. 1, with the exception that the X-Y recorder settings and ramp span are bigger here. You may also need to use different settings on the PDA-700 than you did for Hg. Play with the gains until you see a clear signal that covers a large area on the X-Y recorder page.

The neon tube has the interesting feature that as the accelerating potential increases, bright and dark bands appear in the region between the two grids. With the room lights low and the cover over the tube, these bands are clearly visible. Try to correlate the changes in appearance of the bands with what you observe on the anode current trace.

Take a lock-in trace, following the same procedure as for the Hg tube. Here, the goal is more than just noticing that the derivative curve is created. Look carefully at the anode current curve for neon. Note the small bumps or inflections that are visible near the troughs. These inflection are changes in the slope of the curve, and they can be “amplified” by the lock-in to appear as small peaks.

The origin of these small features comes from the fact of two closely-spaced sets of excitation levels. For a subset of the electrons, there will be one (inelastic) collision at about 16.7 eV followed by a collision at 18.6 eV (or so) near the second minimum. At the third minimum,

one will see other combinations: 2 collisions at 16.7 eV followed by another at 18.6 eV, or 1 collision at 16.7 followed by two at 18.6 eV. In general, the various combinations produce other periodicities in the anode current curve. Overall, the small features should be separated by about 1.7 eV, equal to the difference between the $3s$ states and the $3p$ states. You may use the lock-in peaks to check this.

Shutdown

When you are finished, turn the filament current setting down to zero and switch the filament off. Also check that the current setting for the mercury tube filament has been turned down to zero. Turn off all the electronics, and make sure the Variac supplying the heater in the mercury tube housing is turned down to zero and switched off.

References

- [1] McMahon, D. R. A., “Elastic electron-atom collision effects in the Franck-Hertz experiment,” *Am. J. Phys.* **51**, 1086 (1983).
- [2] Sigenege, F., R. Winkler, and R. E. Robson, “What really happens with the electron gas in the famous Franck-Hertz experiment?” *Contrib. Plasma Phys.*, **43**, 178–197 (2003).
- [3] Rapior, G., K. Sengstock, and V. Baev, “New features of the Franck-Hertz experiment,” *Am. J. Phys.*, **74**, 423–428 (2006).
- [4] John Emsley, *The Elements*, Oxford University Press (1989).
- [5] Paul Horowitz and Winfield Hill, *The Art of Electronics*, 2d ed., pp. 1030-1034 (1989).

Prepared by J. Stoltenberg, D. B. Pengra, and J. A. Detwiler
franck-hertz_2020.tex -- Updated 30 April 2020.