

Collective and Swarm Intelligence in Natural and Artificial Systems.

Andres Perez-Urbe

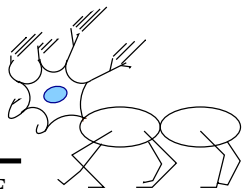



Swarm intelligence

Researchers are interested in a new way of achieving a form of artificial intelligence, called

swarm intelligence,

or the emergent collective intelligence of groups of simple agents.

The term has been used to refer to "any attempt to design algorithms and distributed problem-solving devices inspired by the collective behavior of social insect colonies and other animal societies."

Bonabeau, Dorigo, Theraulaz, *Swarm Intelligence*, 1999

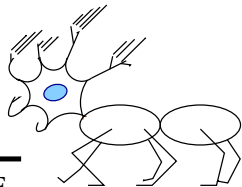



Collective problem-solving

The Swarm Intelligence approach argues that there may exist an alternative approach to problem solving that operates at a level above our traditional problem solving processes.

"Problem-solving can occur at a level above a collection of idealized agents, without "intentional solving" on the part of the individual."

N.L. Johnson, Collective Problem Solving, LANL tech-report, 1998.

In other words, the individual agents do not know they are solving a problem, but their collective interaction so solve the problem.

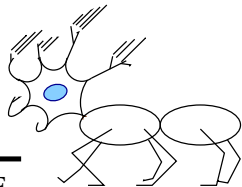



Example: searching books by using amazon.com recommendations

amazon.com.

The recommended book lists at this online bookstore are constructed by displaying, according to frequency, the books that were purchased by people that also purchased the found book.

Emergent functionality:

These lists, for instance, are very useful to search a sequence of related books until a desired book is found.

Given that the possible choices exceed a million books, humans would have great difficulty with the success rates of this recommendation method.

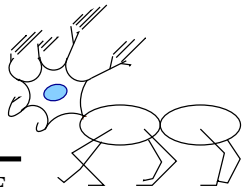

Collective animal locomotion



Flock



School



Swarm

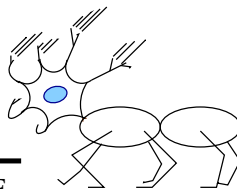

Collective animal locomotion



Procession



Formation



Herd

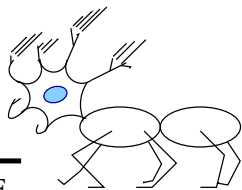

Boids: generic simulated flocking creatures

by Craig Reynolds, 1986.

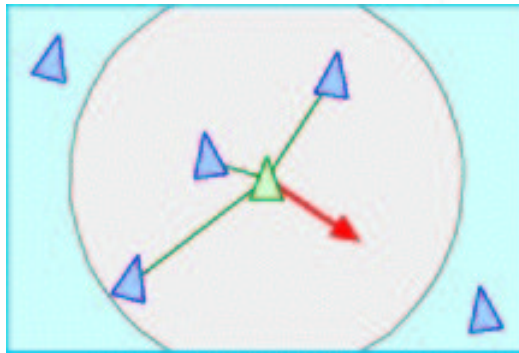

separation: avoid crowding local flockmates.

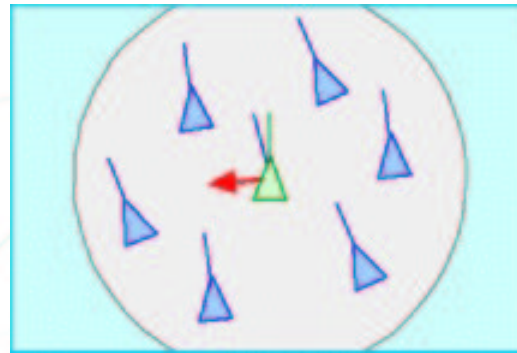

alignment: steer towards the average heading of local flockmates.

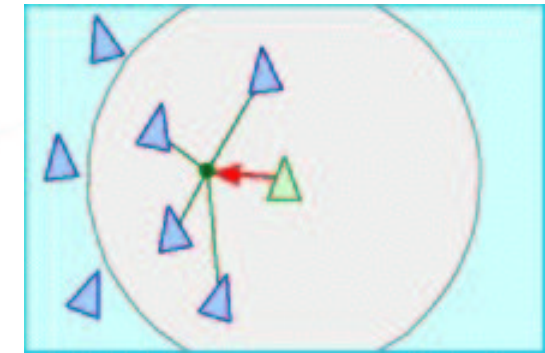

cohesion: steer to move forward the mean position of local flockmates.

Example of locomotion (from Scientific American, Nov/2000)

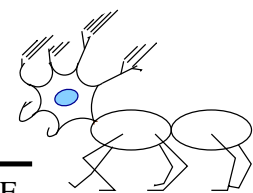
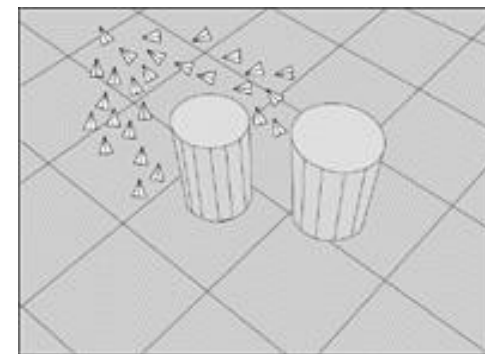
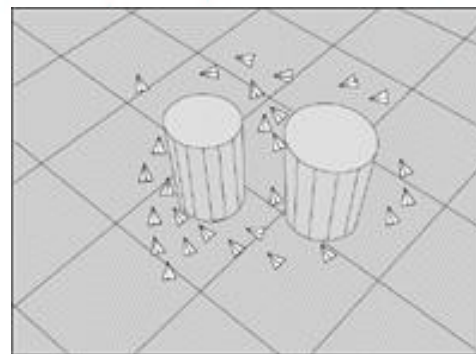
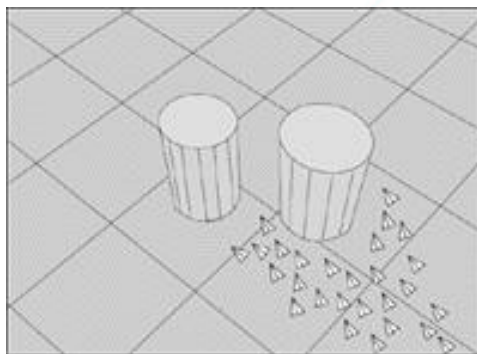



Collective behavior: how does it work ?

As far as individual's behavior is concerned:

by using the same abilities as solitary individuals

- respond to specific sensory inputs by stereotyped actions using: local sensing, local action, little or no memory
- exploit the interactions of these behaviors with the environment

and

by having some behaviors closely tuned to the actions and consequences of actions of other individuals.

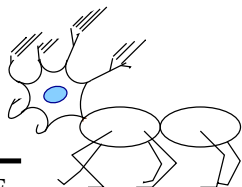

Collective behavior: the case of insect societies

"individual simplicity and collective complexity"



termites nest
(by R. Thiel)



"living bridges"
of ants made by ants

- The behavioral repertoire of insects is limited.
- A single individual has not access to all necessary information about the state of the colony to make decisions that favor the progress of the colony.
- The colony as a whole is the seat of a stable and self-regulated organisation of individual behavior which adapts itself to environmental changes.

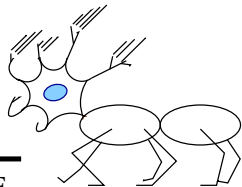



Collective behaviour of insects

When one observes an insect colony it appears that every single insect has its own agenda....

yet, the whole colony looks very organized.

What is really amazing is that the seamless integration of all individual activities does not seem to require **ANY SUPERVISOR!**

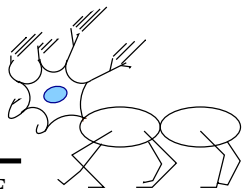



Collective behavior coordination

Insect societies have developed systems of collective decision making operating without symbolic representations, exploiting the physical constraints of the environment in which they have evolved, and by using:

- direct communication (when in contact)
- indirect communication (via the environment), or "stigmergy"

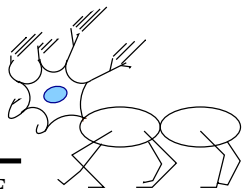

Stigmergy

"Stigmergy occurs when an insect's actions are determined or influenced by the consequences of another insect's previous action"

E. Bonabeau

Example: nest building (after P. Grasse, 1959)

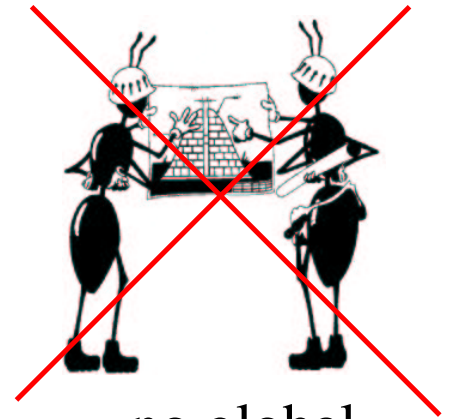

no global plans

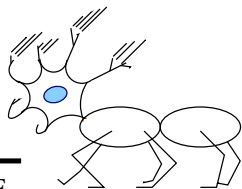
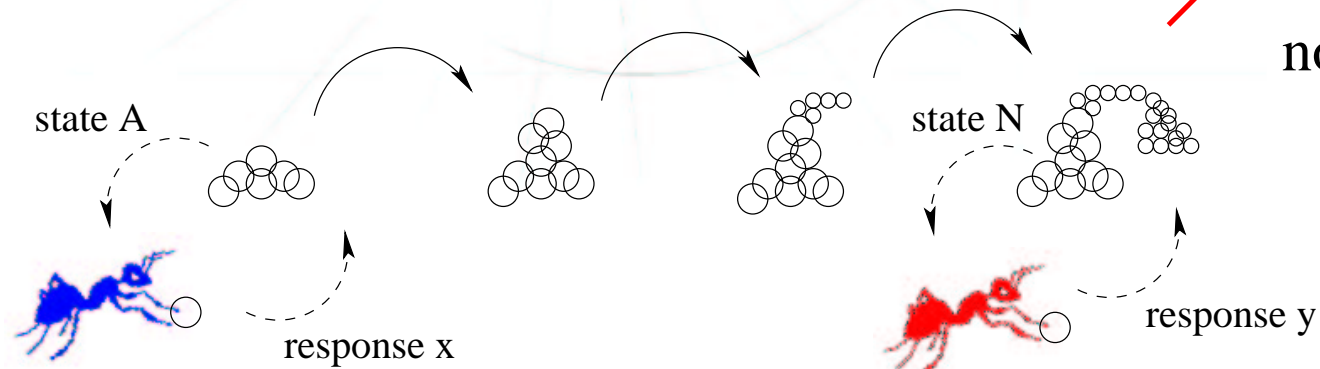

Stigmergy example: clustering

- corpse clustering in ants
(*Lasius niger*, *Pheioide palludila*)
- object clustering with Khepera robots



- Pick up an item with high probability if few items are perceived nearby
- Drop an item with high probability if lots of items are perceived nearby

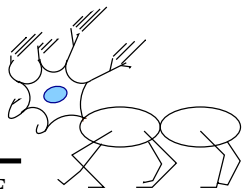

Stick pulling experiment (Ijspeert et al., 2001)

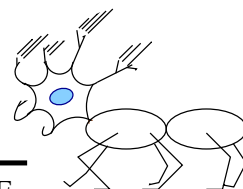
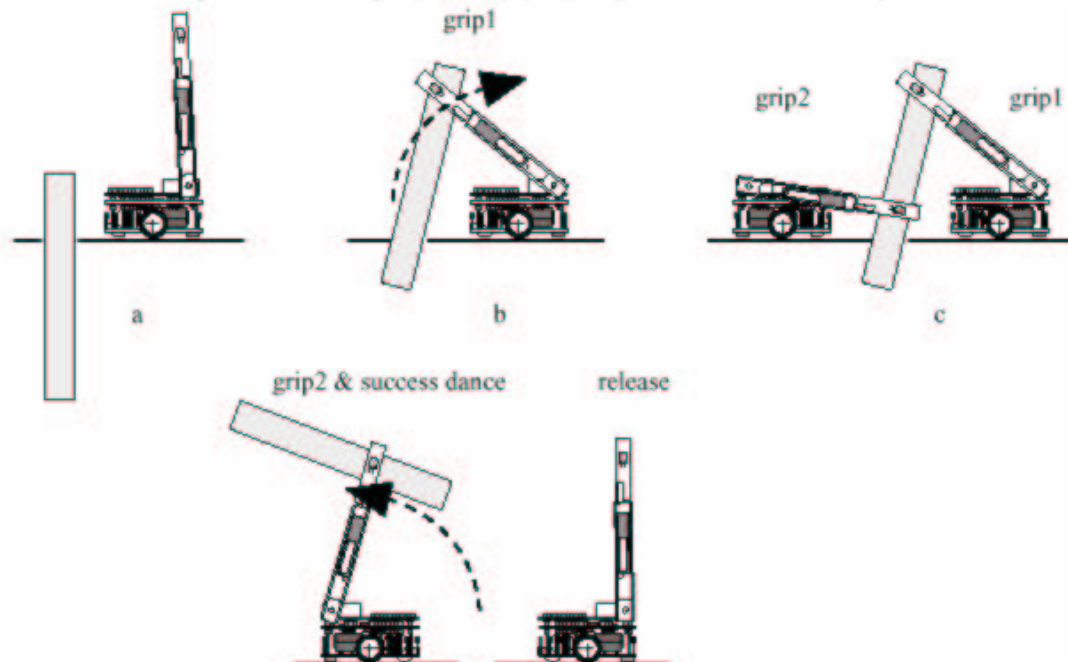
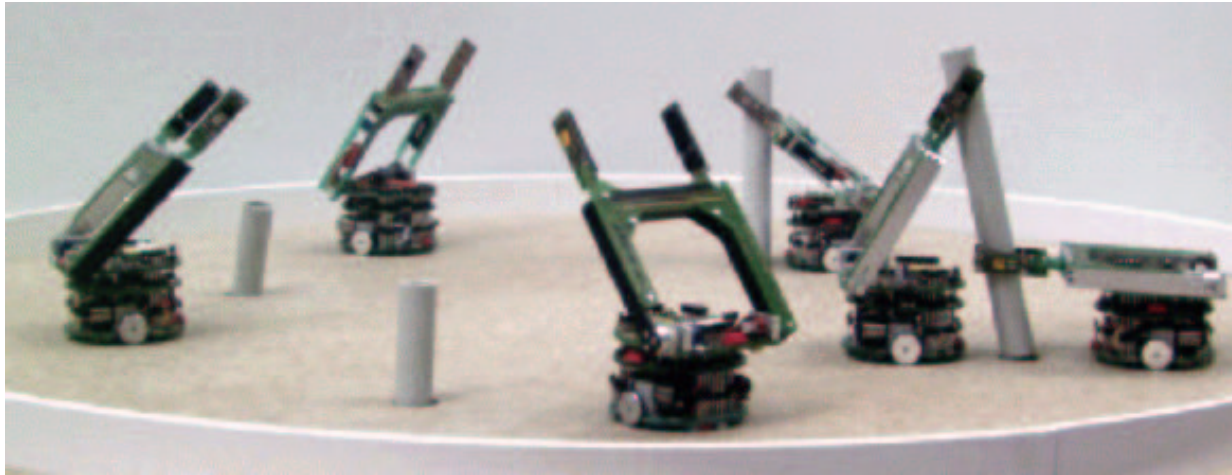

Self-organization

"The essence of self-organization is that system structure often appears without explicit pressure or involvement from outside the system. In other words, the constraints on form (i.e., organization) are internal to the system, resulting from the interactions among the components and usually independent of the physical nature of those components".

SOS-FAQ

Ingredients:

- positive feedback (e.g., attraction, recruitment)
- negative feedback (e.g., saturation)
- amplification of fluctuations (e.g., formation of seeds for growth)
- multiple interactions

Example: ant nest holes

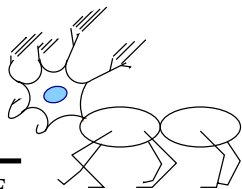
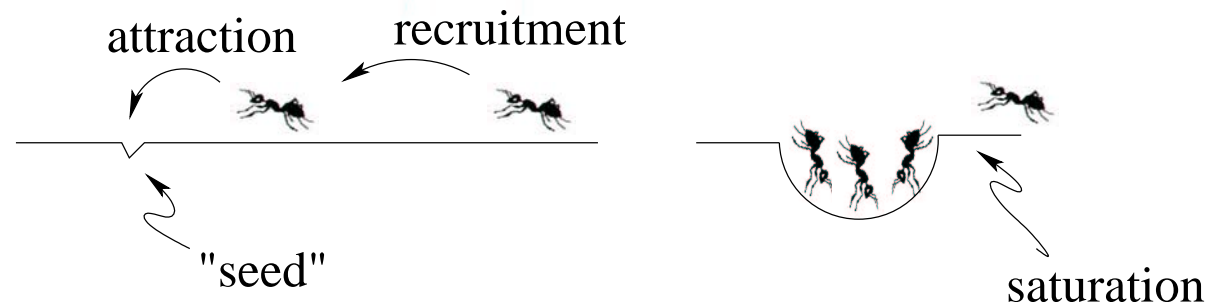

Social insects, altruism, and genes

social insects = perfectly well organised groups of altruistic individuals.

- Kin selection:
Hamilton (60's) based on
Fisher (30), Haldane(55)
problem: kin recognition

relatedness between sisters:

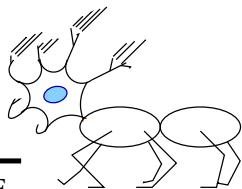
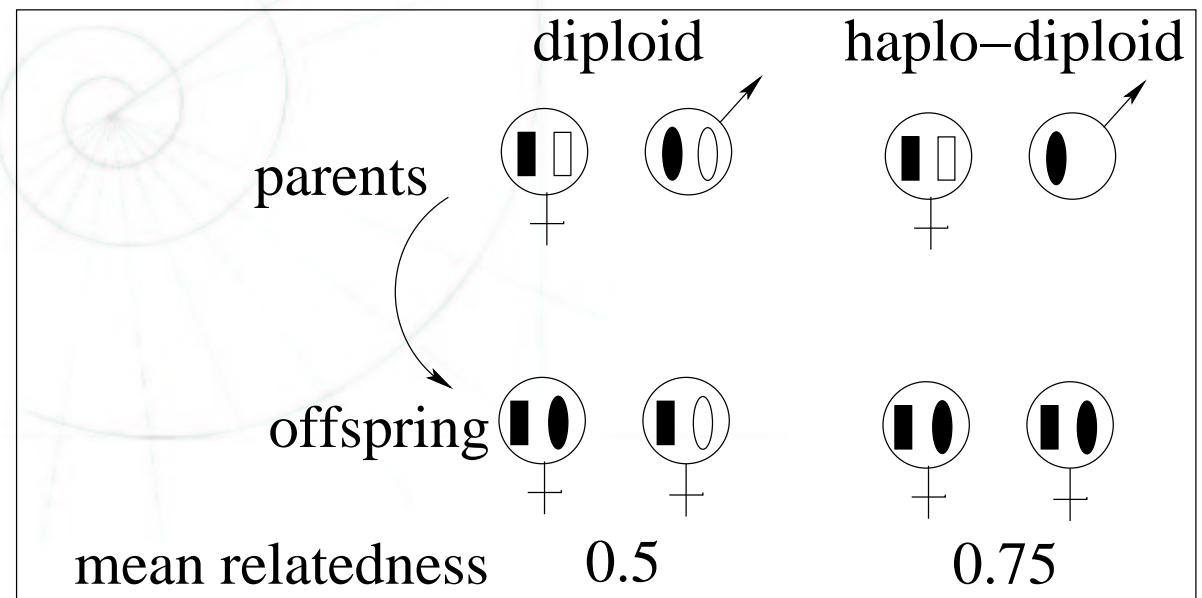

Specialization/division of labour

Social insects have also achieved their enormous success thanks to function and morphology specialization:

- reproductive queens and sterile workers and soldiers
- some workers take care and feed cocoons
- some workers search for food while soldiers watch the nest
- some workers keep herds of aphids (small plant-sucking insects)
- some workers became "storage tanks" of honey
- etc, etc, etc....

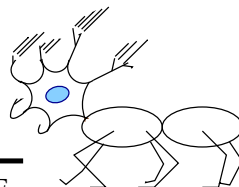

Benefits of concurrent operation and division of labour

1) 1 individual, 3 acts

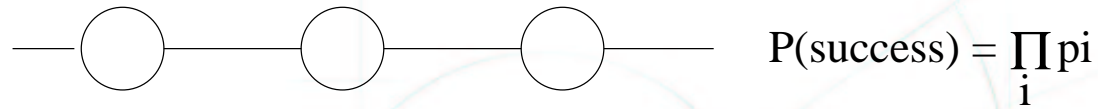

2) 2 individuals, 3 acts (concurrent operation)

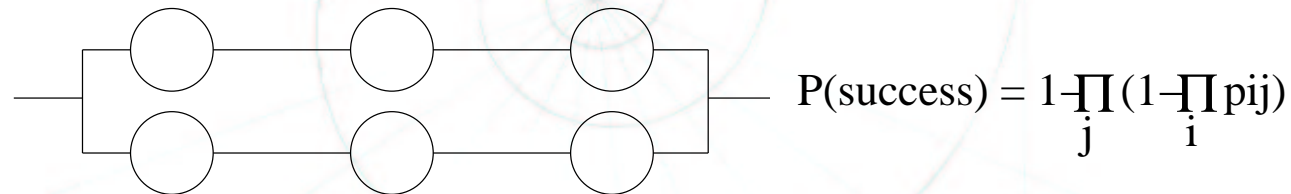

3) 2 individuals, 3 acts (division of labour)

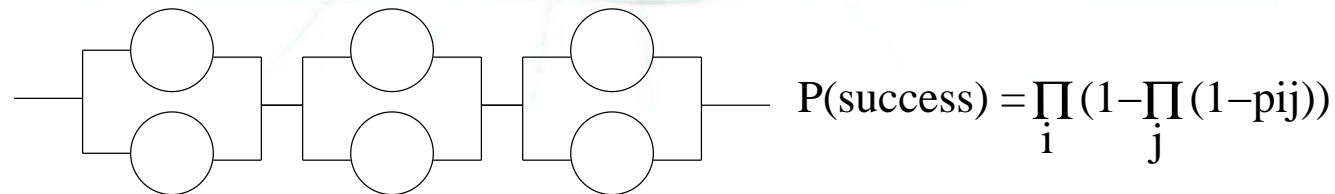

p_{ij} = prob. that j th individual accomplish task i th successfully

Example: $p_{ij}=0.3$, $i=1,2,3$ and $j=1,2$, $P_1=0.027$, $P_2=0.054$, $P_3=0.133$

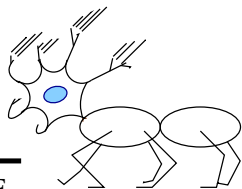

Ant algorithms

Inspired by observations of Goss et al, 1989
and Deneubourg et al. 1990

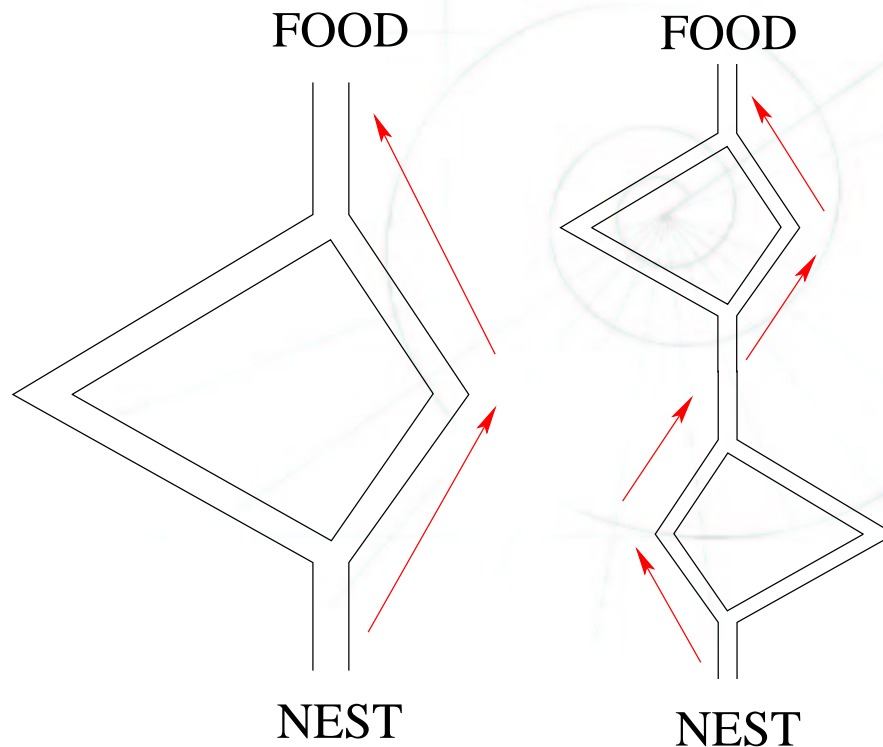

Ant pheromone trails
direct the colony in
the search of shortest
path solutions on graphs.

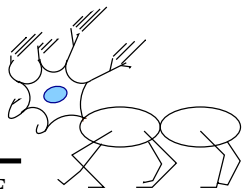

Ant Colony Optimization (ACO)

An application to the Traveling Salesman Problem (TSP)
(Dorigo, Gambardella, 1997)

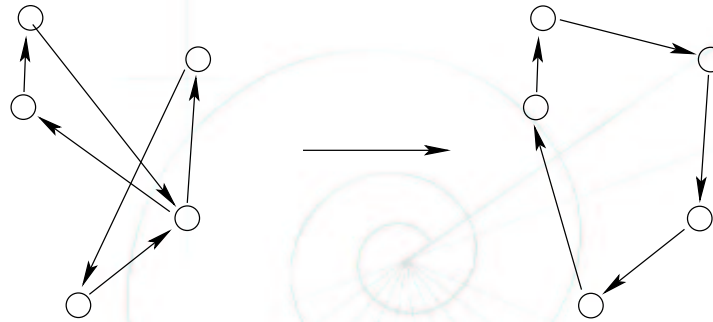

- use a colony of artificial ants (agents)
- each ant agent starts in a random city and uses a probabilistic rule to choose a path
- each ant agent remembers the cities it has visited and deposits "pheromone" along its path
- the deposited pheromone influences the probabilistic rule used by the ant agents to choose their path

a good TSP solution is found after a certain number of iterations

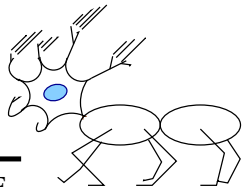

Ant System algorithm (Dorigo et al. 1991)

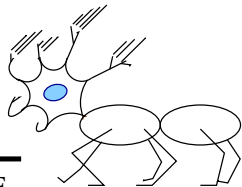
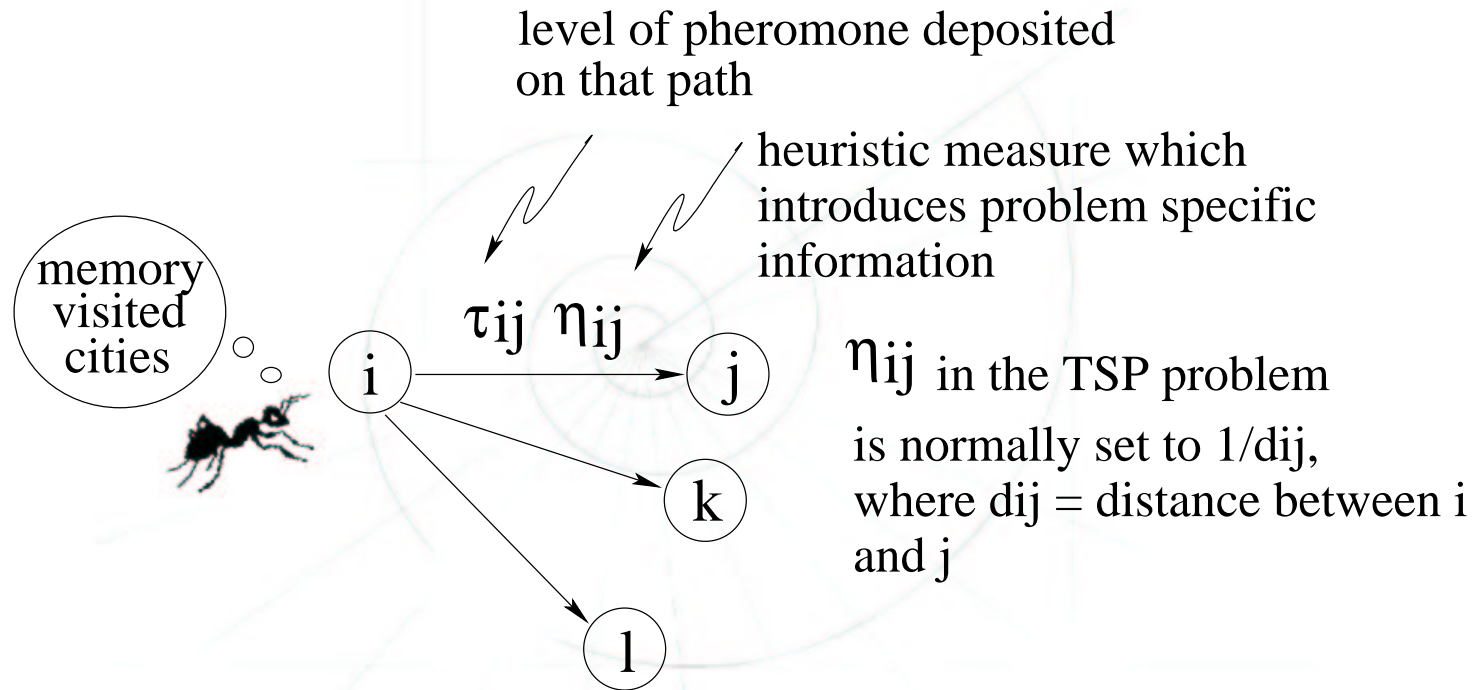



Ant System transition rule:

Probabilistic transition rule:

$$p_{ij}^k(t) = \frac{[\tau_{ij}(t)]^\alpha [\eta_{ij}(t)]^\beta}{\sum_{h \in J_i} [\tau_{ih}(t)]^\alpha [\eta_{ih}(t)]^\beta}$$

* probability for ant k to go from city i to city j

- if city j has been visited $\rightarrow p_{ij} = 0$
- alpha and beta are parameters that trade-off global/local information:
- if alpha is small, the nearest cities are favored
- if beta is small, pheromone level is favored, the ants might choose non-optimal paths too quickly.

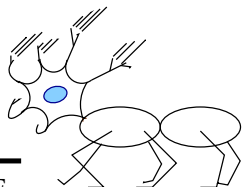



Ant Colony Optimization (ACO)

Exploration–exploitation:

- q_0 is a tunable parameter where $0 < q_0 < 1$
- During the probabilistic path selection:
 - if $\text{rand}() > q_0$, select a random city j using the formula for p_{ij} , but with $\alpha=1$
 - if $\text{rand}() < q_0$ select the city with the best pheromone–distance profile
- if q_0 is close to 1, only locally optimal solutions are selected
- if q_0 is close to 0, all solutions are explored

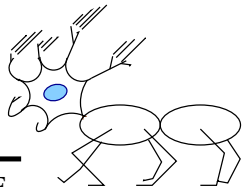



Ant Colony Optimization (ACO)

Pheromone trail depositing: local + global updating rules

- a) The ant that generated the best tour since the beginning of a trial globally updated the pheromone trail levels (τ_{ij}).

For every edge i,j :

Global update rule:

$$\begin{aligned}\tau_{ij}(t+1) &= (1 - \rho)\tau_{ij}(t) + \rho\Delta\tau_{ij}(t), \\ \Delta\tau_{ij}(t) &= 1/L^+\end{aligned}$$

where, L^+ = shortest-tour length found so far.

This encourages ants to search for paths in the vicinity of the best path found so far (exploitation).

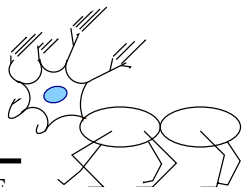



Ant Colony Optimization (ACO)

Pheromone trail depositing: local + global updating rules

b) All ants perform a local pheromone (τ) update as follows:

$$\tau_{ij}(t + 1) = (1 - \rho)\tau_{ij}(t) + \rho\tau_0 \quad (\text{rho is a constant value})$$

when selecting city j from city i .

$\tau_0 = 1/(nL_{nn})$ is the initial pheromone level, n is the number of cities, and L_{nn} is the length of the best greedy tour.

When an ant visits an edge, the pheromone is diminished thus favoring edges not yet visited (exploration).

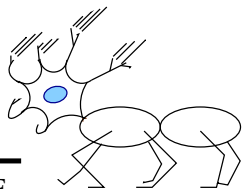



Ant Colony Optimization (ACO)

Performance:

- ACO finds the best solutions on small problems (30 cities)
- ACO converges to good solutions on larger problems.
- Coupling ACO with local optimizers gives world-class results.
- ACO does not beat specialist programs on "static" problems like TSP, ants are "dynamic" optimizers.

Example of dynamic problems:

computer network routing

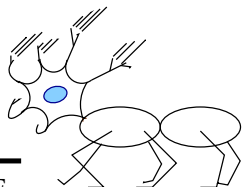



Concluding remarks

Swarm intelligence: a natural model of distributed problem–solving

- Collective systems are capable of accomplishing difficult tasks, in dynamic and varied environments, without any central coordination.
- Collective systems can solve tasks that a single individual cannot.
- Collective systems can achieve a problem–solving performance that single individuals cannot achieve.

