

Ling 566
Oct 15, 2019
How the Grammar Works

Overview

- What we're trying to do
- The pieces of our grammar
- Two extended examples
- Reflection on what we've done, what we still have to do
- Reading questions

What We're Trying To Do

- Objectives
 - Develop a theory of knowledge of language
 - Represent linguistic information explicitly enough to distinguish well-formed from ill-formed expressions
 - Be parsimonious, capturing linguistically significant generalizations.
- Why Formalize?
 - To formulate testable predictions
 - To check for consistency
 - To make it possible to get a computer to do it for us

How We Construct Sentences

- The Components of Our Grammar
 - Grammar rules
 - Lexical entries
 - Principles
 - Type hierarchy (very preliminary, so far)
 - Initial symbol (S, for now)
- We combine constraints from these components.
 - Q: What says we have to combine them?

An Example

A cat slept.

- Can we build this with our tools?
- Given the constraints our grammar puts on well-formed sentences, is this one?

Lexical Entry for *a*

$\langle a, \rangle$	$\left[\begin{array}{l} \text{word} \\ \\ \text{SYN} \\ \\ \text{SEM} \end{array} \right.$	$\left[\begin{array}{l} \text{HEAD} \\ \\ \text{VAL} \\ \\ \text{MODE} \\ \text{INDEX} \\ \text{RESTR} \end{array} \right.$	$\left[\begin{array}{l} \text{det} \\ \text{AGR} \\ \text{COUNT} \\ \\ \text{COMPS} \\ \text{SPR} \\ \text{MOD} \\ \\ \text{none} \\ j \\ \left\langle \left[\begin{array}{l} \text{RELN} \\ \text{BV} \end{array} \right] \right\rangle \end{array} \right.$	$\left[\begin{array}{l} \\ \\ 3sing \\ + \\ \\ \langle \rangle \\ \langle \rangle \\ \langle \rangle \\ \\ \\ a \\ j \end{array} \right.$	\rangle
----------------------	---	--	---	--	-----------

- Is this a fully specified description?
- What features are unspecified?
- How many word structures can this entry license?

Lexical Entry for *cat*

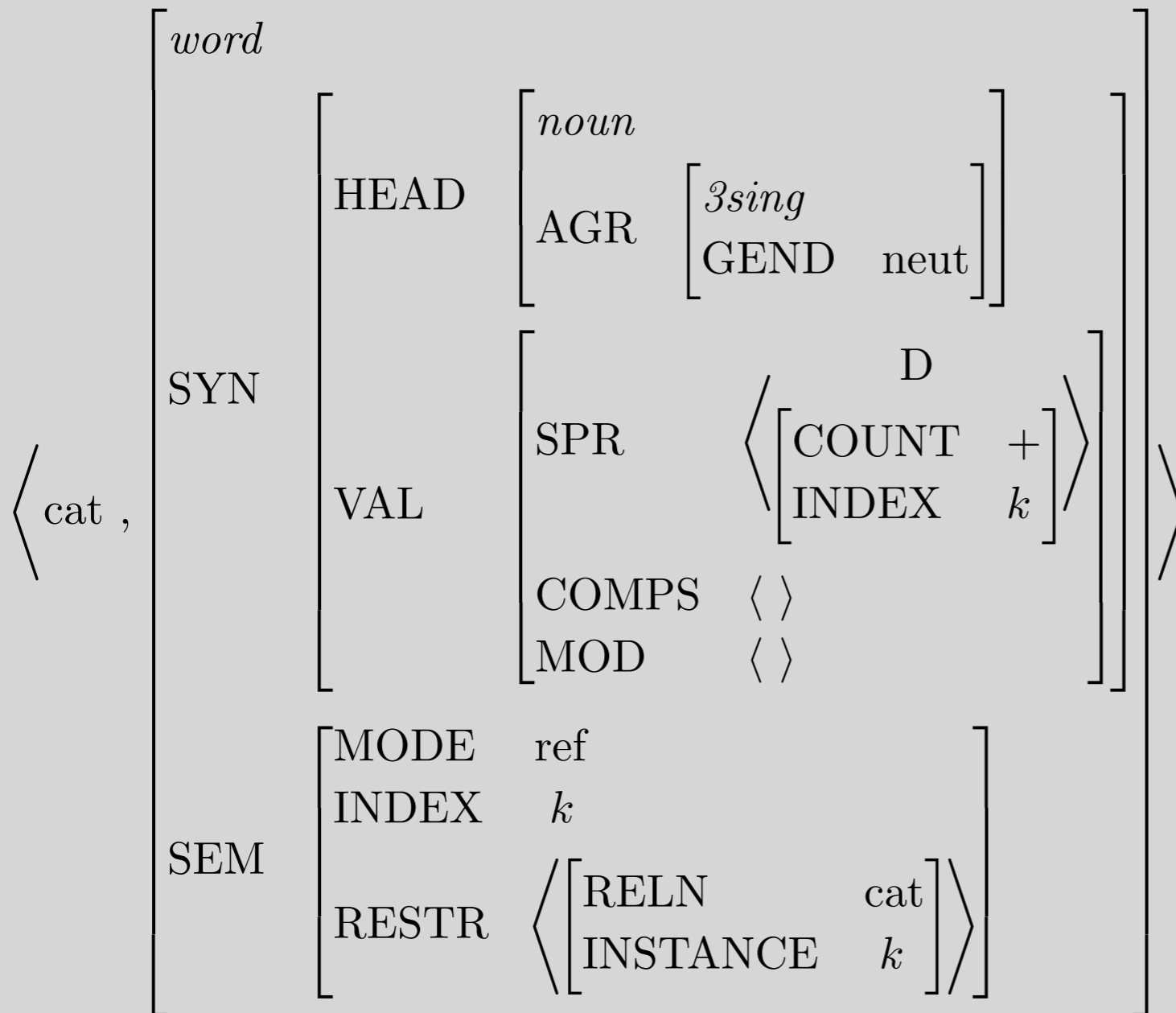

- Which feature paths are abbreviated?
- Is this a fully specified description?
- What features are unspecified?
- How many word structures can this entry license?

Effect of Principles: the SHAC

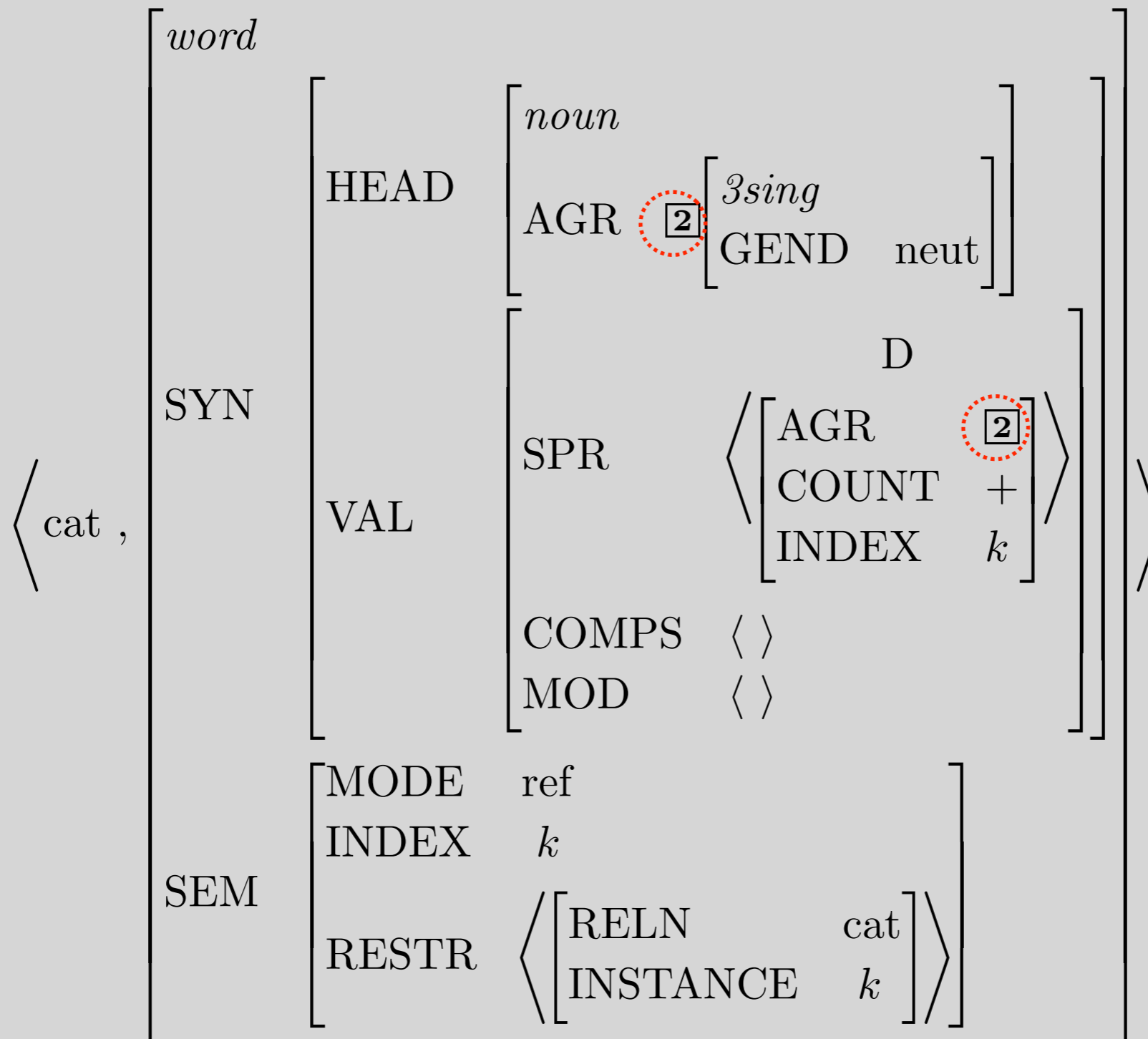

Description of Word Structures for *cat*

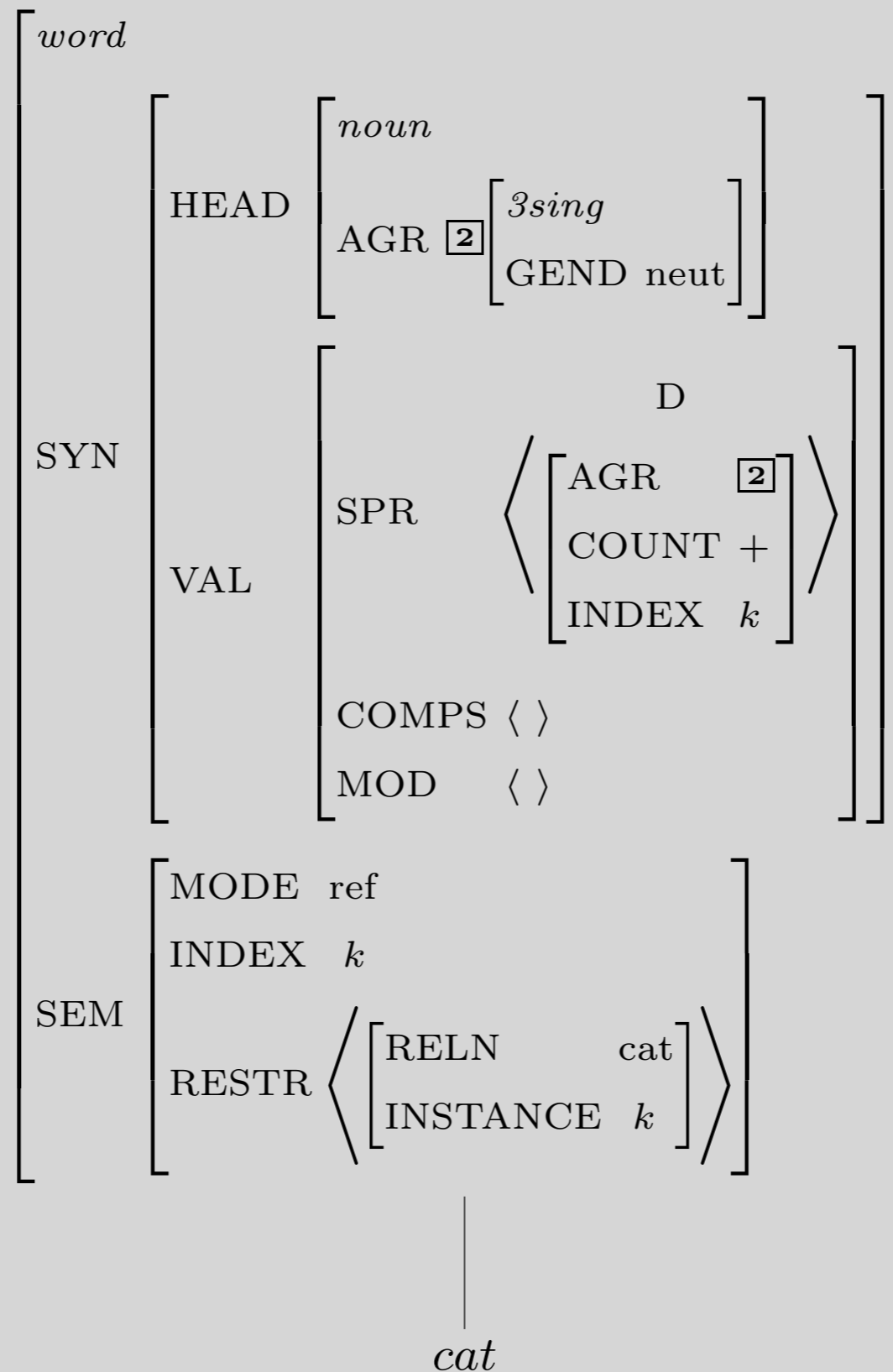

Building a Phrase

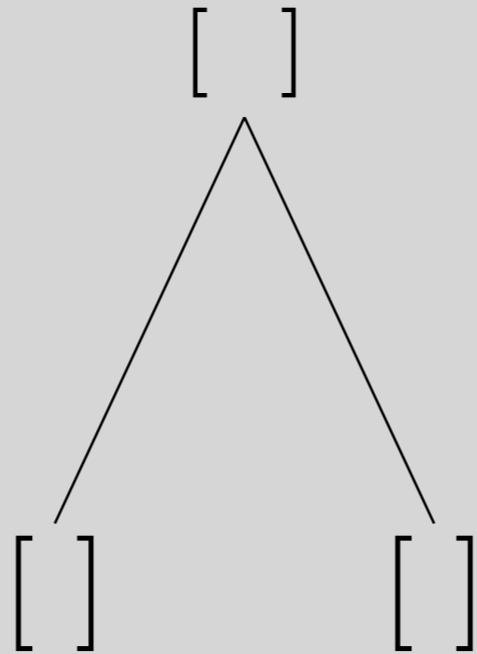

Constraints Contributed by Daughter Subtrees

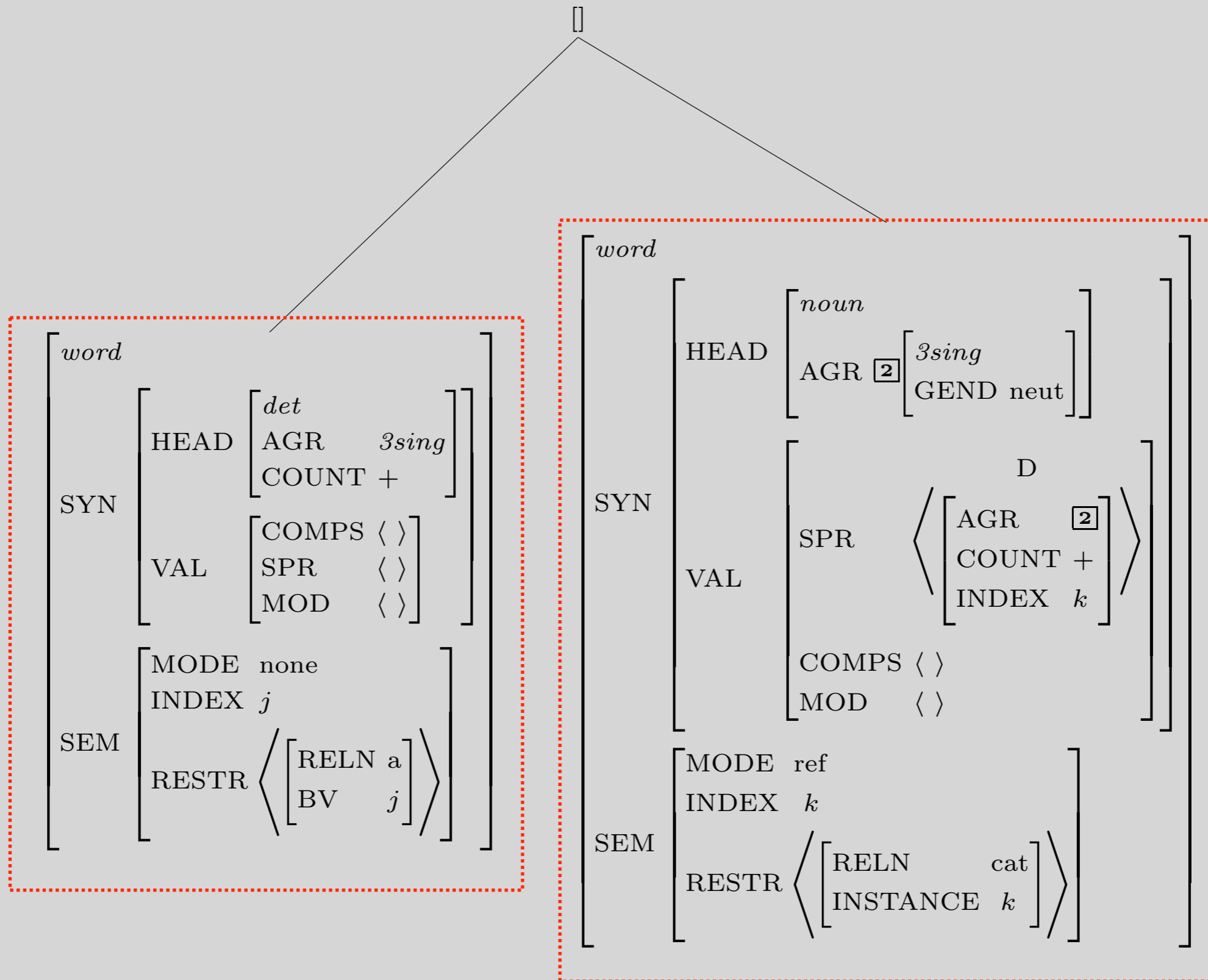

Constraints Contributed by the Grammar Rule

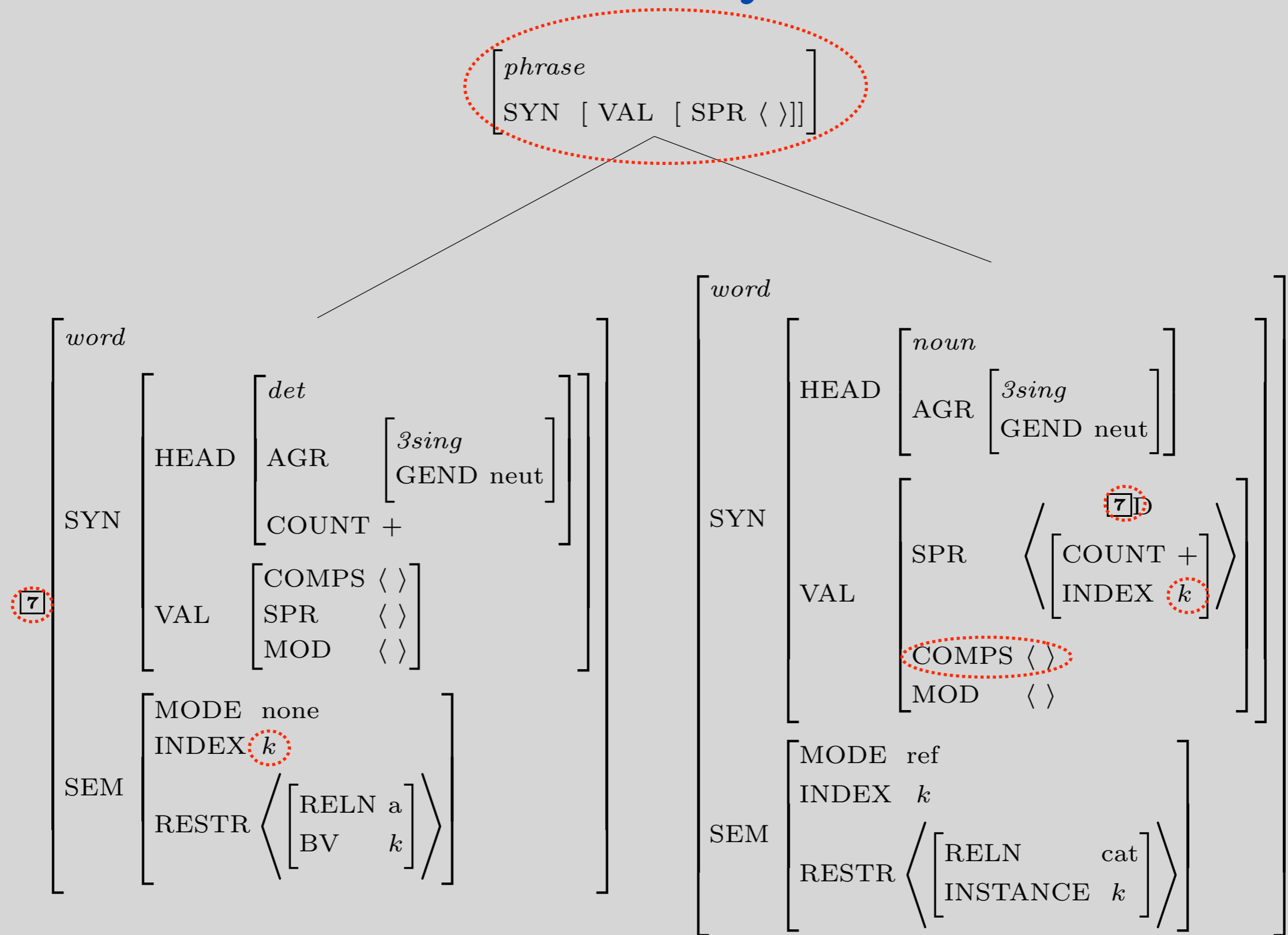

A Constraint Involving the SHAC

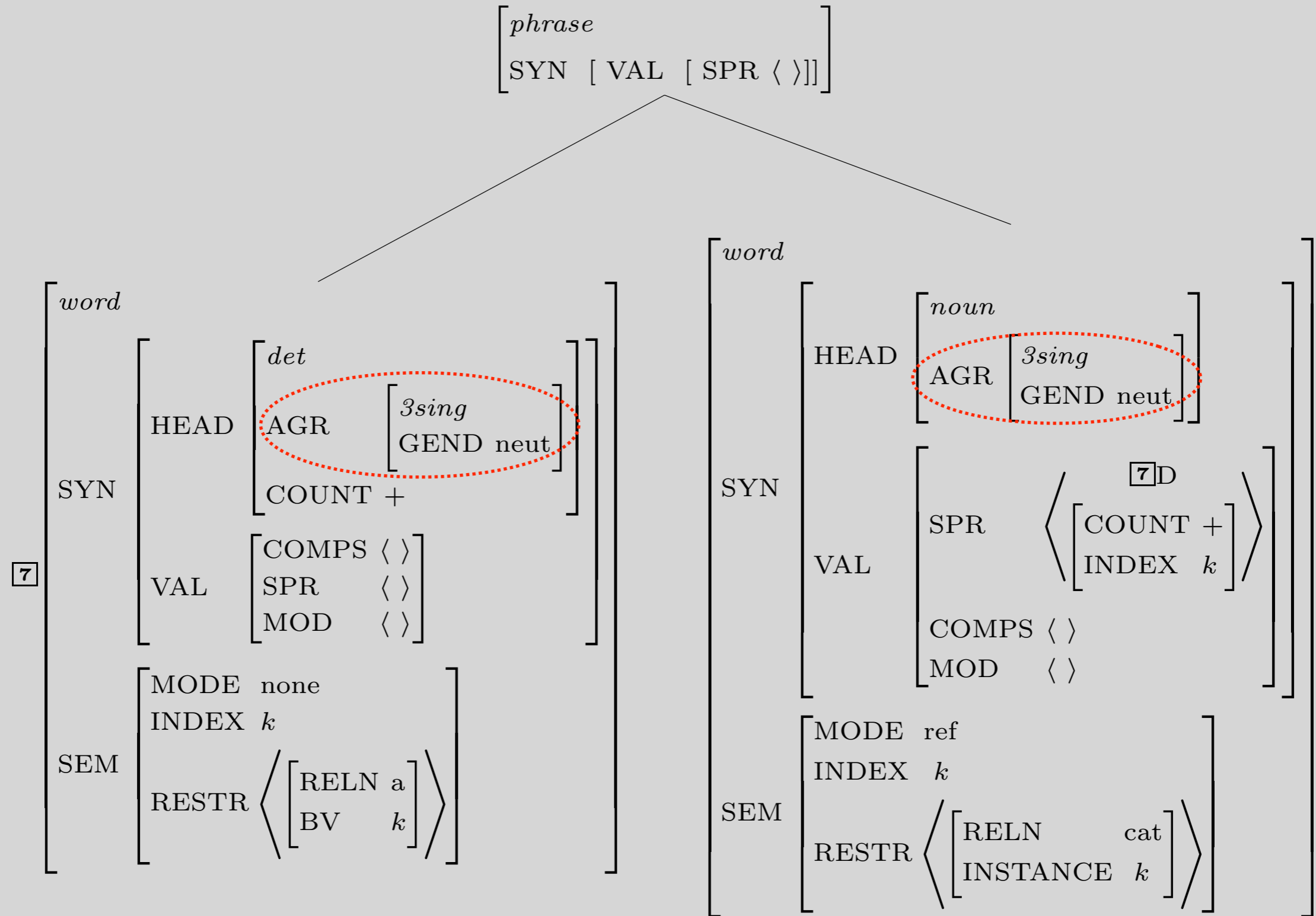

Effects of the Valence Principle

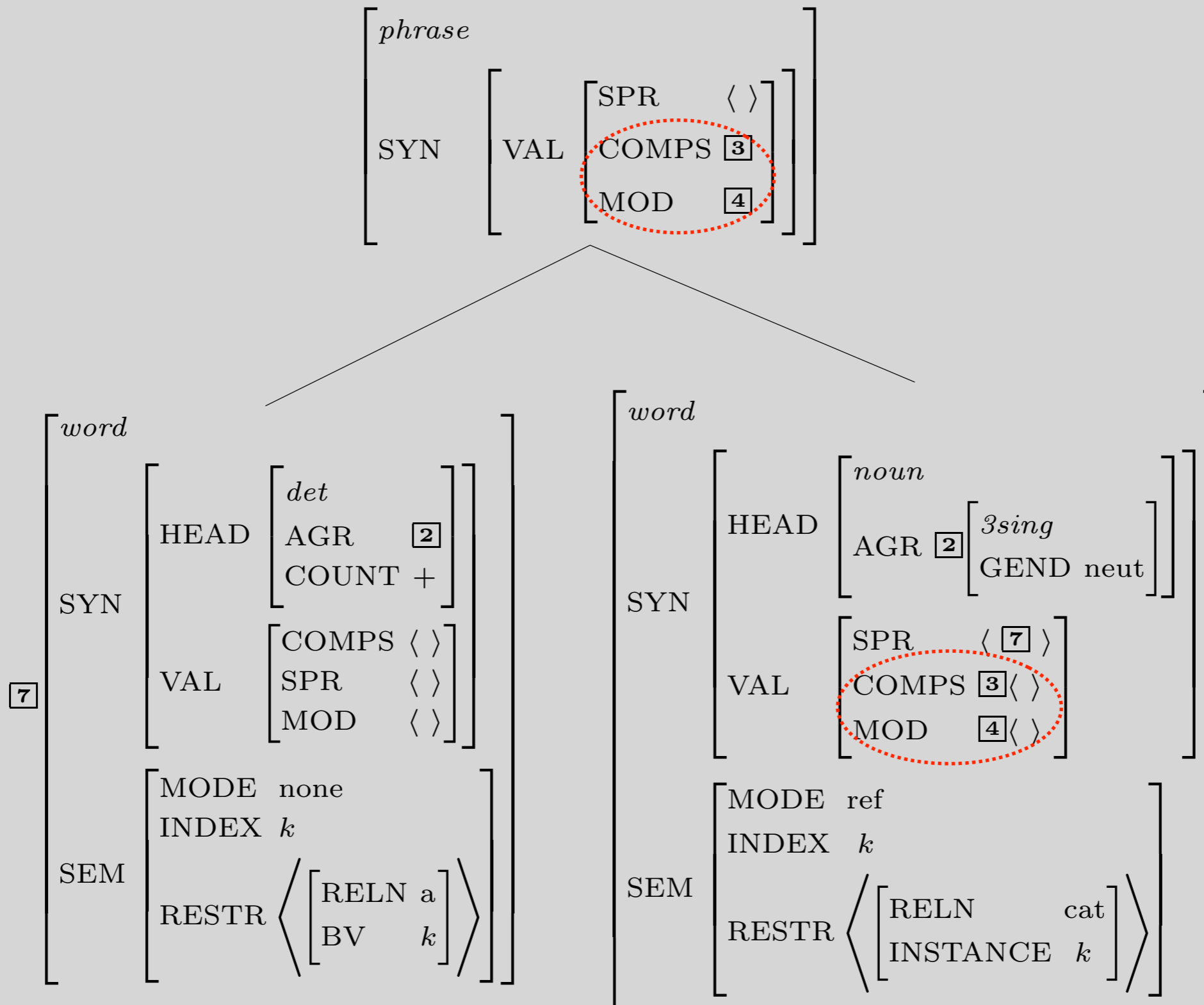

Effects of the Head Feature Principle

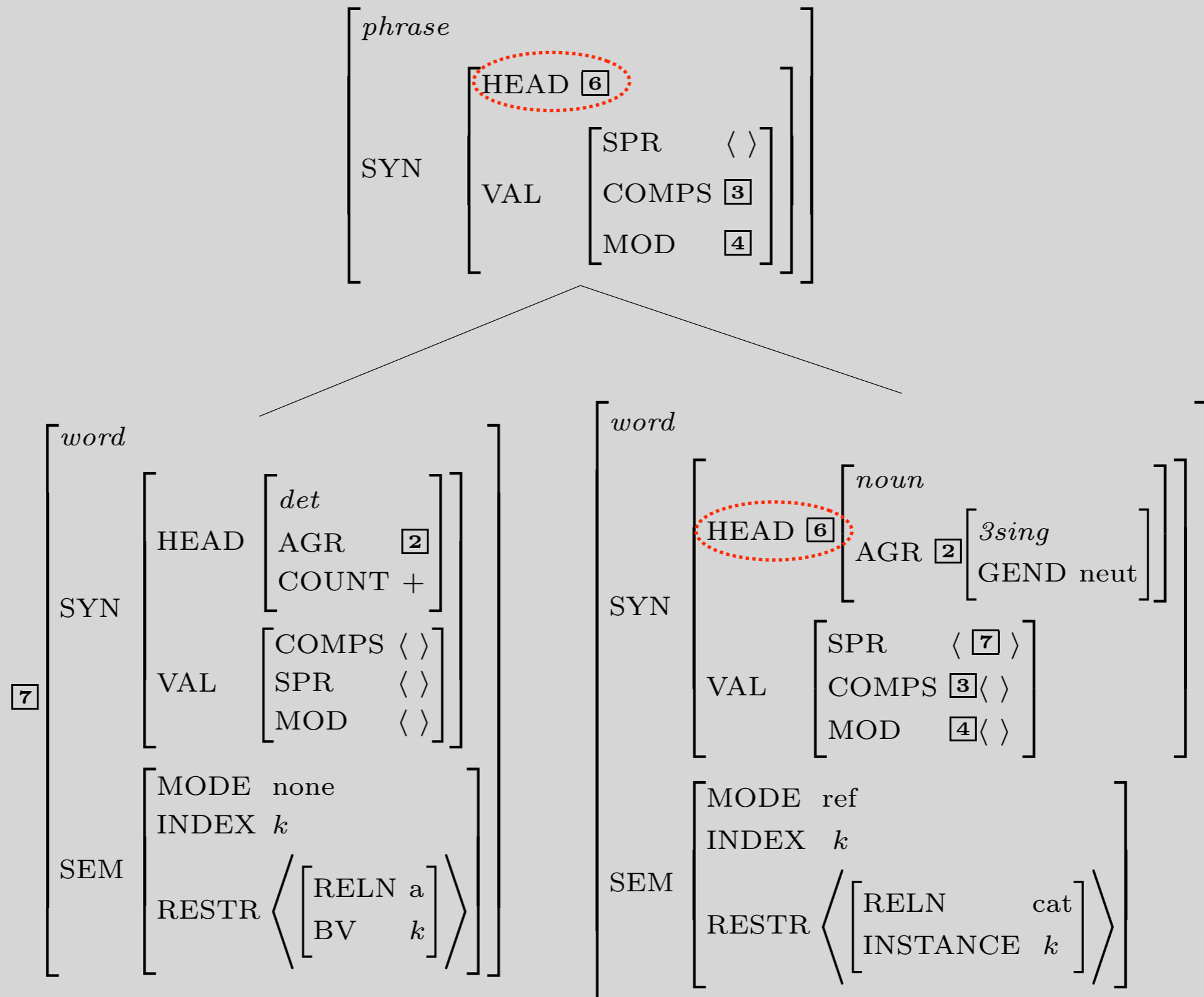

Effects of the Semantic Inheritance Principle

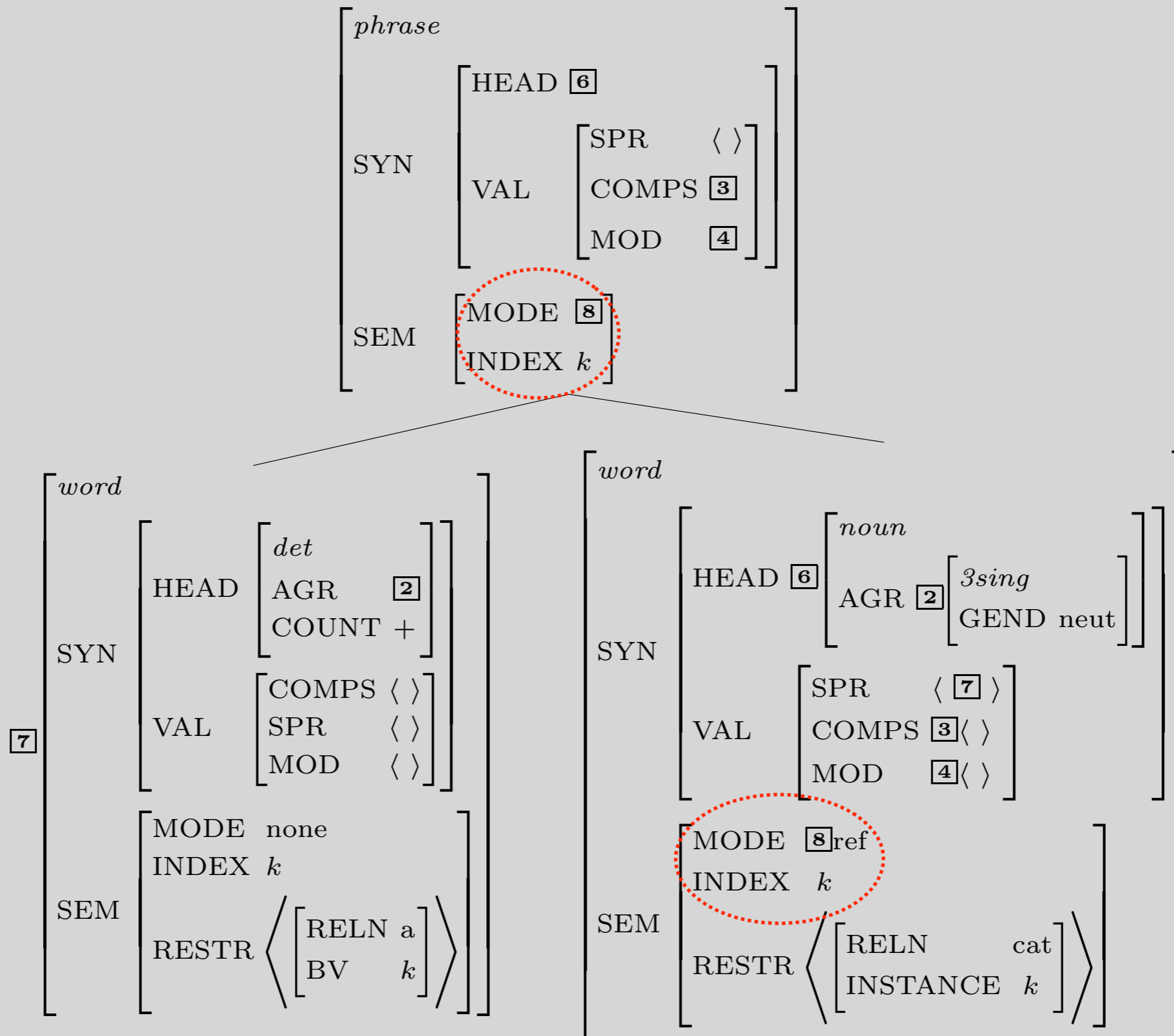

Effects of the Semantic Compositionality Principle

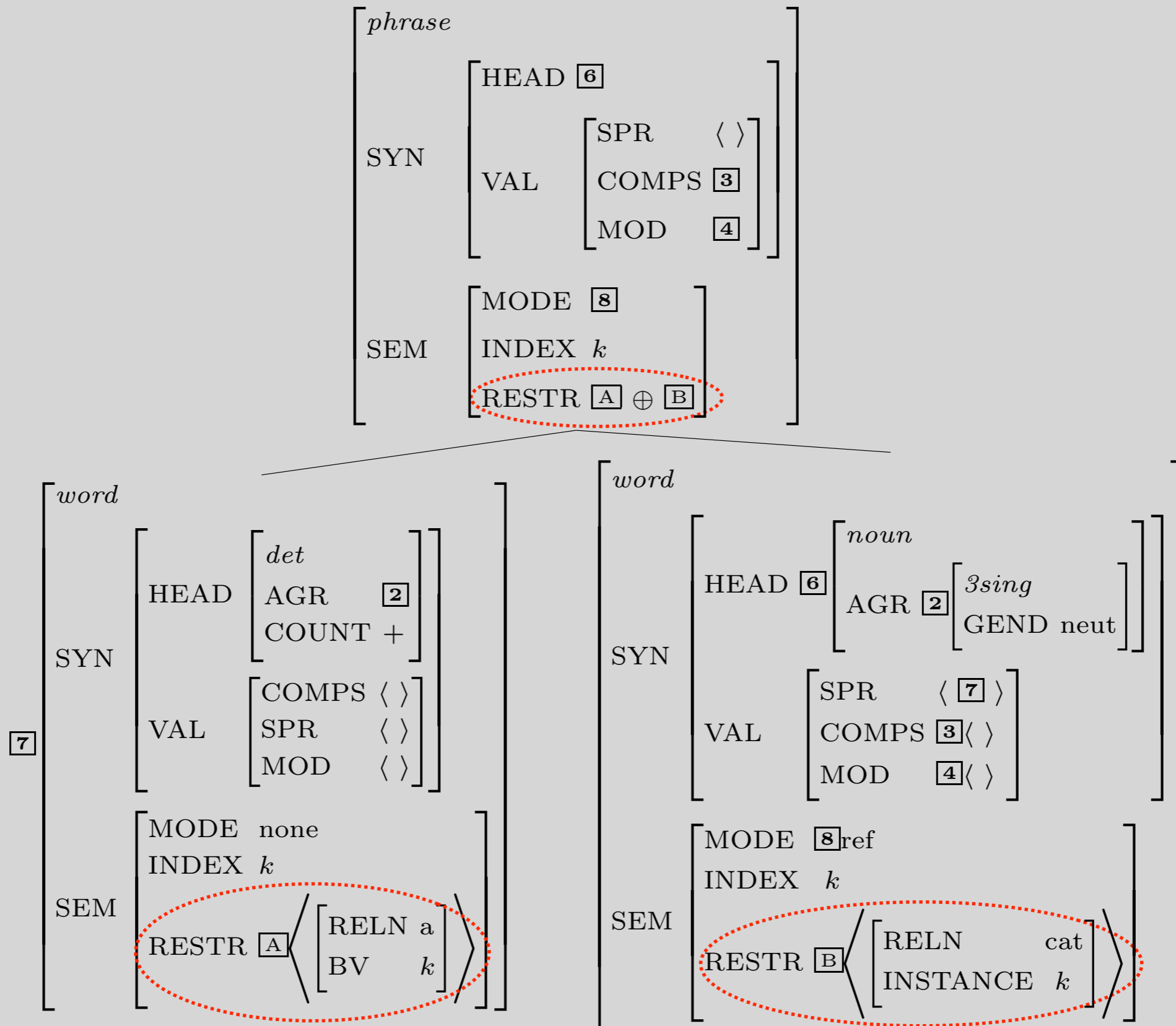

Lexical Entry for *slept*

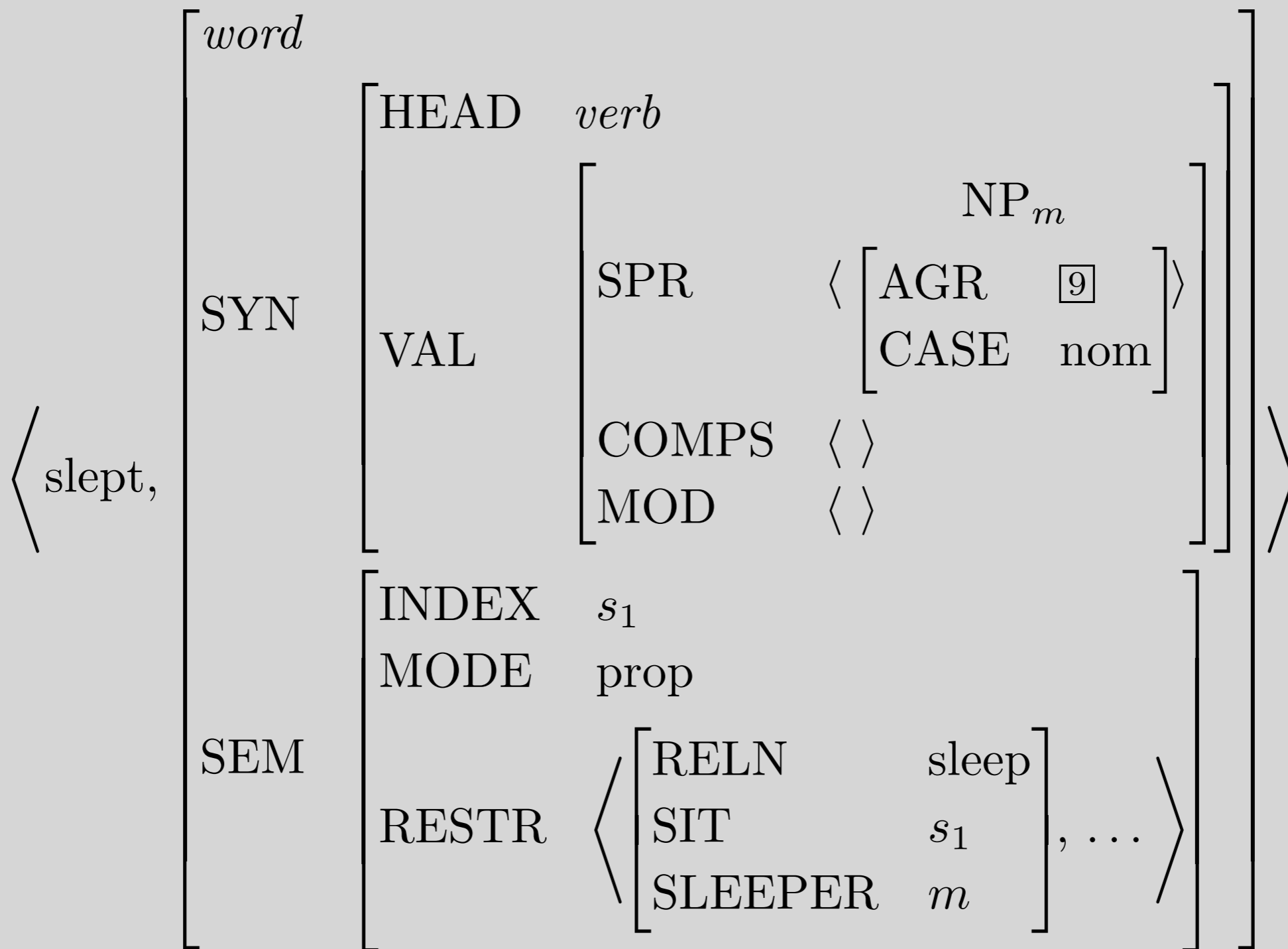

Another Head-Specifier Phrase

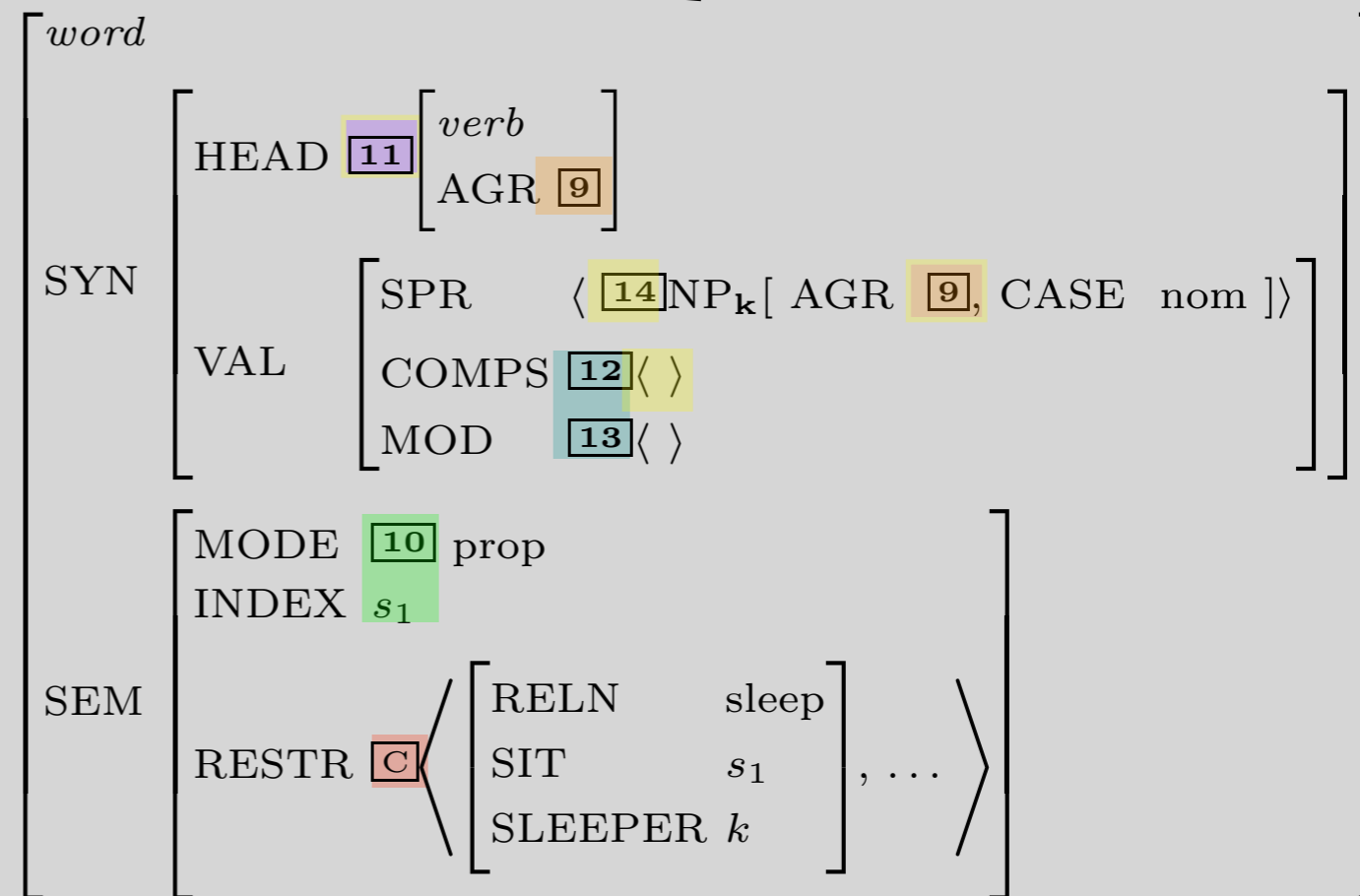
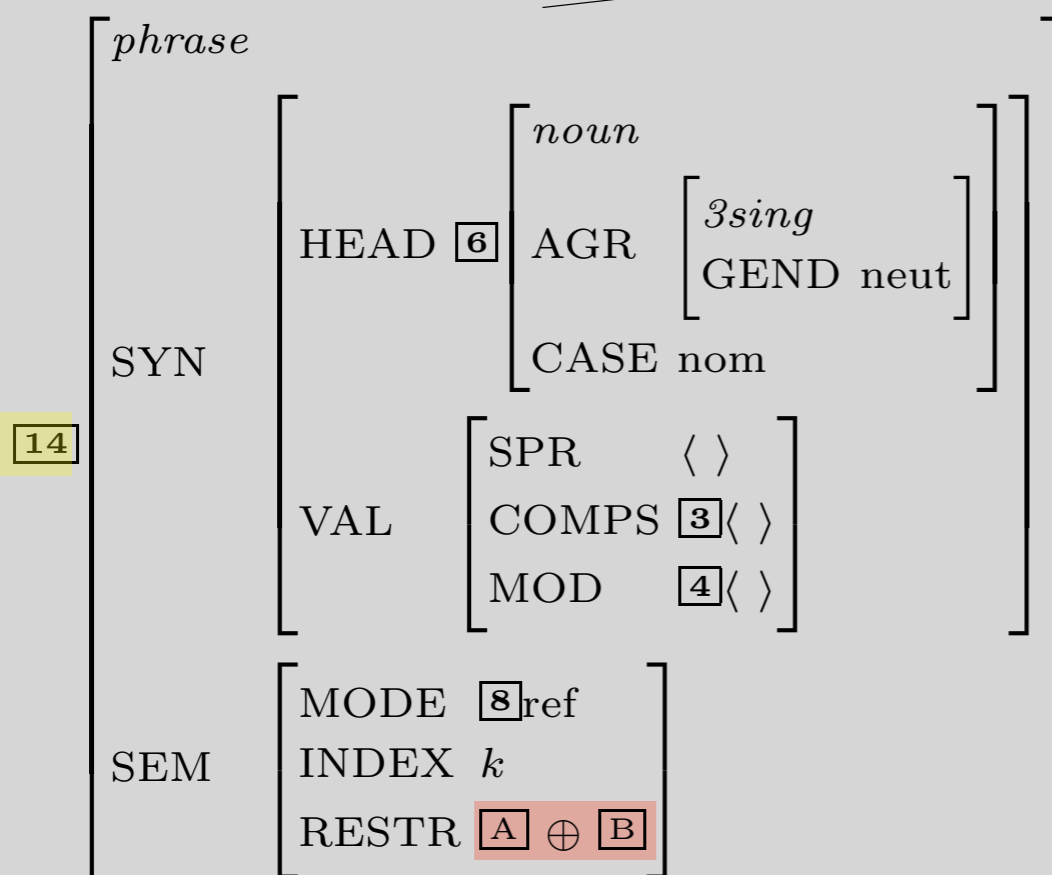
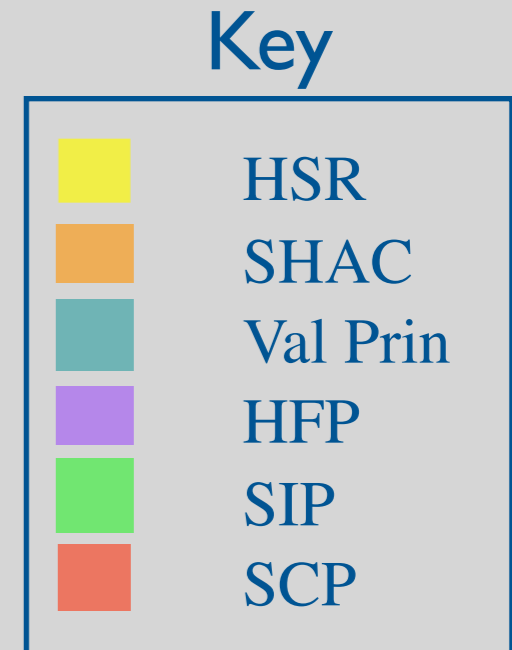
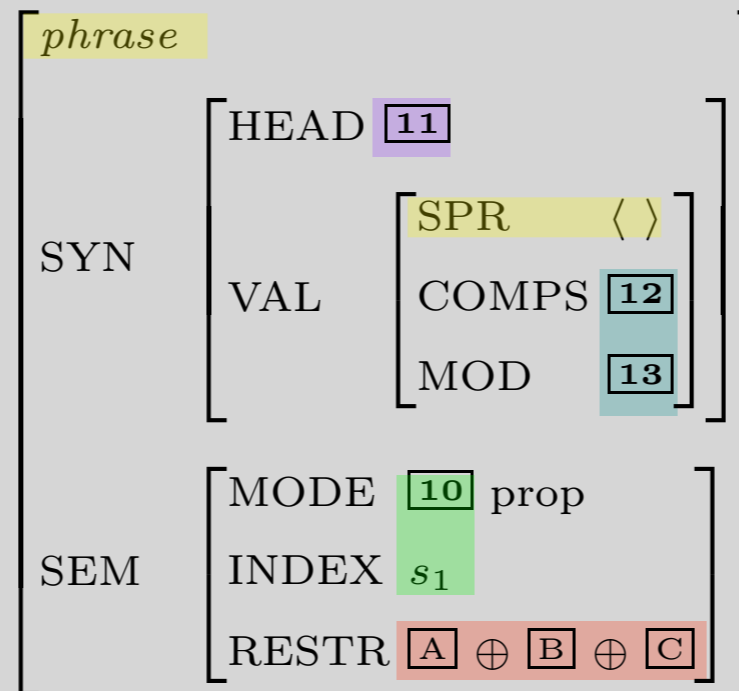

Is this description fully specified?

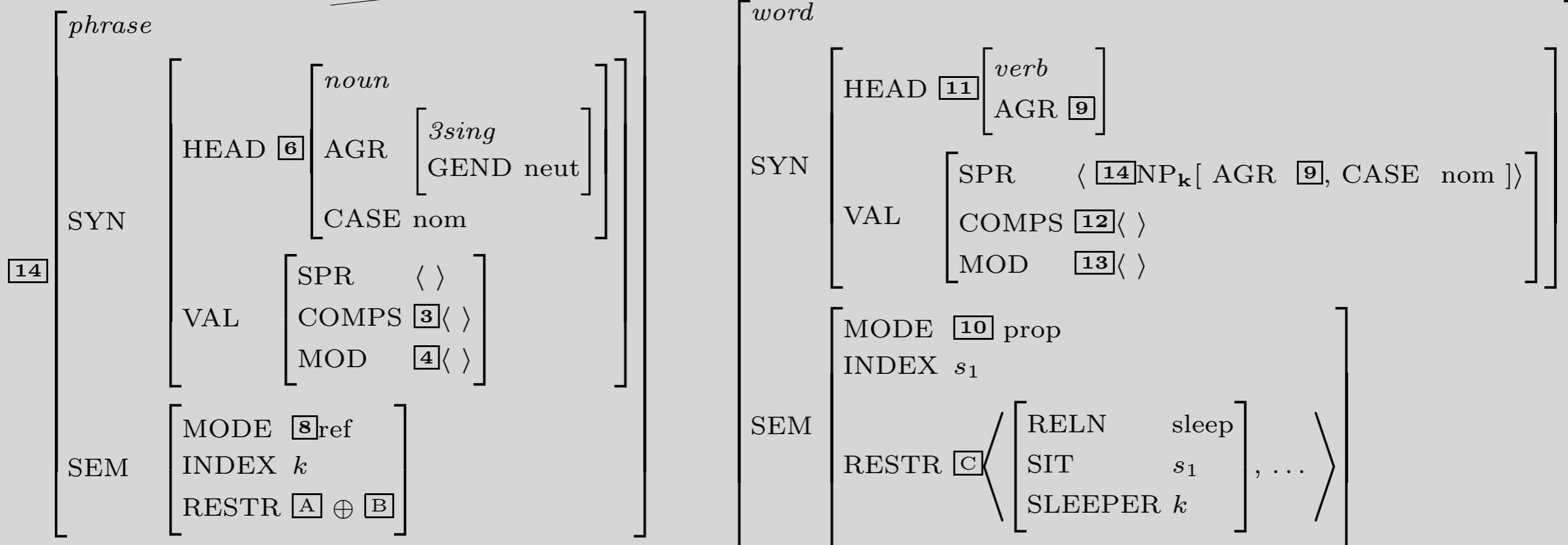
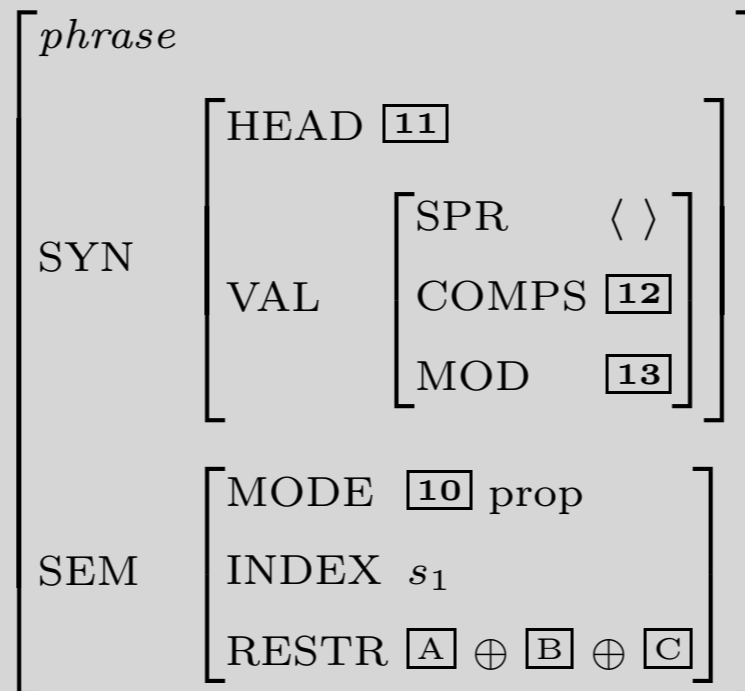

Does the top node satisfy the initial symbol?

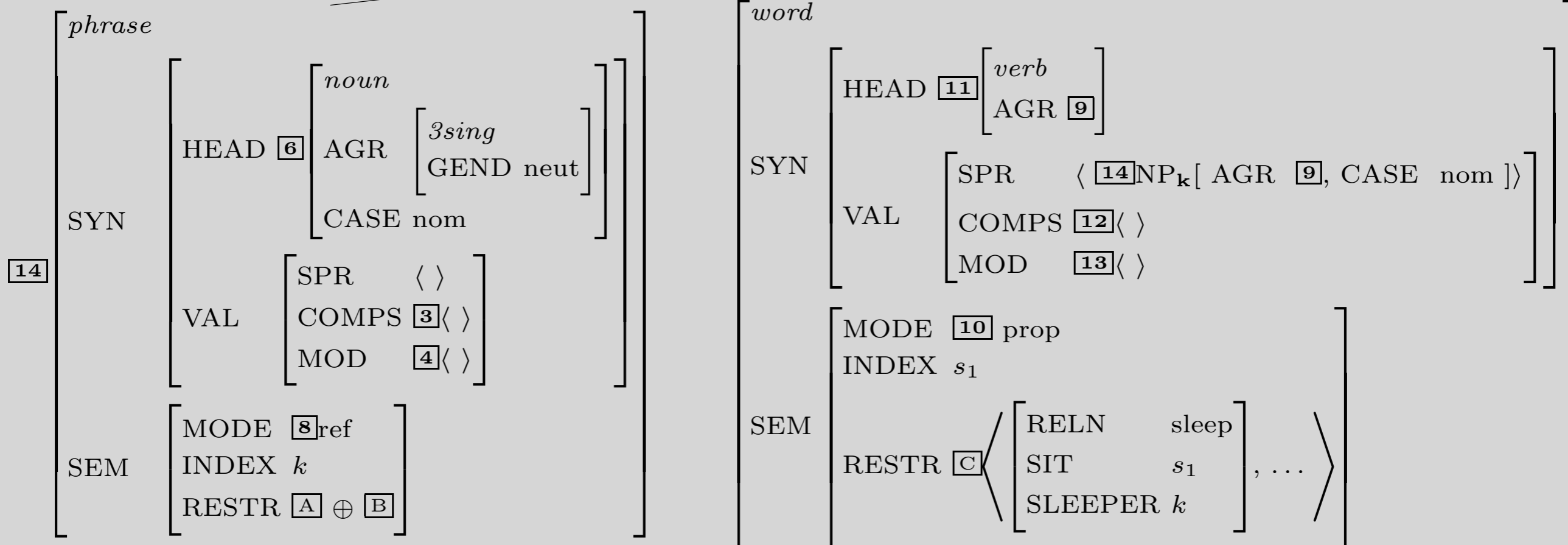
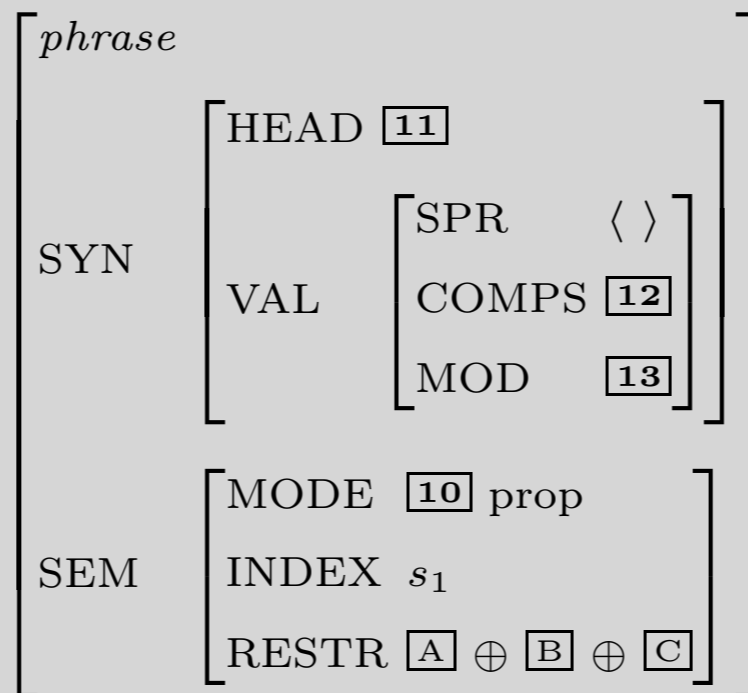

RESTR of the S node

$$\left\langle \begin{bmatrix} \text{RELN} & a \\ \text{BV} & k \end{bmatrix}, \begin{bmatrix} \text{RELN} & \text{cat} \\ \text{INST} & k \end{bmatrix}, \begin{bmatrix} \text{RELN} & \text{sleep} \\ \text{SIT} & s_1 \\ \text{SLEEPER} & k \end{bmatrix}, \dots \right\rangle$$

Another Example

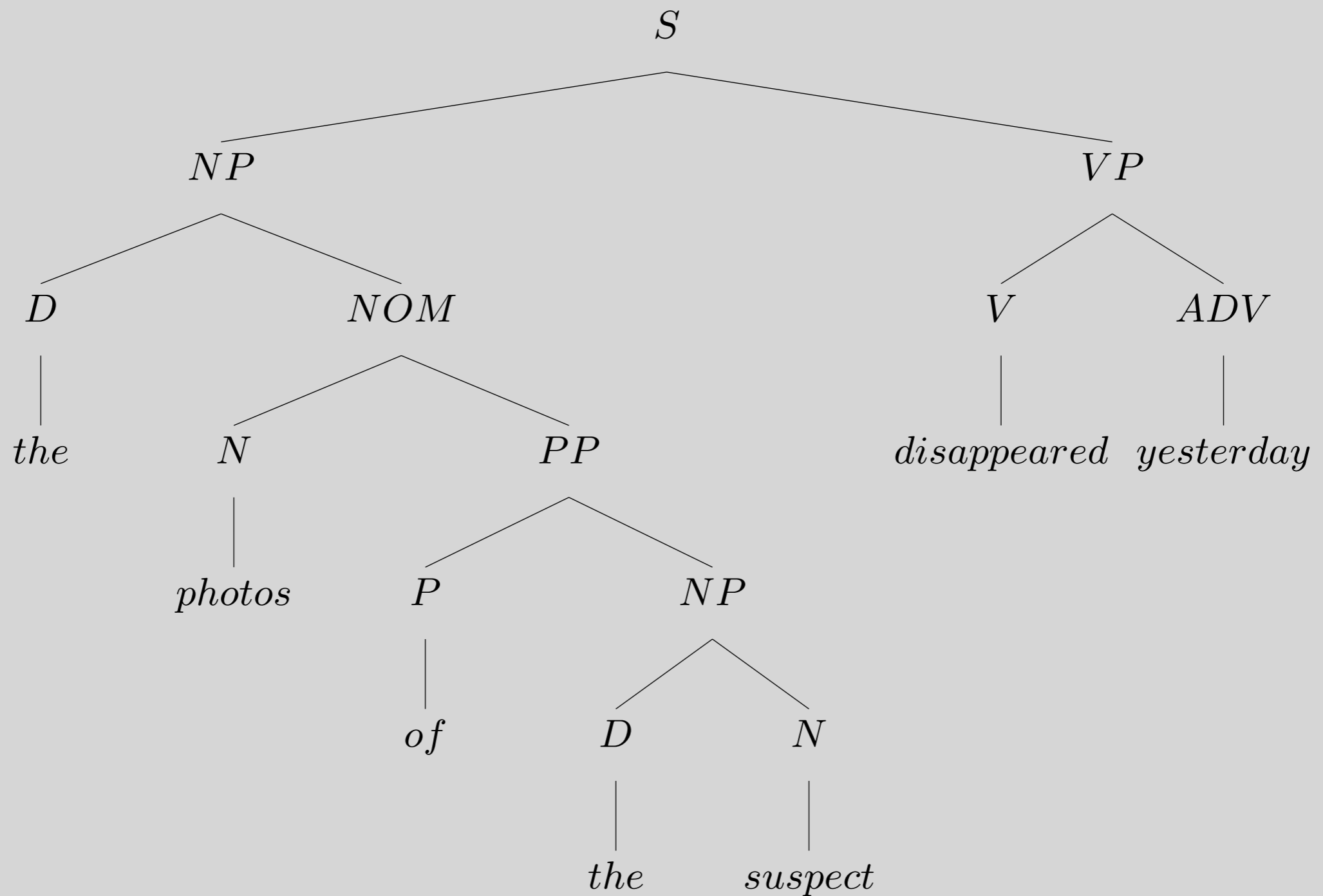

Head Features from Lexical Entries

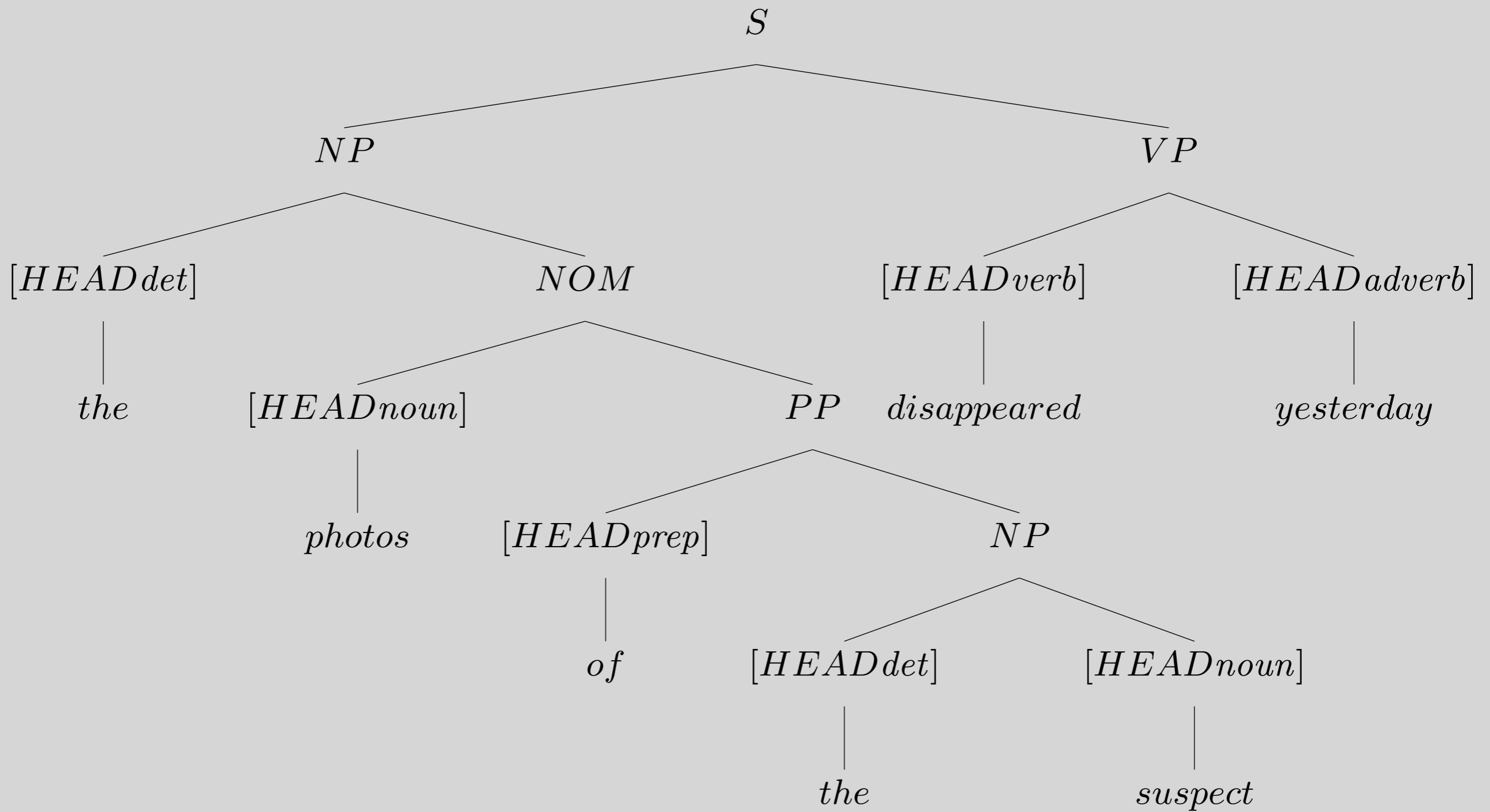

Head Features from Lexical Entries, plus HFP

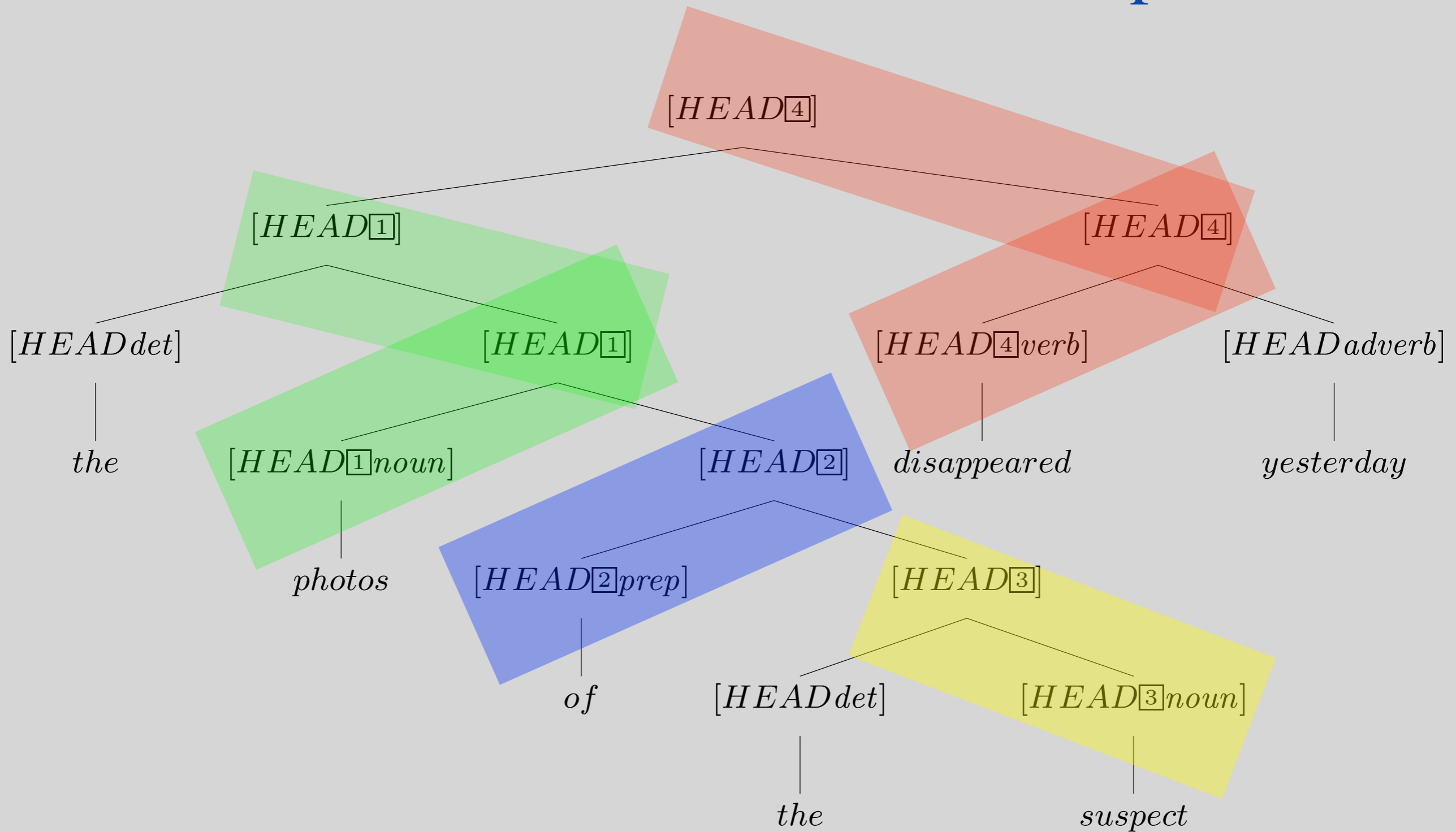

Valence Features: Lexicon, Rules, and the Valence Principle

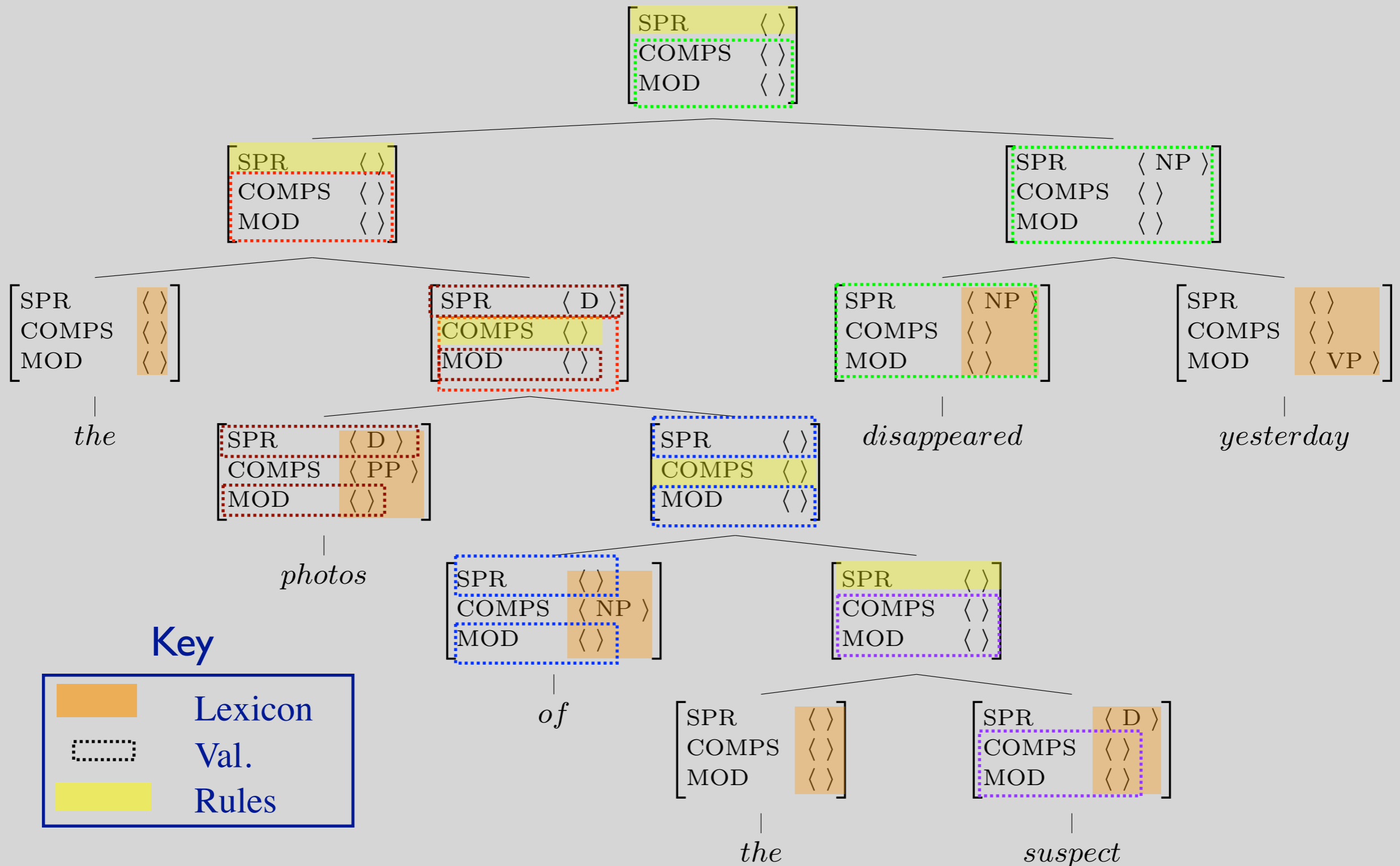

Required Identities: Grammar Rules

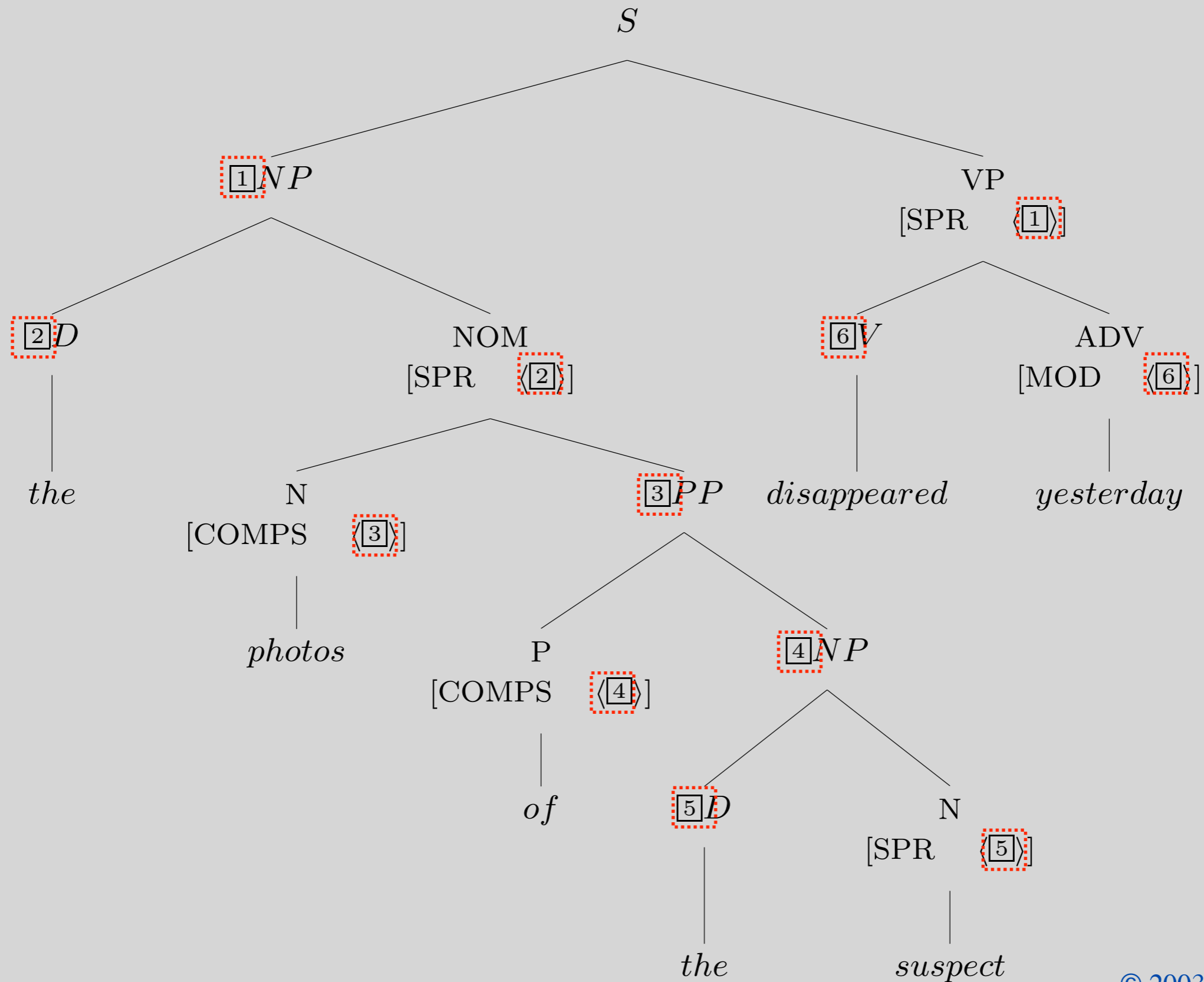

Two Semantic Features: the Lexicon & SIP

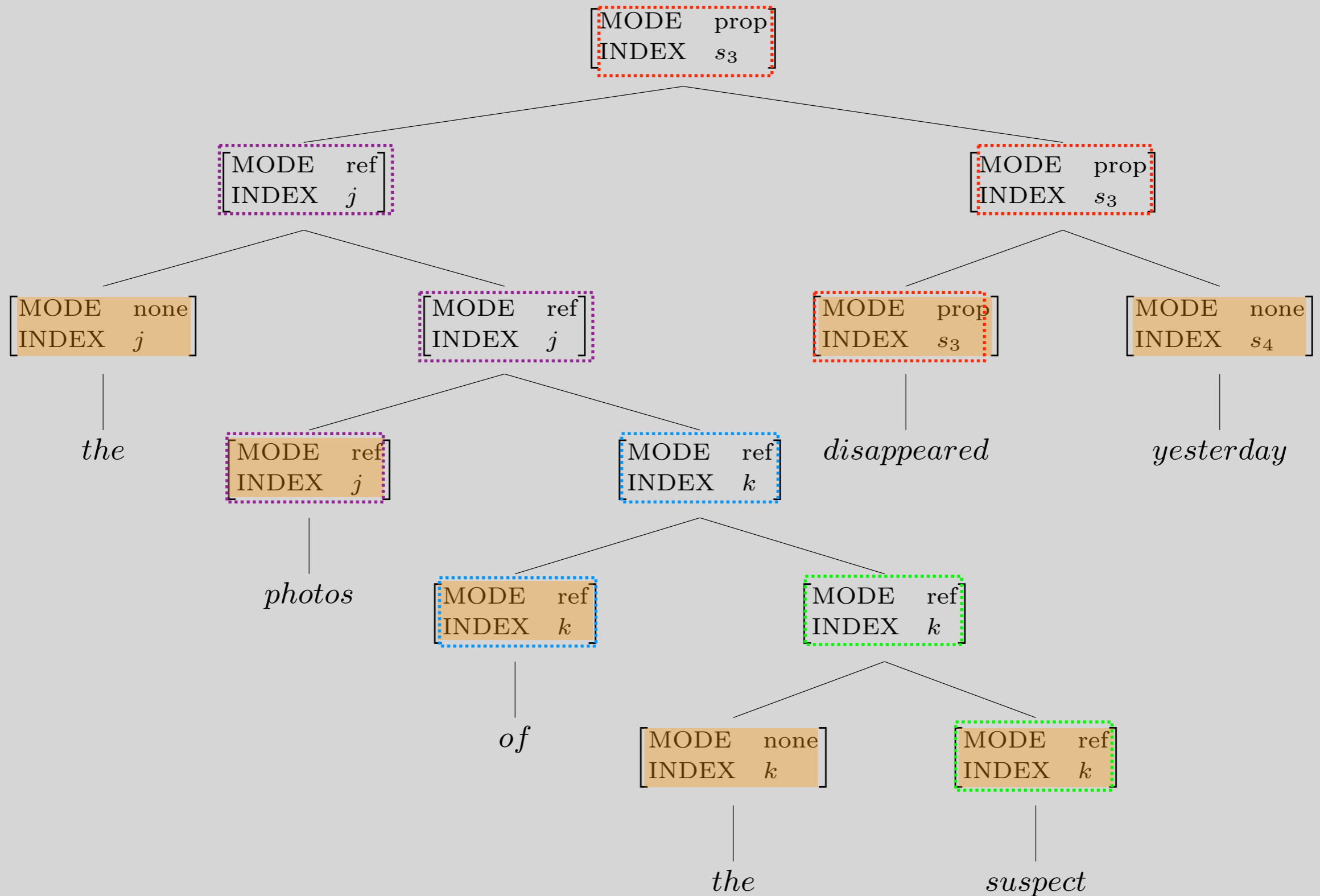

RESTR Values and the SCP

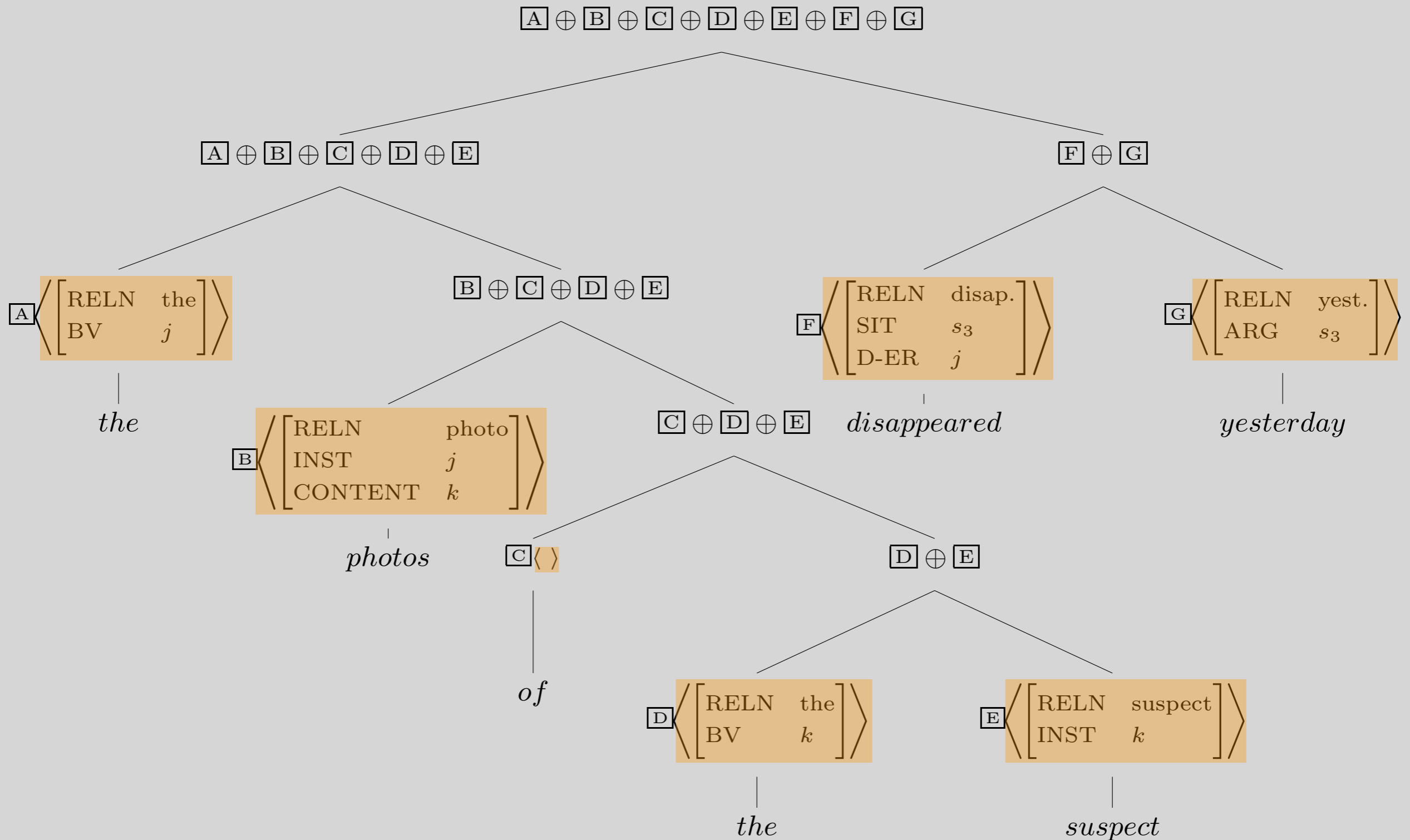

An Ungrammatical Example

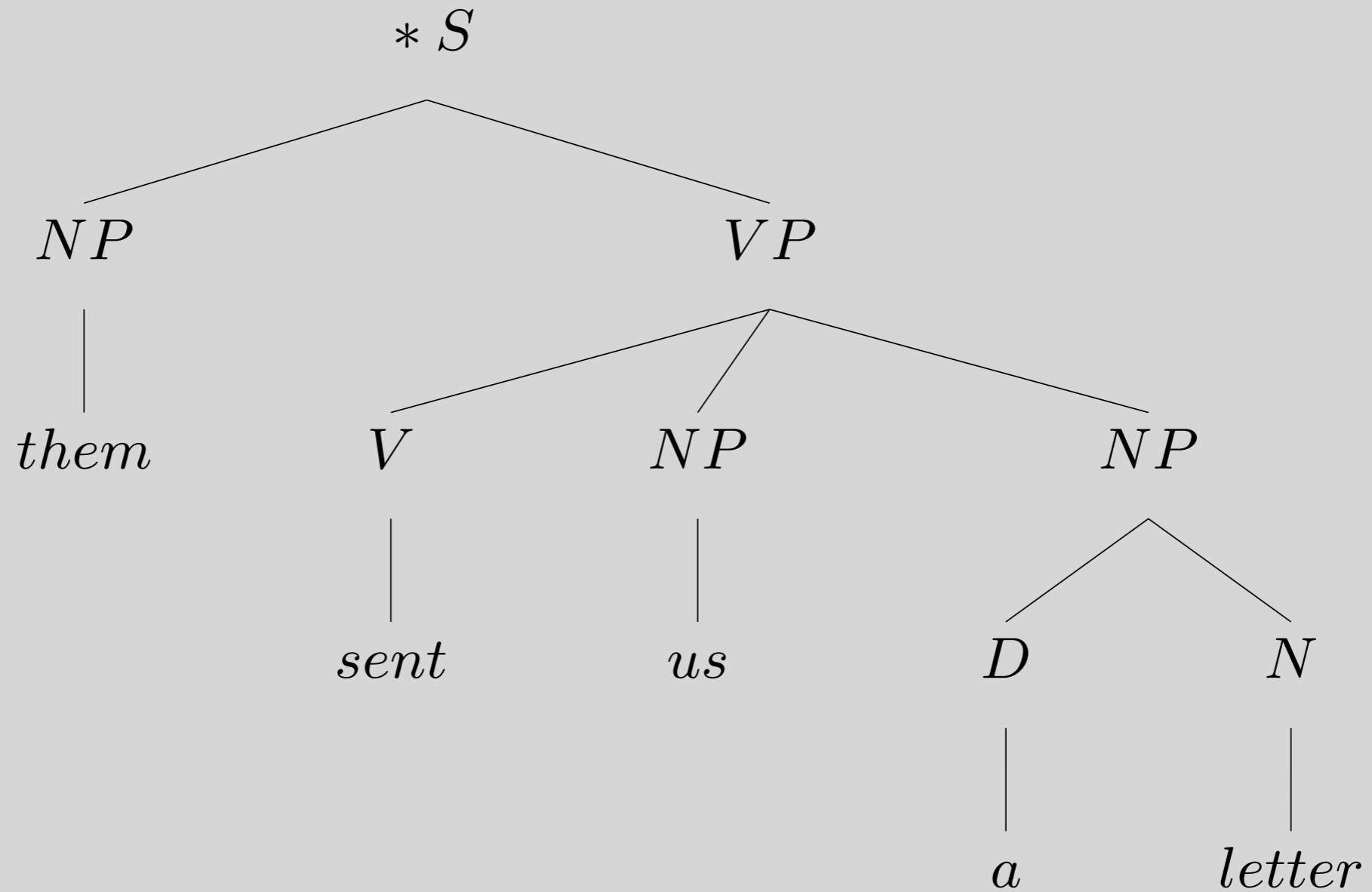

What's wrong with this sentence?

An Ungrammatical Example

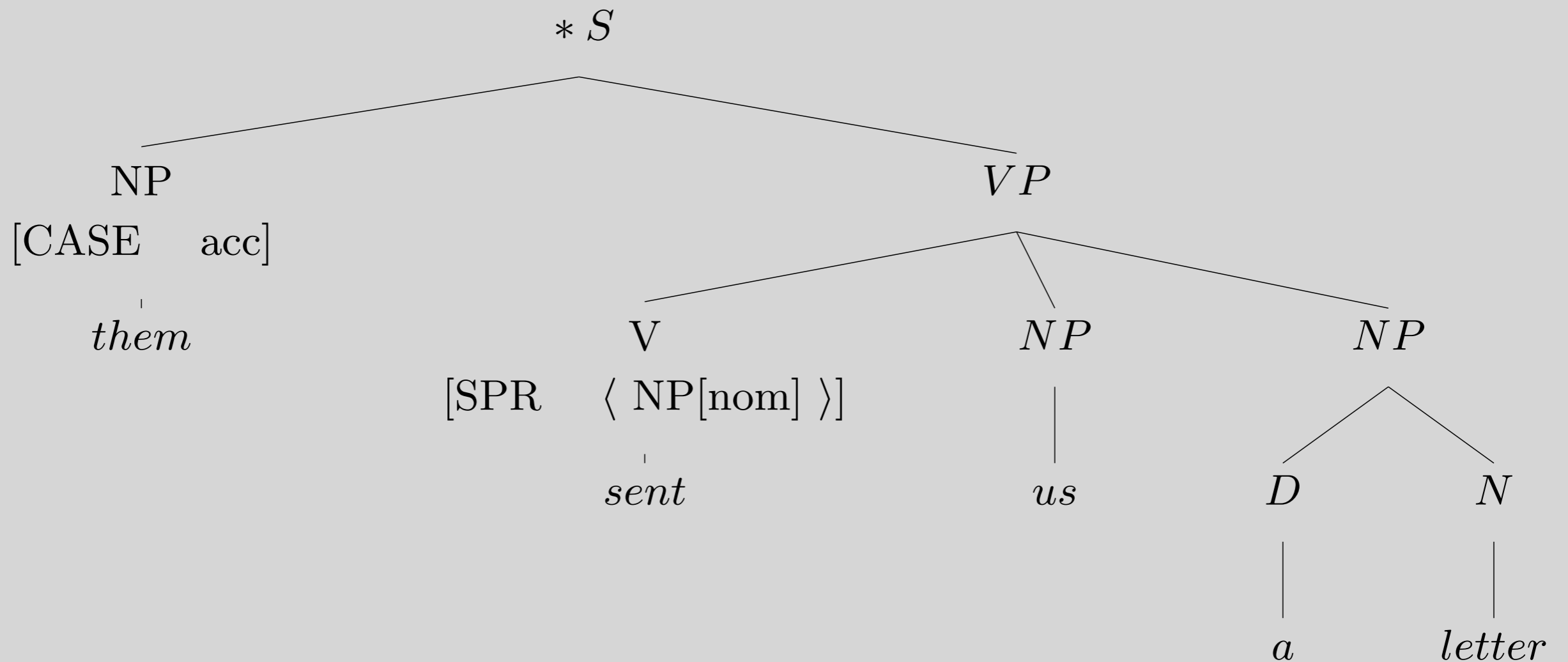

What's wrong with this sentence?

So what?

An Ungrammatical Example

The Valence Principle

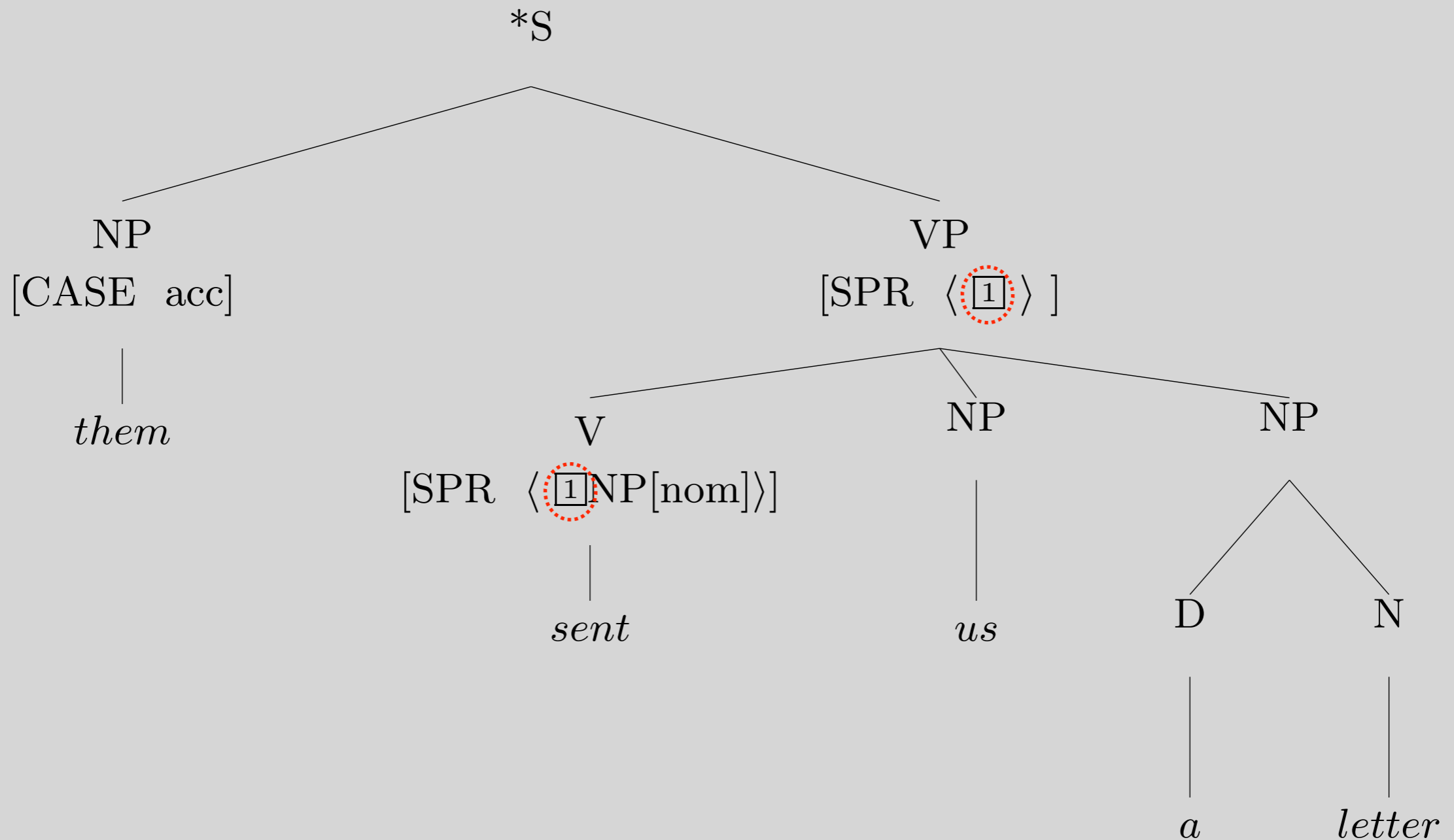

An Ungrammatical Example

Head Specifier Rule

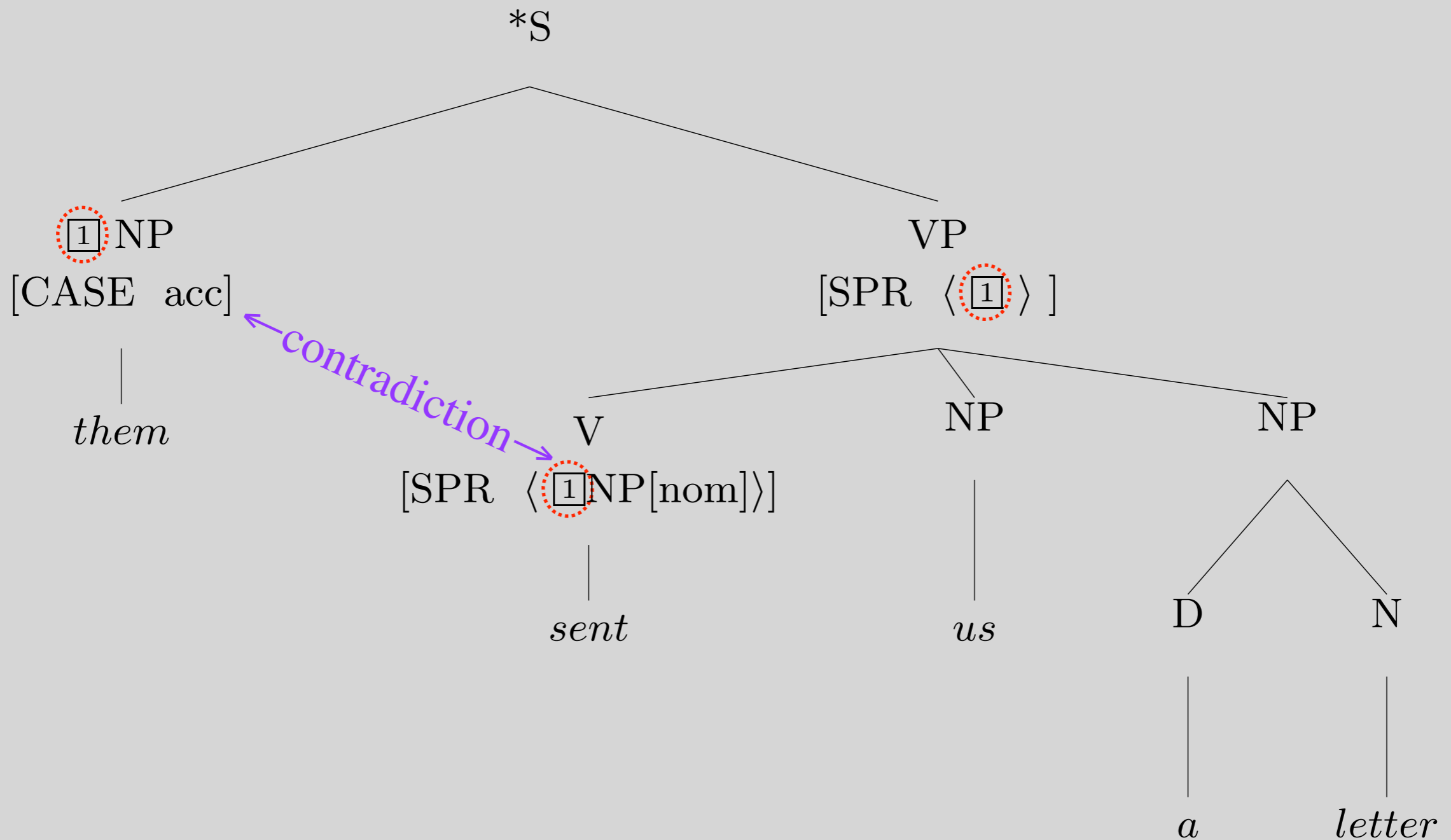

Exercise in Critical Thinking

- Our grammar has come a long way since Ch 2, as we've added ways of representing different kinds of information:
 - generalizations across categories
 - semantics
 - particular linguistic phenomena: valence, agreement, modification
- What else might we add? What facts about language are as yet unrepresented in our model?

Overview

- What we're trying to do
- The pieces of our grammar
- Two extended examples
- Reflection on what we've done, what we still have to do
- Reading questions

Reading Questions

- I have a question about the "+ in circle" symbol. When should we use that symbol and when should we use the list symbol $\langle \rangle$? Is this two symbol the same?
 - $[A] (+) [B]$
 - $\langle [1] \rangle (+) [B]$
 - $\langle [1] \rangle (+) \langle [2] \rangle$
 - BAD BAD BAD: $\langle [A] (+) [B] \rangle$

Reading Questions

- For the example "They sent us a letter" - It's clear to me why having the role for 'addressee' does not cause any problems, but I am still confused as to what the argument for including it in the entry is. Why include it if it doesn't tie to anything else? Is it essential to list it?
- How do we know how many arguments to posit in a lexical entry?

Reading Questions

- The comparison of the two interpretations for "They sent a letter to Lee" made me wonder if it's always possible to distinguish between syntactic ambiguities by means of the semantic feature structures, or are there other cases where that is not enough?
- What's up with that entry for us?

Reading Questions

- In-spite of this formalism of how syntax and semantic flows through a tree/phrase, because the RESTR values are driven by the word/lexicon itself and different words can have different values to specify these relations, doesn't this restrict the ability of the grammar to generalize? Aren't we going to end up with a grammar that is too specific to the sentence it is parsing, given that we are letting the word dictate the

Reading Questions

- "When the Head-Specifier Rule enforces this identity, it forms a link in a chain of identities: ... This chain of identities ensures that the BV of the exist predication and the INST of the letter predication are one and the same (k)." page 172-173
- Is this identity chain referring to the RESTR list? When the final RESTR list turns into something like "[RELN two, BV k] + [RELN letter, INST k, ADDRESSEE m] + ...", is the chain an idea that binds (k) to two and letter?

Reading Questions

- In the lexical entry for 'send', why can both complements have accusative case? Why don't we need something like dative case for the second complement to avoid accepting *they gave a letter us?
- Why do we bother including a CASE feature in English examples where it isn't marked? Is it to help select for the position in a sentence? For example, showing what kinds of NPs could be a complement to a prepositional phrase?

Reading Questions

- "There are infinitely many word structures that satisfy (5)". I see why it can satisfy several structures once it starts combining with COMPS, SPRS, and the list of RESTR values becomes modified, but isn't the idea of having both syntactic and semantic information in the lexical entry in precise specification of allowable contexts for this entry, therefore there should be a limit to the features it can take?

Reading Questions

- I found it really interesting that lexical entries imply an infinite amount of licensed structures. Our grammar rules allow for infinite possible structures, and now this chapter made it evident that lexical entries allow this too. It seems that this is because lexical entries involve features that specify something related to the grammar rules. That being so, I wonder if we can say that the productivity of language is due to both lexical entries and grammar rules for truly distinct reasons, or if they both boil down being the same exact source of the productivity.

Reading Questions

- I am confused about this statement, "Each rule says, in effect, that subtrees of a certain kind are sanctioned, but the rule only specifies some of the constraints that the trees that it licenses must obey," (Page 168) especially the first half. More illustration of this statement will be greatly appreciated.

Reading Questions

- Is there an equivalence between underspecification and optional components? For example in the lexical entry for letter (5), the complement indicates the word can take an optional PP. If COMPS were to be excluded from the entry would that also mean that letter can take an optional PP (or any other phrase for that matter)?

Reading Questions

- I wonder if the grammar could solve the problem of word order in languages? The RESTR list seems not to have the restrictions on the order of the complements(i.e send).

Reading Questions

- I'd like further clarification on the reasonings behind not supporting TENSE in our feature structures. It feels like such a significant feature that leaving it out is confusing. Especially since this current chapter even shows a certain difference between 'send' and 'sent'. They're marked differently, but not in ways one would normally suspect.

Reading Questions

- I had some trouble understanding why the COMPS list was different between in the lexical entries for "sent" and "send" on pages 175 and 183. I understand that these values are appropriate for the respective trees these verbs are placed in, but my understanding was that lexical entries are underspecified and then filled in when placed as part of the tree. If the actual lexical entries are different in the abstract (unrelated to the trees they're placed in), I'm hoping to get some clarification on why. It tentatively seems like they could be used much the same way.

Reading Questions

- "By far the richest source of information in this factorization is the lexicon." Does this statement hold for languages (unlike English) that have rich inflectional, derivational, and case structures? Or are these other systems inherently present in our model of the lexicon?

Reading Questions

- Is BV exclusive to determiners or does it apply to all specifiers? The purpose of BV is just to show the word's connection to the head, correct?
- What is the difference between INST and INDEX?

Reading Questions

- How does our system enforce semantic acceptability for sentences that are syntactically grammatical? For example, a sentence like 'I drank the pizza' is syntactically sound, but it sets off some semantic alarms. Is this determined in the lexicon? In other words, do we need to have a feature for everything that determines if something is drinkable or not? If this is the case, it seems like we could keep on breaking down words into finer and finer detail endlessly.

Reading Questions

- Would we create entirely new grammars based on the usage contexts and situations? Two situations I can think of are newspaper headlines, which often eliminate determiners, and works of fiction, where we can relax semantic constraints for certain words. If so, would such grammars have a lexicon that only includes words applicable to the situation at hand?

Reading Questions

- All the examples of lexical entries that we've been given, if I'm not mistaken, are for words. Is it possible to have lexical entries for phrases or expressions? I imagine those would look like mother phrases in trees as in (10). If not, why bother specifying 'word' in each lexical entry?

Reading Questions

- 'we moved more and more syntactic information out of grammar rules and into the lexicon'. But since we have a large lexicon with many groups of similar entries now, can we just categorise the lexicon entries with, say, a type hierarchy that includes type *verb-pl*, *noun-proper* and so on?

Reading Questions

- In practice, are there situations where it would make sense to draw these trees from the top-down, rather than bottom-up?

Reading Questions

- Do we have to understand the squiggly bits in 6.3?
- \Rightarrow 6.3.5 and 6.3.6 only.