

# Morphotactics in the Matrix

## Morphotactic & lexical inference

---

Ling 567

Jan 18, 2022

# Overview

---

- Morphotactics in the Grammar Matrix
- Matrix-ODIN Morphology (MOM system)
- Lab 3: Which phenomena?
- Look-ahead:

# Morphotactics: Basic concepts

---

- Position class: A supertype to lexical rules which fit in the same slot
- Lexical rule type: *lex-rule* and its subtypes, all have DTR feature
- Lexical rule instance: A grammar entity (manipulatable by the LKB) which inherits from a lexical rule type and specifies a spelling change (including no change).
- Forbids constraint: A specification in the customization system stating that a stem lexical rule type (including a position class) cannot co-occur with another lexical rule type, instance, pc or stem.
- Requires constraint: A specification in the customization system stating that a stem lexical rule type (including a position class) must co-occur with another lexical rule type, instance, pc or stem.

# Position classes, inputs and lexical rule hierarchies

---

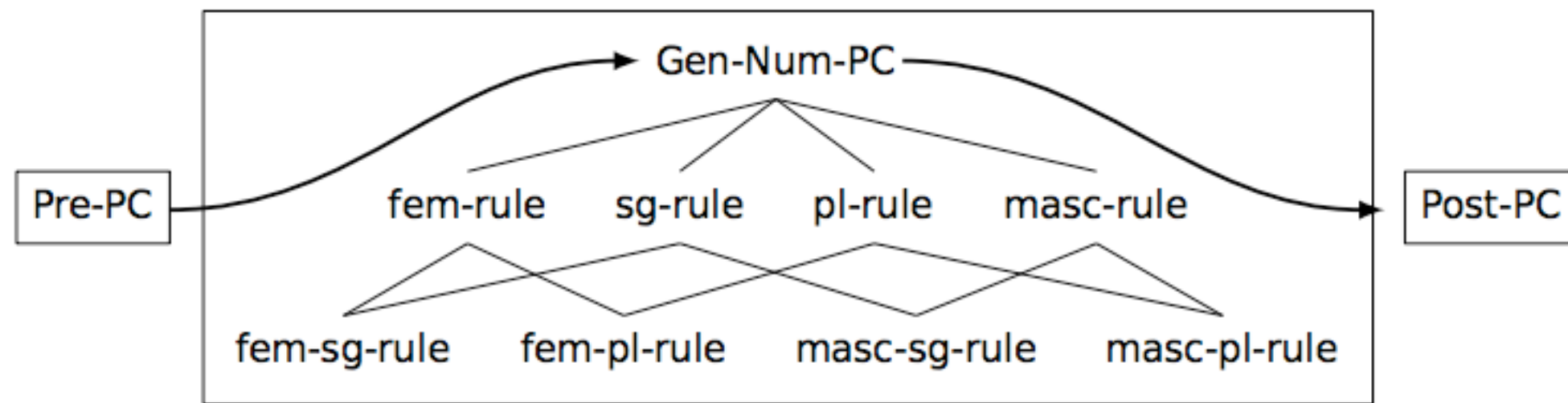

**Figure 9:** Example lexical rule type hierarchy in a position class

(Goodman 2013)

# To define a position class

---

- Required:
  - Whether or not it is obligatory
  - Possible inputs and prefix/suffix
    - = position in the string
- Optional:
  - Requires/forbids constraints

# To define a lex rule type

---

- Required
  - Nothing (though defaults fill in)
- Optional
  - Name
  - Supertype (if it doesn't inherit directly from its position class)
  - Feature/value pairs (optional, but this is usually the point!)
  - Requires/forbids constraints

# To define a lex rule instance

---

- Required
  - Affix v. no affix
  - Spelling for affix
- Optional
  - Nothing

# tdl files

---

- matrix.tdl: Supertypes for lex-rules, which handle the copying up of everything you're not changing
- my\_language.tdl: Position classes and lex rule types defined through the customization system; features for inside INFLECTED
- lrules.tdl: Instances for non-spelling-changing lex rules (zero morphemes)
- irules.tdl: Instances for spelling-changing lex rules



# Handling of morphotactics

---

- Rule order handled through super types and typing the DTR feature
- Requires/forbids through the INFLECTED feature

```
num-lex-rule-super := add-only-no-ccont-rule &
  [ INFLECTED [ NUM-FLAG +,
                PERNUMTENSE-FLAG #pernumtense ],
    DTR common-noun-lex &
    [ INFLECTED.PERNUMTENSE-FLAG #pernumtense ] ].
```

# Rule inputs in choices files

---

- arp

```
section=morphology
```

```
  noun-pc1_name=noun-pc1
```

```
  noun-pc1_order=prefix
```

```
  noun-pc1_inputs=noun3
```

```
    noun-pc1_lrt1_name=noun-pc1_lrt1
```

```
      noun-pc1_lrt1_lr11_inflecting=yes
```

```
      noun-pc1_lrt1_lr11_orth=3ii-
```

```
noun-pc1-lex-rule-super := add-only-no-ccont-rule &  
infl-lex-rule &
```

```
  [ INFLECTED #infl,
```

```
    DTR noun3-noun-lex &
```

```
      [ INFLECTED #infl ] ] .
```

```
noun-pc19_inputs=noun-pc4, noun8, noun-pc21, noun-pc22,  
noun57, noun292, noun293, noun294, noun295, noun296, noun297,  
noun298, noun299, noun300, noun301, noun302, noun304  
noun-pc19_lrt1_name=noun-pc19_lrt1  
noun-pc19_lrt1_lril_inflecting=yes  
noun-pc19_lrt1_lril_orth=he-  
  
noun-pc19-lex-rule-super := add-only-no-ccont-rule & infl-lex-  
rule & noun-pc75-rule-dtr &  
[ INFLECTED #infl,  
DTR noun-pc19-rule-dtr &  
[ INFLECTED #infl ] ].  
  
noun-pc4-lex-rule-super := add-only-no-ccont-rule & infl-lex-  
rule & noun-pc19-rule-dtr & noun-pc75-rule-dtr &  
[ INFLECTED #infl,  
DTR noun-pc4-or-noun-pc44-or-noun-pc6-rule-dtr &  
[ INFLECTED #infl ] ].
```

# Matrix-ODIN Morphology (MOM) system

(Wax et al 2012, Wax 2014, Zamaraeva et al 2017, 2019, Howell 2020)

---

- Read in IGT, identify verbs (resp. nouns), identify roots
- Observe root-affix co-occurrences
- Merge affixes with shared inputs above threshold into position classes
- Previously: assumed all words of a given POS were in one class; currently iterate between merging words into classes (constrained by valence) and merging affixes into PCs
- Previously: all lexical rules are optional, no non-inflecting rules
- Currently: posit non-inflecting rules for certain types of glosses & make associated position classes obligatory

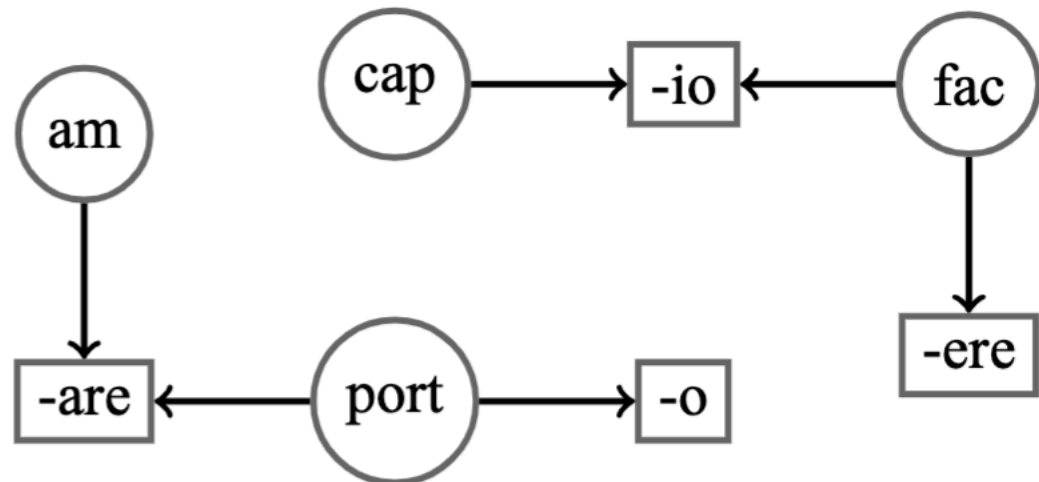

Figure 1: Sample graph MOM will initially build on the example training data consisting of Latin verbs *am-are* ('to love'), *port-are* ('to carry'), *port-o* ('I carry'), *cap-io* ('I take'), *fac-io* ('I do'), and *fac-ere* ('to do').

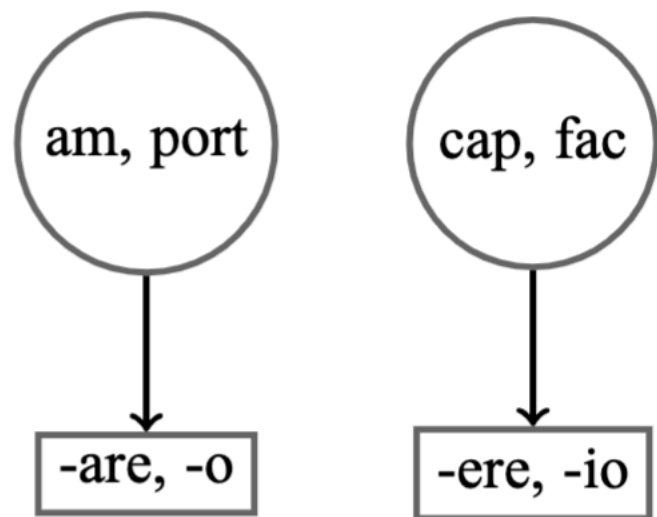

Figure 2: Sample MOM output, after compressing the graph in Figure 1 with a 50% overlap value.

Figure from  
Zamareva et al 2019

# Lab 2 grading notes

---

- Please be sure to include: grammar, testsuite.txt, tsdb/home, tsdb/skeletons, write up
- Write ups should include specific choices (later tdl) pasted in, in addition to the prose descriptions
- Write ups should include IGT (not just strings or strings + translations)
- Detailed comments by email

# Choosing phenomena for Lab 3

---

- Additional phenomena this week are only about testsuite extension, because primary development work is on morphotactics
- Testsuite development this week will serve choices & tdl modifications in future weeks
- Testsuite development this week can also illustrate existing functionality of choices files
- To the extent that we can coordinate on phenomena, that is desirable, but not all languages evince all phenomena

# List of phenomena

---

- <http://courses.washington.edu/ling567/testsuites.html#phenomena>
  - [Basic Word Order](#)
  - [Pronouns](#)
  - [The Rest of the NP](#)
  - [Argument Optionality](#)
  - [Agreement](#)
  - [Case](#)
  - [Negation](#)
  - [Matrix yes-no questions](#)
  - [Embedded complement clauses](#)
  - [Adverbial clausal modifiers](#)
  - [Modals](#)
  - [Coordination](#)
  - [Agreement in NP Coordination](#)
  - [Tense/aspect](#)
  - [Demonstratives/definiteness](#)
  - [Possessives](#)
  - [Attributive adjectives](#)
  - [Adverbs](#)
  - [Non-verbal predicates](#)
  - [Information Structure](#)
  - [Matrix wh questions](#)
  - [Valence-Changing Lexical Rules](#)
  - [Evidentials](#)



# MMT sentences

---

Dogs sleep

Dogs chase cars

I chase you

Dogs eat

The dogs dont chase cars

I think that you know that dogs chase cars

I ask whether you know that dogs chase cars

Cats and dogs chase cars

Dogs chase cars and cats chase dogs

Cats chase dogs and sleep

Do cats chase dogs

Hungry dogs eat

Dogs in the park eat

Dogs eat in the park

The dogs are hungry

The dogs are in the park

The dogs are the cats

The dog s car sleeps

My dogs sleep

Who sleeps

What do the dogs chase

What do you think the dogs chase

Who asked what the dogs chase

I asked what the dogs chased

The dog sleeps because the cat sleeps

The dog sleeps after the cat sleeps

I can eat glass

It doesnt hurt me