

# **Cytochrome P450 Mechanism B**

## **Major Types of P450 oxidation Reactions**

A look at the impressive oxidation reactions resume of P450 enzymes. In most cases the mechanism shown is the consensus mechanism of the reaction. Most of the reactions can be explained through Compound I catalysis but sometimes Cmp 0 can also be invoked

See: F. Peter Guengerich and Andrew W. Munro, Unusual Cytochrome P450 Enzymes and Reactions 2013, JBC VOL. 288, NO. 24, pp. 17065–17073

# P450 cycle (again) showing the different resonance forms of the perferryl species

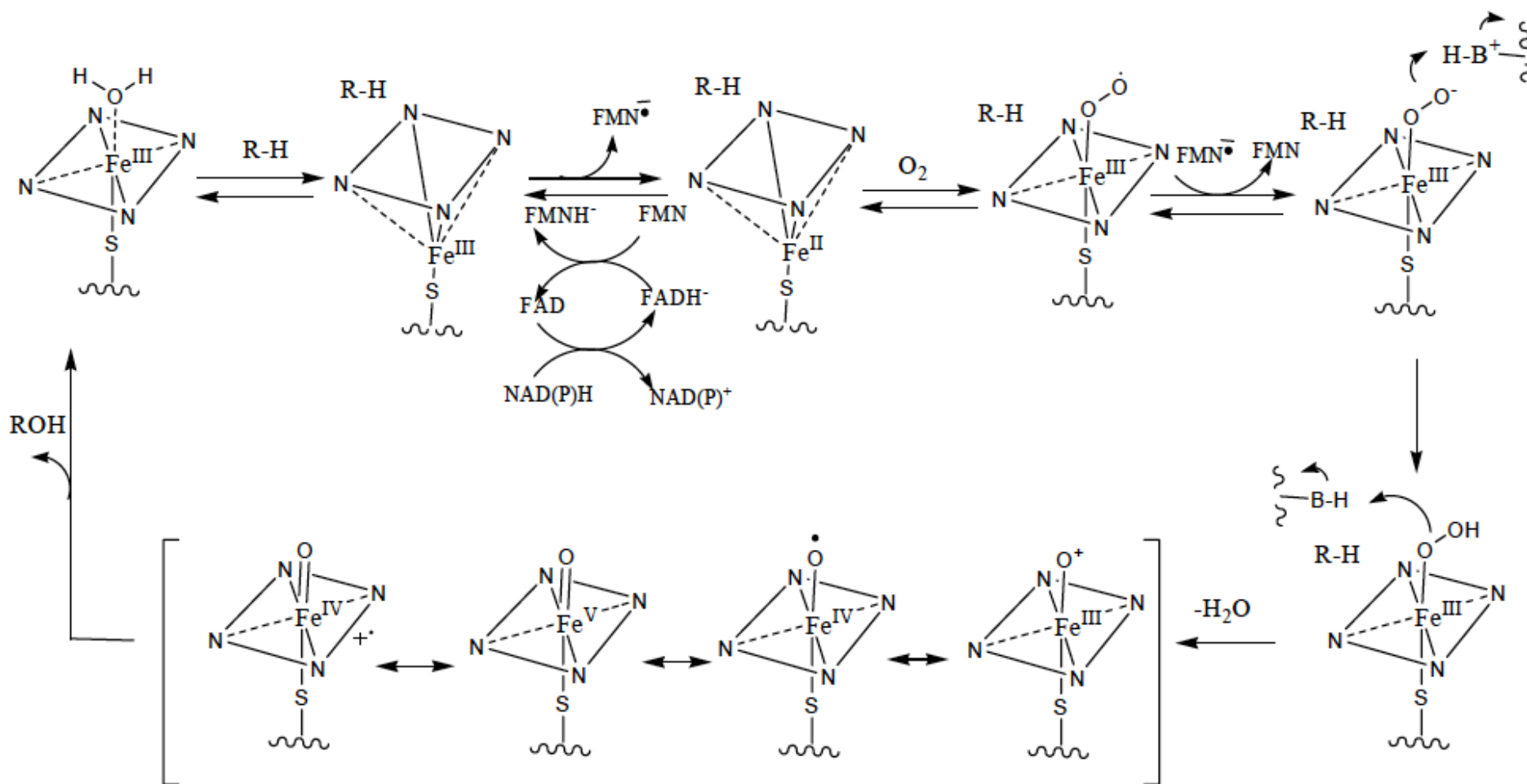

## **Heteroatom release (oxidation of sp<sup>3</sup> carbons adjacent to heteroatoms, O, N, S and Halogens)**

This process results from a formal hydroxylation at a carbon adjacent to a heteroatom leading to an unstable intermediate that results in cleavage between the carbon and the heteroatom.

### **O-dealkylation:**

P450 catalyzes O-dealkylation reactions by the two-step hydrogen atom abstraction/oxygen rebound mechanism similar to aliphatic hydroxylations. In the first step, the enzyme removes a hydrogen atom from the carbon adjacent to the oxygen (Hydrogen atom transfer, HAT), to generate a neutral carbon radical. Hydroxyl recombination follows in the second step to form a hemiacetal intermediate. The hemiacetal then dissociates non-enzymatically to an alcohol and a carbonyl compound.

This mechanism is supported by large kinetic deuterium isotope effects ( $k_H/k_D = 8-10$ ) measured during O-dealkylation reactions which were in the same range for P450 catalyzed aliphatic hydroxylations and chemical models. Loss or inversion of stereochemical configuration supports a two step mechanism.

# O-dealkylation

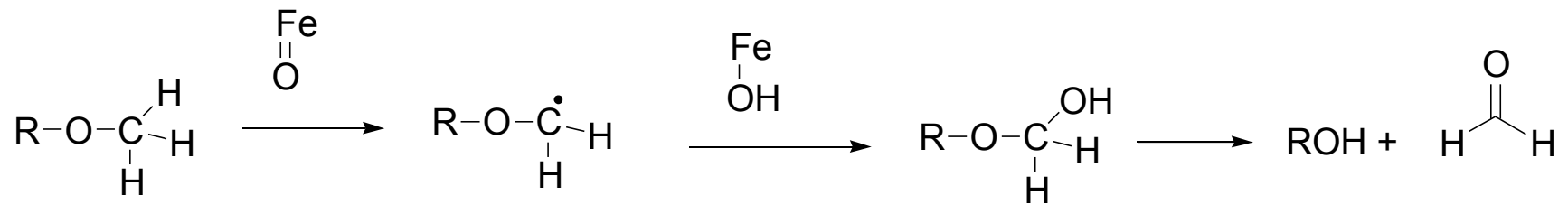

The R group in O-dealkylations can be alkyl or aromatic  
The carbonyl compound released could either be an aldehyde or a ketone.

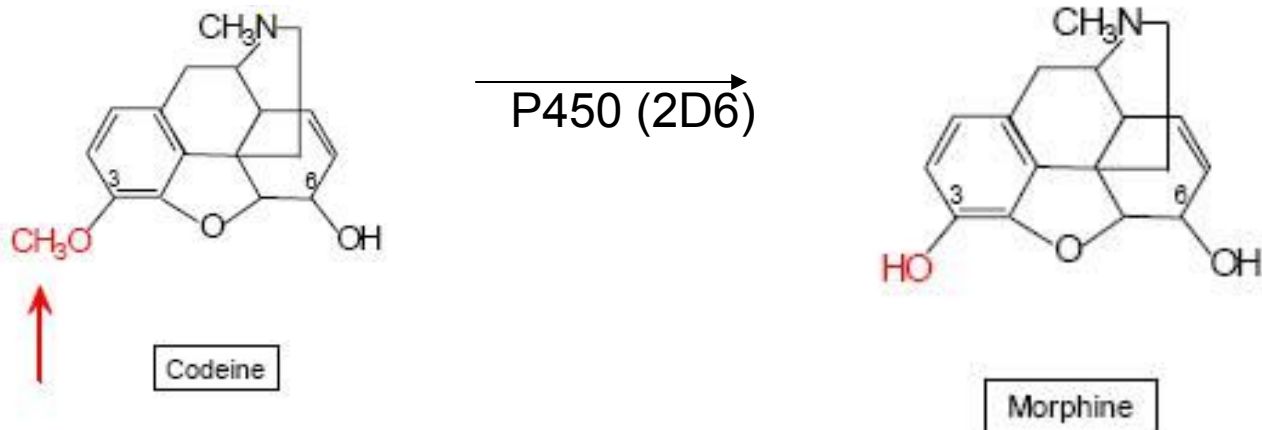

# Oxidative Dehalogenation

- When the carbon bearing the halogen also contains a hydrogen, hydroxylation occurs on the carbon. The hydroxylated products are unstable and react with loss of the halogen to give an acyl halide or a ketone. If other halogens are also present in the molecule then acyl halides result. Acyl halides can react with macromolecules (protein) and cause toxicity. These acyl halides have been implicated in the toxicity of chloroform and halothane.

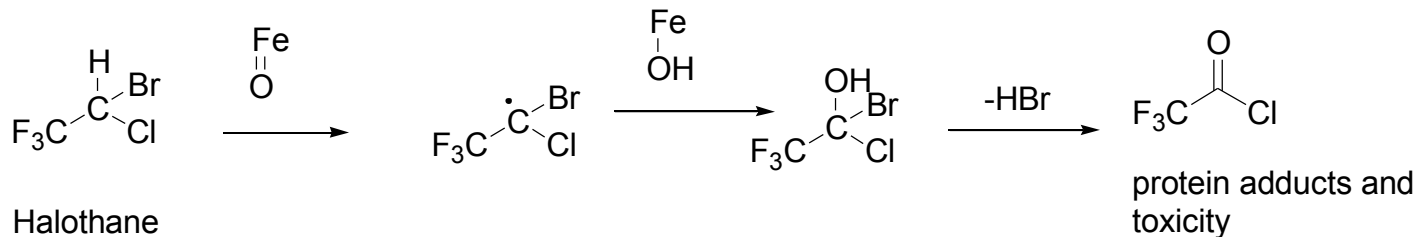
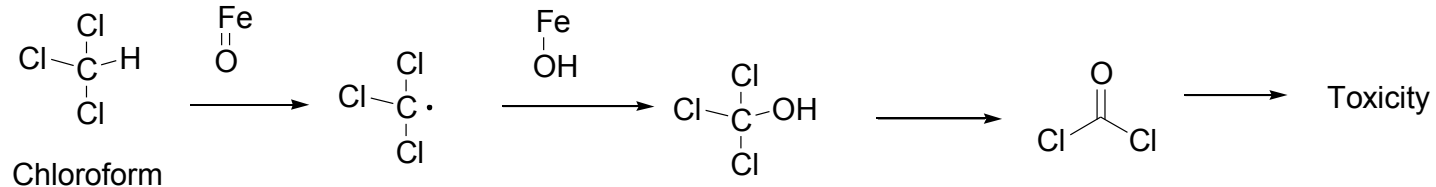

- When the Heteroatom is a nitrogen or a sulfur then the enzymes can either abstract a hydrogen atom from the molecule (HAT) or undergo single electron transfer. In some cases SET and HAT process on adjacent atoms may compete for the active oxygen leading to dealkylation or N, S oxidation.
- Factors affecting heteroatom oxidation include: oxidation potential of the heteroatom, the acidity of the adjacent hydrogens and to some extent steric factors.

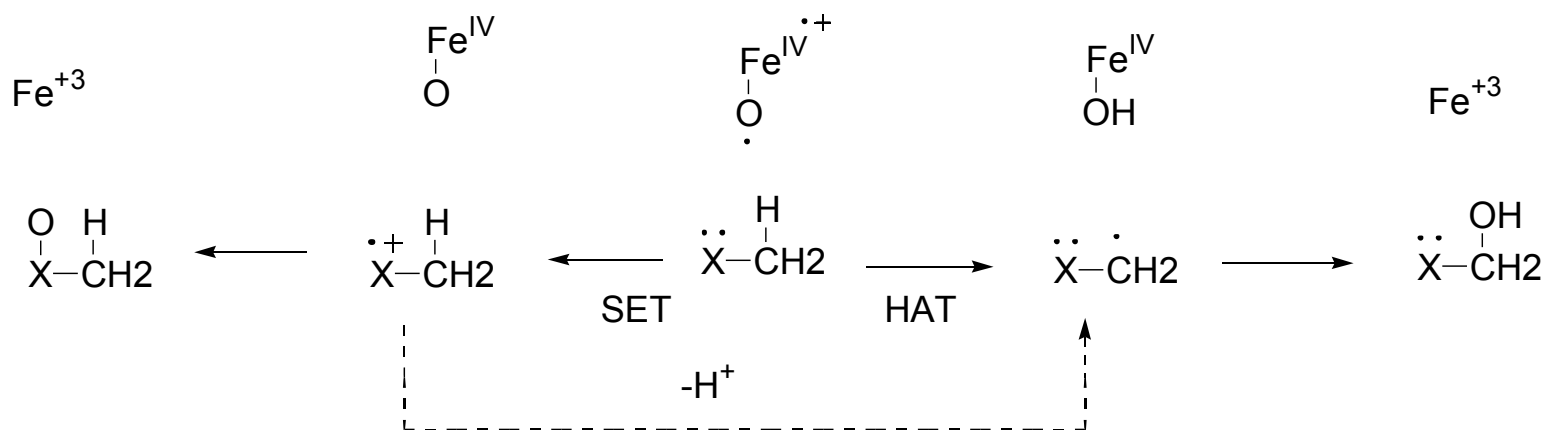

X= N or S

# Oxidation of sulfides

- P450 enzymes metabolize sulfides both to sulfoxides and S-dealkylation products. The sulfonium cation radical is formed as an intermediate in this process.

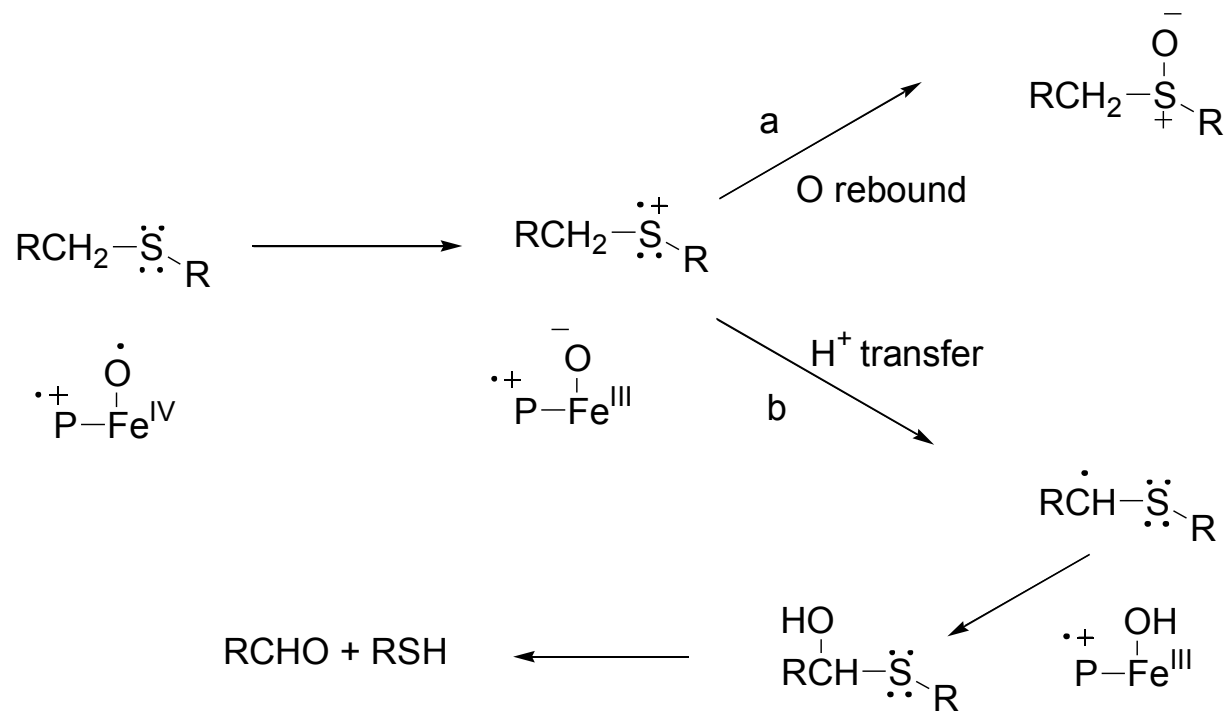

# Oxidation of Alkylamines

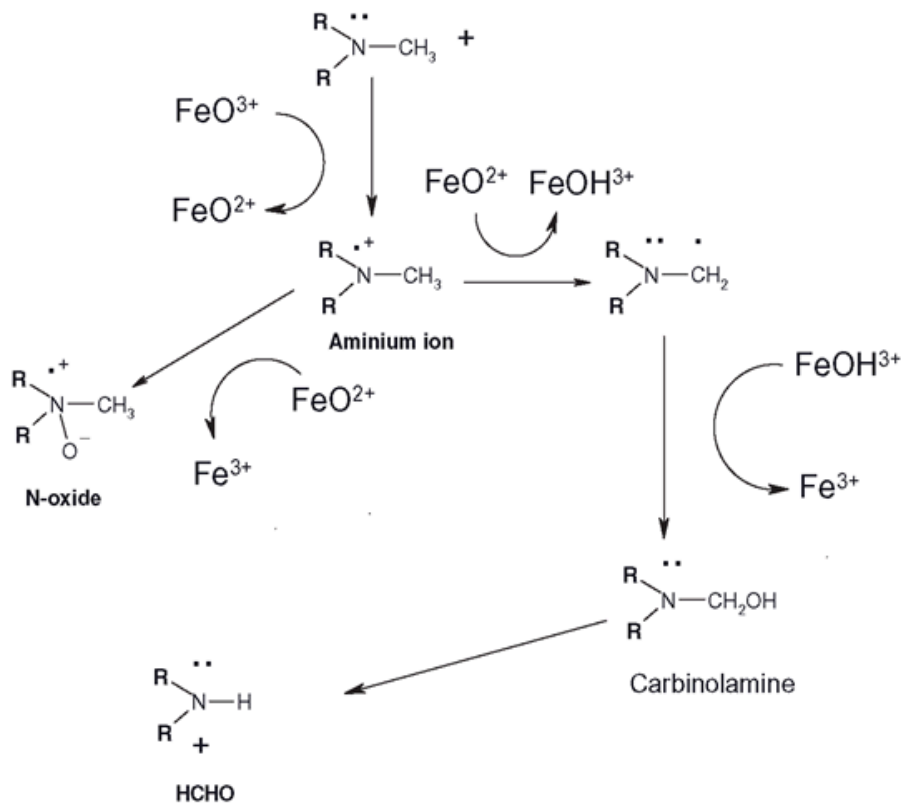

Amine nitrogens may be oxidized directly to give N-oxides or hydroxylamines (carbinolamines). N-oxidation are generally believed to involve transfer of an electron (SET) from the lone pair on the nitrogen to the perferryl species to generate compound II followed by oxygen recombination to give the N-oxide product.

N-dealkylation is a major metabolism pathway for many amine drugs. The products formed from N-dealkylation and O-dealkylation are similar (amine or alcohol and a carbonyl compound). Therefore there is no controversy about what products are formed. The controversy is how these metabolites are formed.



## Formation of MI complexes

Sequential oxidation of amines result in a highly stable, essentially irreversible complex with the reduced heme iron (metabolic intermediate MI complex). Several alkylamine drugs can cause drug-drug interactions by forming an MI complex (diltiazem, fluoxetine) Erythromycin below undergoes 4 sequential oxidations.

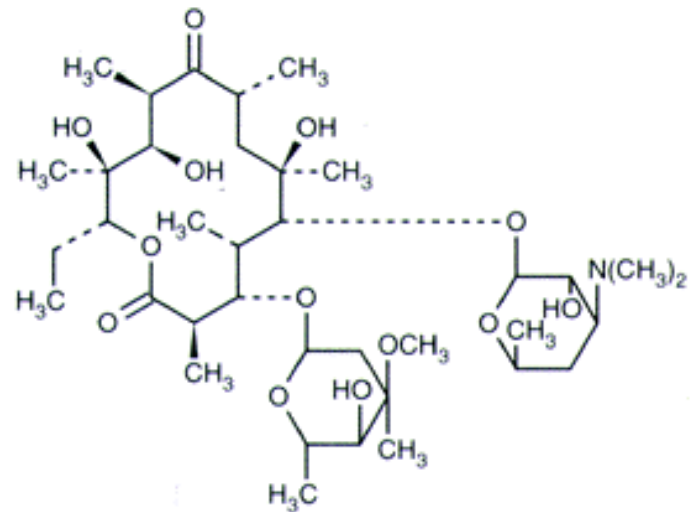
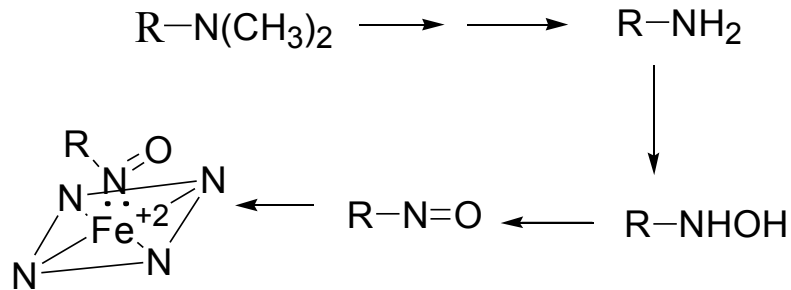

## Oxidation of pi bonds (epoxidations)

Epoxides (arene oxides, oxeranes) are formed from cyclic and acyclic olefins. Epoxides are of interest because they are electrophilic and can react with macromolecules (proteins and DNA) and cause toxicity. To prevent this the cells express epoxide hydrolases that catalyze the addition of a water molecule across the double bond to form diols.

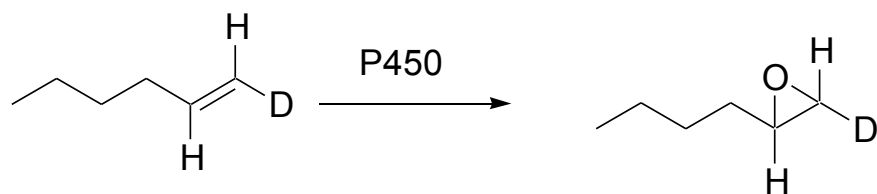

Epoxide formation with retention of configuration indicate that acyclic intermediates are extremely short lived. However other minor metabolites are formed that still suggest acyclic intermediates.

Olefinic compounds form N-alkylated heme adducts (from acyclic intermediates), therefore they serve as mechanism based inhibitors. Rearrangement products are also detected.

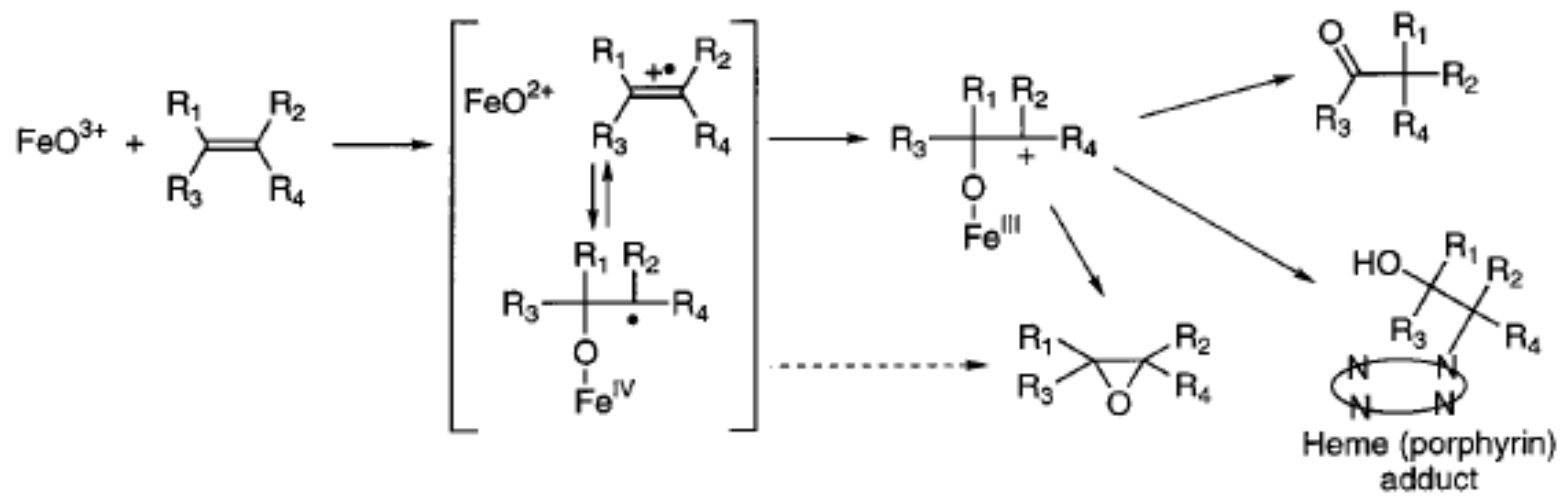

## Multiple oxidants in epoxidation reactions:

See page 13 in last classes notes. Vaz et al proposed that the hydroperoxo-species may play a role in epoxidations especially in mutants that remove the conserved Threonine residue, T302 in CYP2B4.

Vaz Alfin D. et al. (1998) Proc. Natl. Acad. Sci. USA 95, 3555-3560

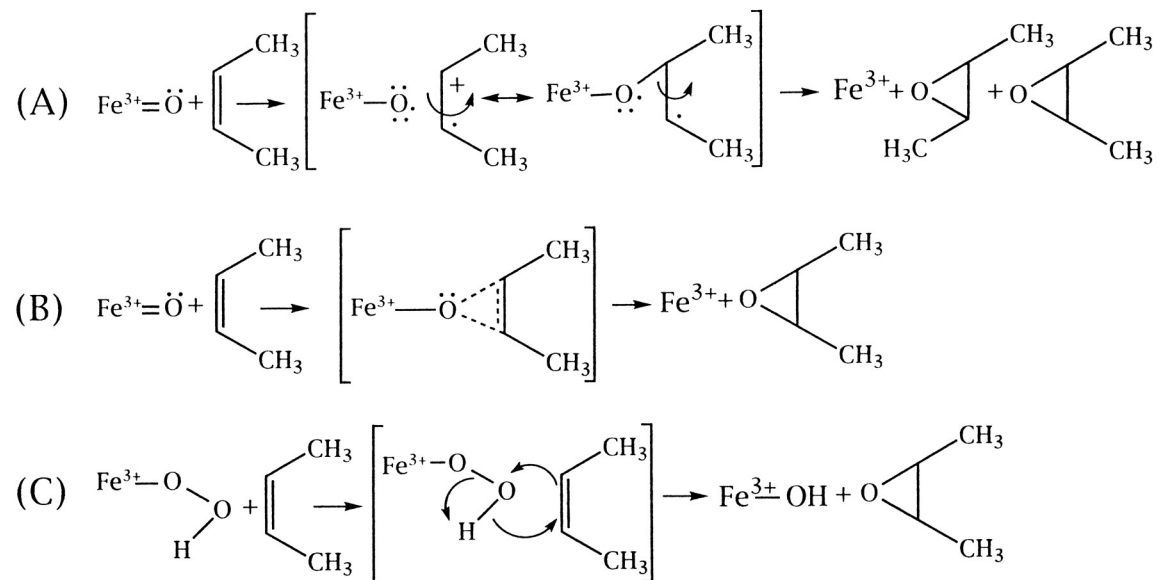

Mechanisms of olefin epoxidation (A) by oxenoid-iron involving a charge-transfer complex and leading to epimerization, (B) by oxenoid-iron leading to a concerted insertion of oxygen, and (C) by hydroperoxo-iron in a concerted reaction.

Shaik et al. have also applied the two state reactivity model for the epoxidation reaction. See: *Angew. Chem. Int. Ed* 41:1047 (2002).

## Oxidation of Acetylenes:

Acetylenes are much harder to oxidize than olefins. A few acetylenic drugs on the market. Acetylenes are subject to P450 oxidation as follows:

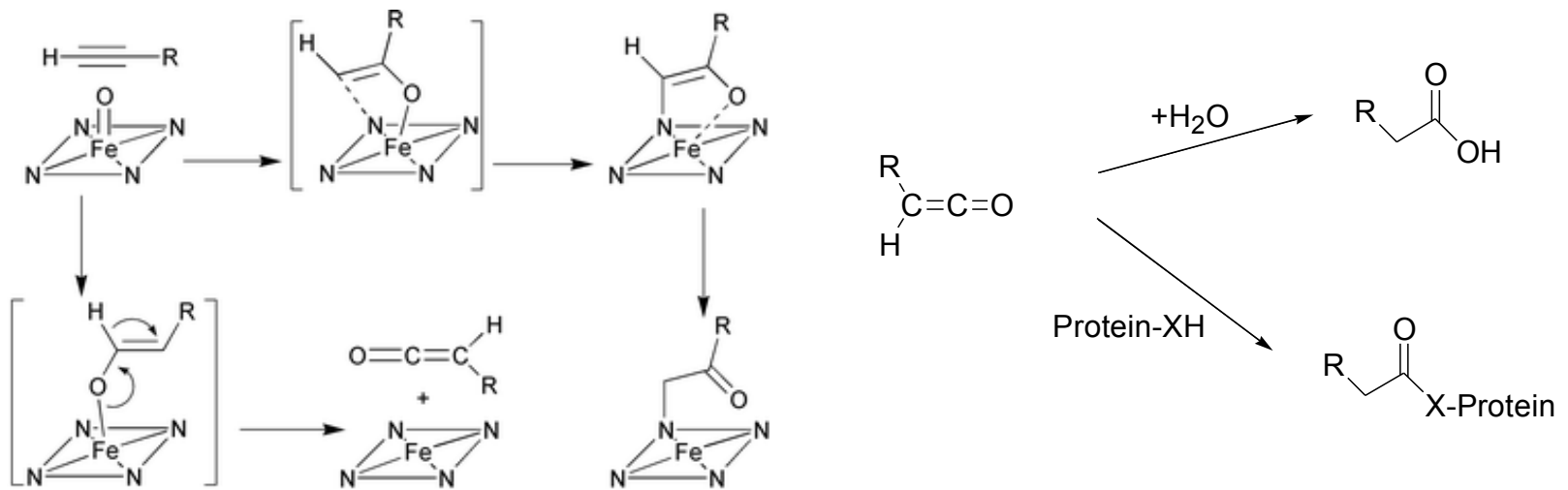

Oxidation of acetylenes parallels oxidation of olefins, although no epoxides are formed (oxirenes are antiaromatic and would not be formed).

Therefore, asymmetric attack on the triple bond. H-migration to form the ketene which can react with water to form acids or react with nucleophilic residues of protein and form inactive protein.

Another product is an intermediate that alkylates pyrrole nitrogens of the heme prosthetic group.

Since acetylenes inactivate both the heme and/or the protein they are known as ambidextrous suicide substrates.

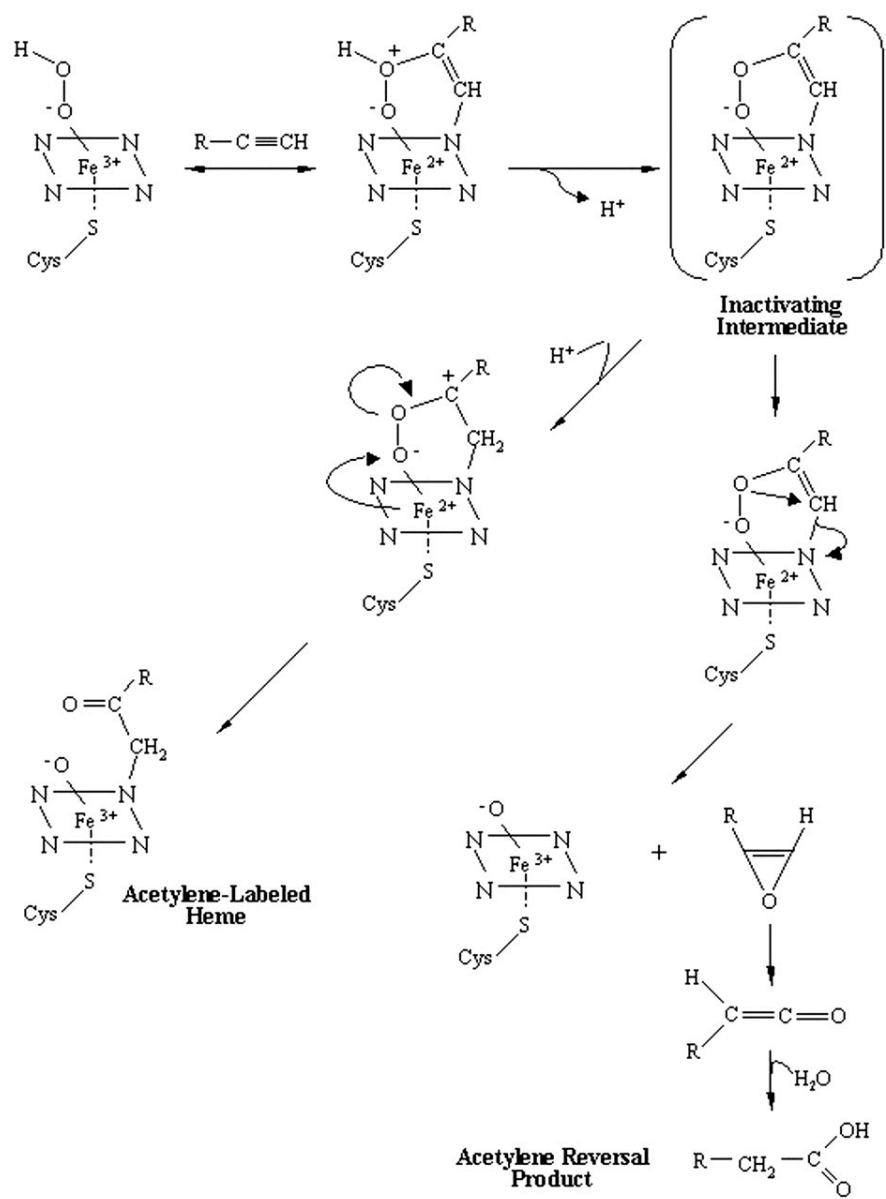

# Aromatic Hydroxylation (arene oxidation)

Aromatic rings are oxidized to phenols by P450 enzymes. The formation of the arene oxide intermediate is inferred as an intermediate that rearranges to give phenols.

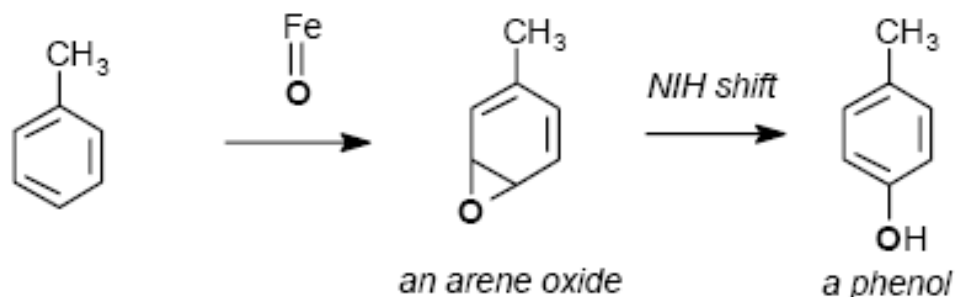

Retention of deuterium in the phenol product invoked a rearrangement called NIH shift in which either the deuterium or the hydrogen transfers positions in the enolization step. Methyl groups and halogens also migrate.

Two mechanisms have been proposed for arene oxides, stepwise and concerted. It is now accepted that aromatic epoxidations are not concerted and proceed stepwise.

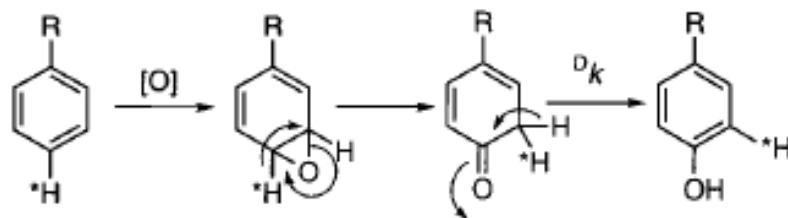

**Epoxidation of polycyclic aromatic hydrocarbons (PAH) have been implicated in macromolecule alkylation and toxicity.**

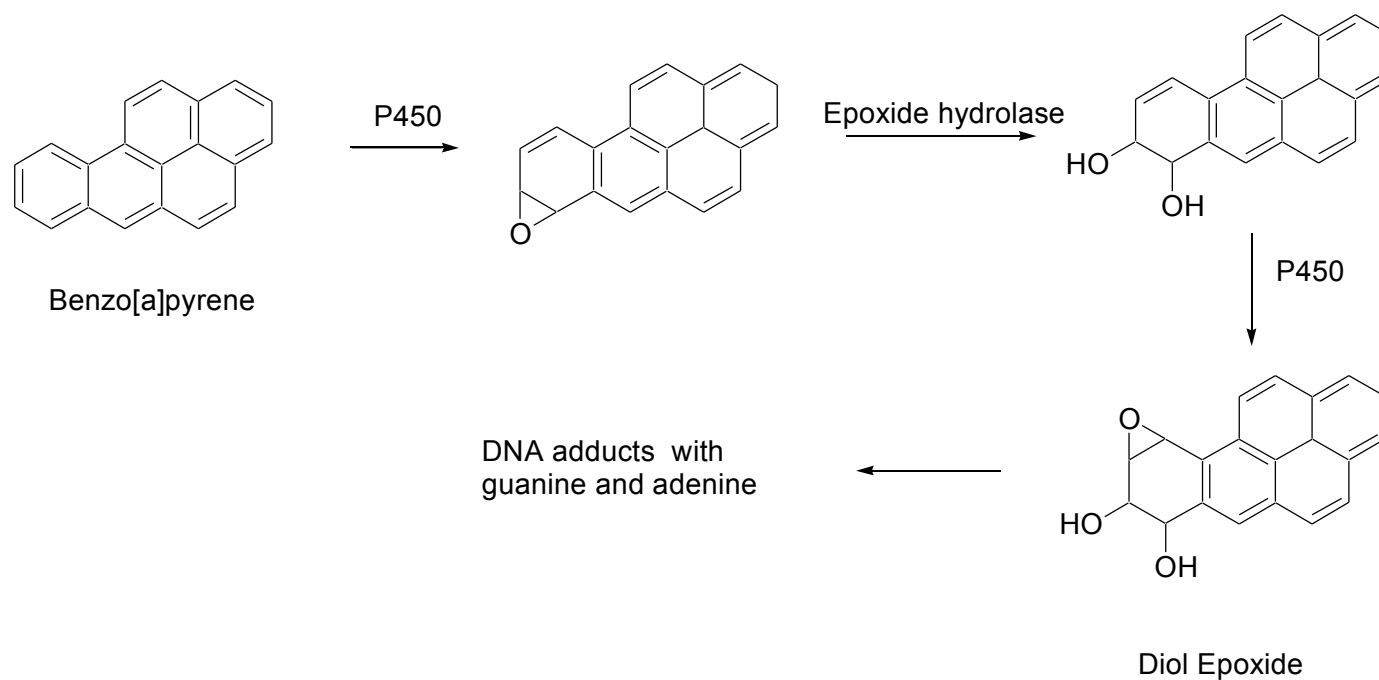



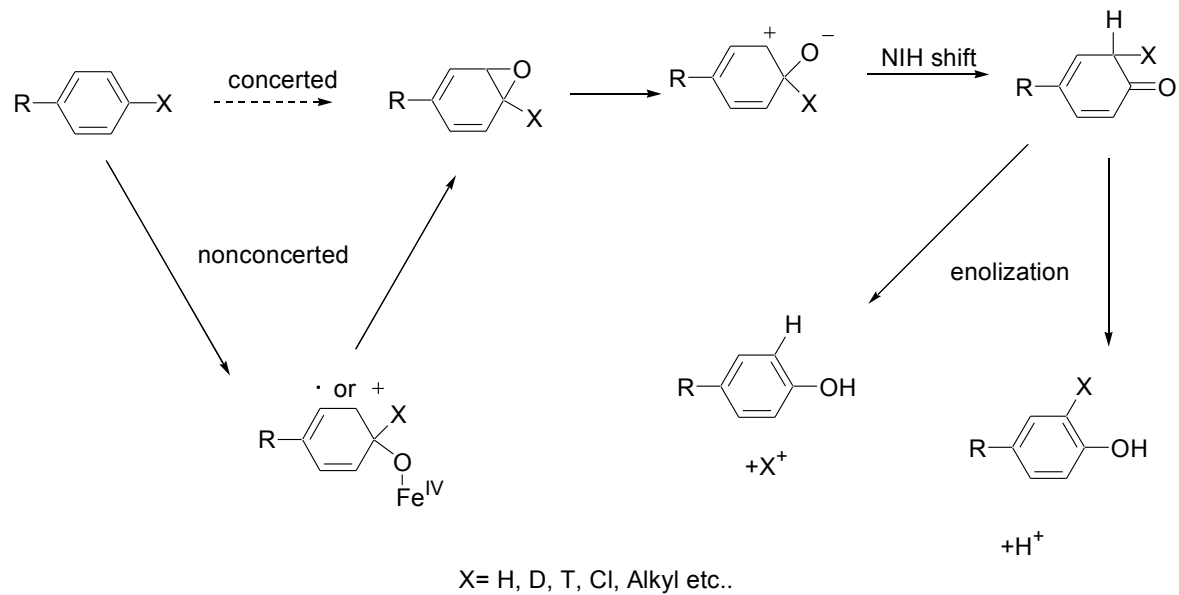

Epoxidation can occur on heterocycles as well and lead to macromolecule adducts.

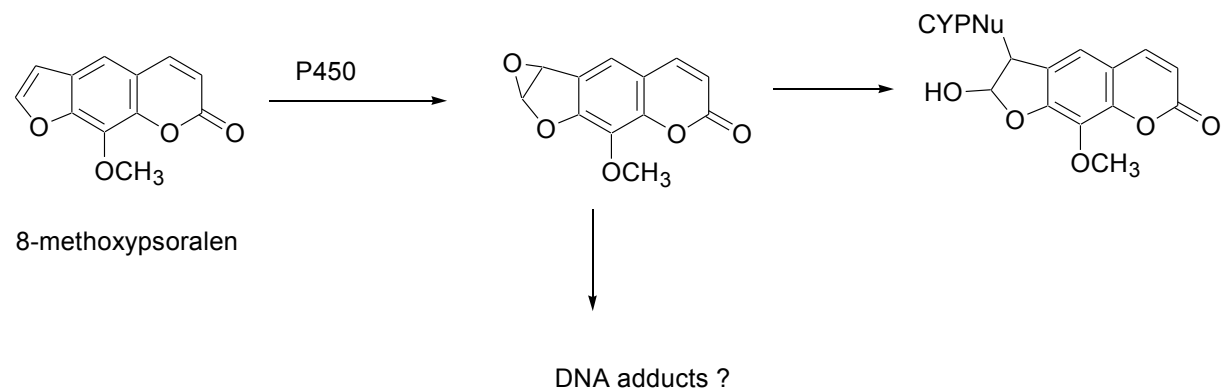

## Ipsso Addition on Aromatic Rings

- Ipsso attack occurs when oxidation occurs at a site of substitution (not on the ortho or para positions). Ipsso attack has been proposed to explain dehalogenation of phenols with net reduction.

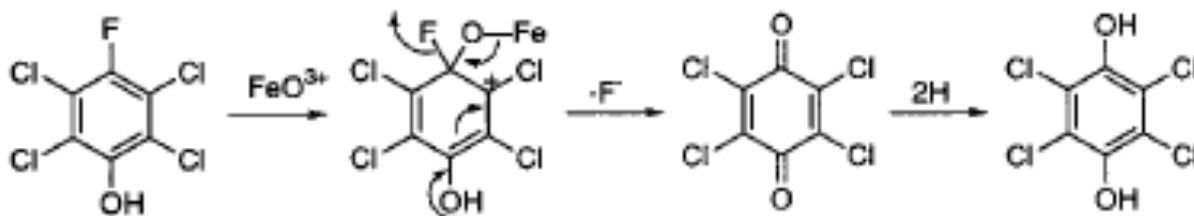

An ipso attack mechanism has been invoked to explain the incorporation of  $^{18}\text{O}$  into N-acetaminidoquinone (a metabolite during phenacetin oxidation).

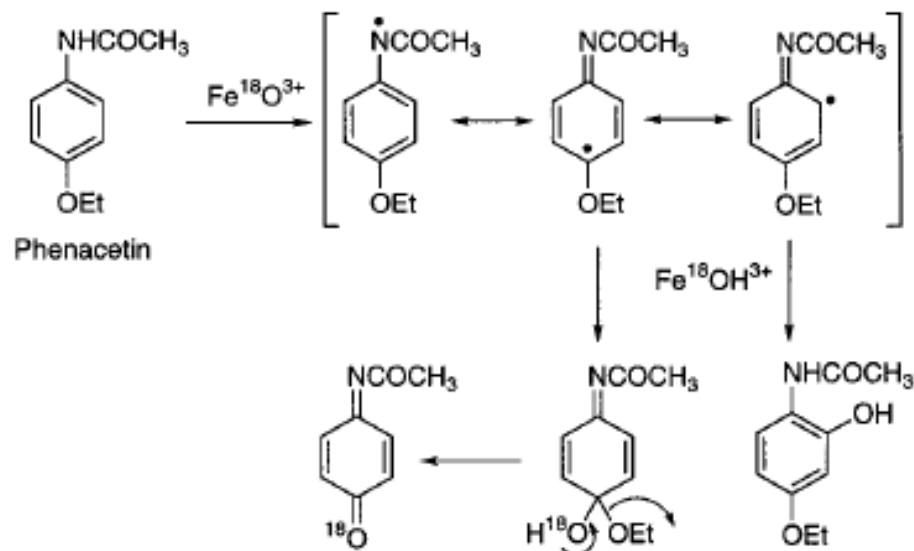

## Desaturation Reactions

Alkane desaturation is postulated to be part of C-hydroxylation mechanism. After abstraction of the hydrogen atom, the carbon radical can either undergo oxygen recombination (major pathway) to form an alcohol or abstraction of a second hydrogen atom and lead to unsaturation. In all known P450 desaturation reactions, C-hydroxylation is also observed as the main metabolic pathway.

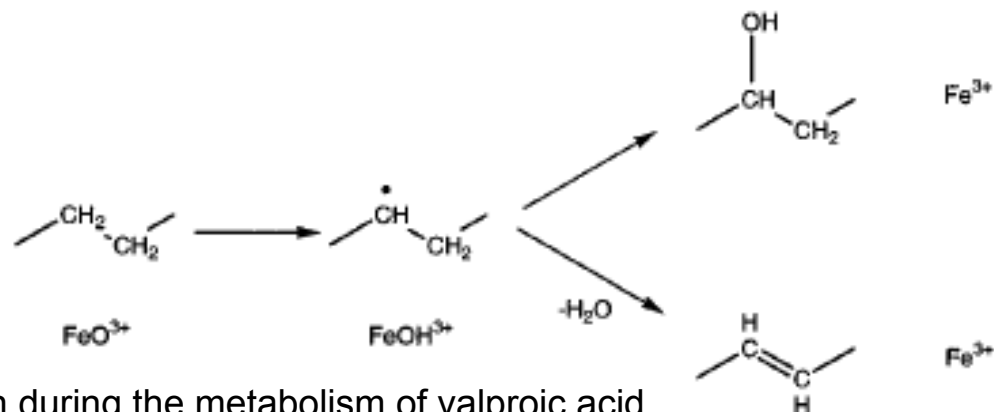

Example of desaturation during the metabolism of valproic acid

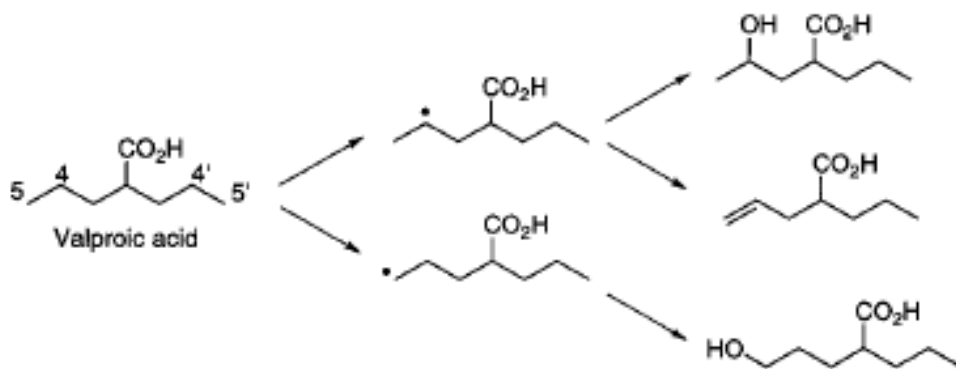

## Rearrangement and Isomerization Reactions

These reactions do not require a change in the oxidation state. Both the products and the starting materials are at the same oxidation state, but the requirement for P450 and NADPH has been shown.

Thromboxane synthase (P450<sup>5</sup>) converts prostaglandin H<sub>2</sub> to a 1:1:1 mixture of thromboxane A<sub>2</sub>, hydroxyheptatrienoic acid (HHT). These enzymes are found in the platelets and endothelial cells

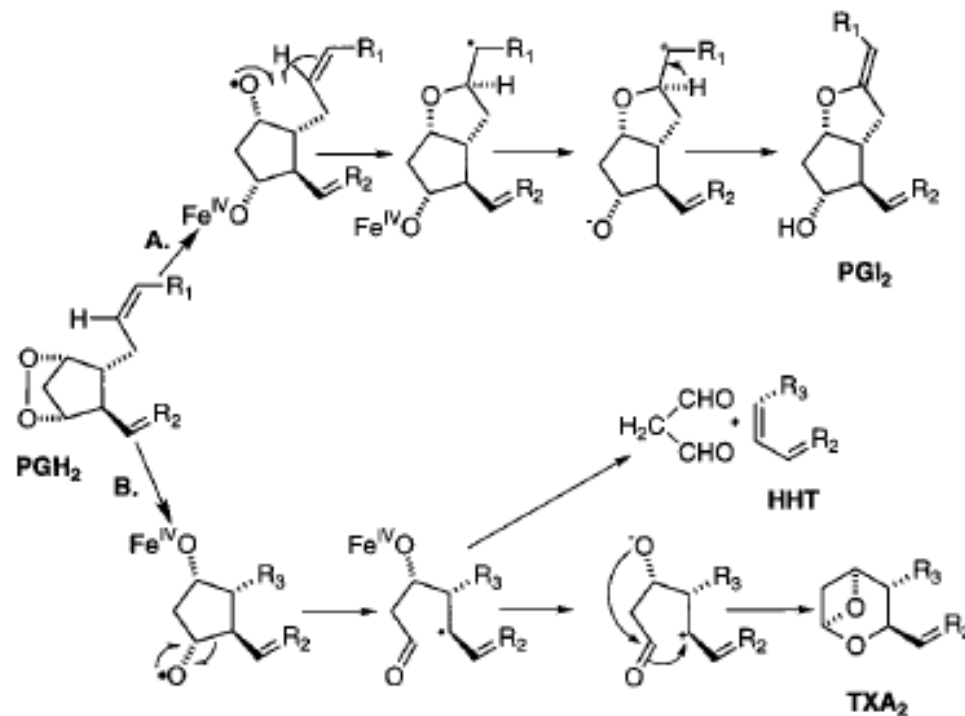

## Carbon-Carbon bond cleavage.

The C20-C22 bond of cholesterol is cleaved via three sequential oxidation steps by a specific mitochondrial cytochrome P450 (P450<sub>scc</sub>) to form pregnenolone.

