

The Franck-Hertz Experiment

Introduction

The original free-electron/mercury-atom collision experiment was first performed in 1914 by James Franck and Gustav Hertz who were later awarded the 1925 Nobel Prize for their work. Their simple, but elegant research represents one of the key experiments that helped to establish the “modern” atomic theory. In this experiment you will see evidence that atoms absorb energy only in quantum amounts, thus confirming what was then Bohr’s emerging quantum hypothesis.

The basic mercury device is an enclosed glass tube with three electrodes, referred to as a cathode, a control grid, and an anode (see Fig. 1). In addition, there is a small drop of pure mercury placed inside the evacuated tube whose vapor pressure is carefully adjusted by heating this environment. Electrons are thermionically emitted from the cathode, usually heated indirectly by a tungsten filament at a temperature of about 2500 K. The anode is also referred to as the collector and it is negatively biased relative to the control grid by a small potential of about 1.5 volts. The control grid itself is grounded and the cathode is biased by a negative potential V_{accel} relative to the grid (typically by many tens of volts). The electric field between the cathode and grid accelerates electrons emitted from the cathode toward the grid and anode.

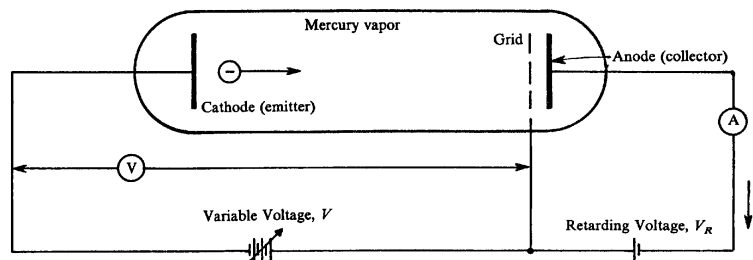

Figure 1: Schematic diagram of the Franck-Hertz tube.

On average, these accelerating electrons will travel a distance, λ , (referred to as the mean free path) before colliding with one of the mercury atoms in the vapor. As a result, they will pick up some average increase in kinetic energy before making a collision (either elastic or inelastic). For an elastic collision with a heavy mercury atom, the average energy lost by the electron is very small. Most elastic collisions cause the electron to scatter only through small angles relative to the original direction. This means that in the first approximation, we may treat elastic collisions as if they did not occur (although the elastically scattered electrons do contribute to the baseline slope of current versus V_{accel} plot, and more recent work suggests that elastic collisions play a role in energy loss, significantly at low voltages [1, 2]). At some critical value of V_{accel} electrons will acquire enough energy to undergo *inelastic* collisions with the mercury atoms, putting the mercury atoms into excited states. Inelastic collisions can remove a lot of kinetic energy from the free electrons, and the effective mean-free path, λ_{in} ,

between *inelastic* collisions is much greater than λ that includes both elastic and inelastic collisions.

In general, the excitation cross-sections for an inelastic absorption of energy rise rapidly when the energy of the free electron approaches the energy difference between two stationary states of the excitable atom. A “cross-section” in this context is a way of specifying the likelihood of an interaction between the electron and the mercury atom. You can think of it as a kind of “resonance.” These “inelastic cross-sections” do not drop off to zero immediately after the electron energy exceeds this excitation energy, because energy is not quantized for the *free* electron and it can carry away the energy difference. From Fig. 2, the first possible absorption for mercury (as the accelerating potential is increased) occurs at 4.64 volts, when the atom is promoted from its 1S_0 ground state to the 3P_0 state.

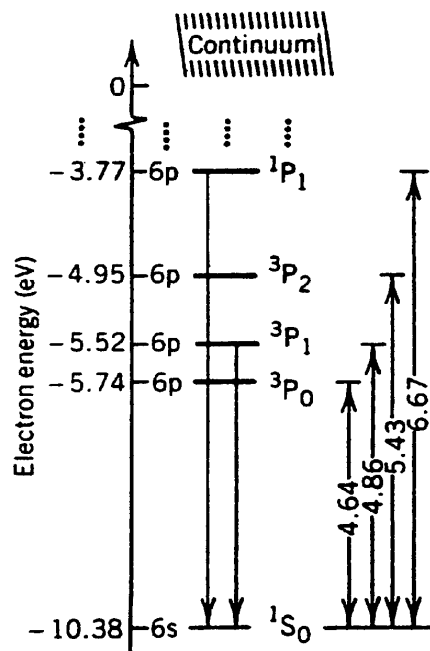

Figure 2: Simplified energy level diagram of mercury, relevant to this experiment. Energy level separation in electron volts is indicated on the right.

Note that no electron current will be sensed by the anode until the accelerating potential exceeds 1.5 volts because of the retarding potential between the collector anode and the control grid. After that, the current is observed to increase with increasing V_{accel} until the first inelastic collision occurs. Collisions of this type will occur when the electrons gain this amount of energy from the applied field, which will be when the potential difference between the cathode and the grid is close to the lowest excitation energy of the mercury atom. At this voltage, these collisions occur near the grid, and electrons that lose this much energy may not be observed to arrive at the collector because of the retarding potential; they are collected at the grid instead. If the accelerating potential is increased, the region where inelastic collisions occur will move away from the grid toward the cathode, and the electrons will start accelerating again (if V_{accel} is large enough) and possibly later cause another inelastic

collision near the grid, again to the lowest excited state at an accelerating voltage equal to twice the lowest-excited-state energy. Indeed, as the accelerating voltage is further increased, the same electron *may cause atomic excitations multiple times, and we see the anode current vary in a periodic manner with a period equal to the lowest excited-state energy.*

When the atoms are excited by the electron collisions, they relax back to their ground state through the emission of light. The photons emitted typically have energy equal to the energy of excitation. However, the lowest excited state of mercury is about 4.6 electron volts (eV), which is an energy in the ultraviolet. Visible light spans wavelengths λ of about 400 to 700 nanometers, corresponding to energy (hc/λ) of 3.1 to 1.8 eV. We cannot see the light emitted by the mercury atoms in this process, but Franck and Hertz measured this light emission with a detector that was sensitive to UV light. However, the same essential physics occurs in other atoms, such as neon (Ne). In this case, the first excited states are much higher in energy, and are clustered in a range from 16.6 to 16.9 eV, which are also too high in energy to see, but the second cluster of excited states is only a little higher, from 18.4 to 19.0 eV. Because the two groups of states are relatively close together, and because there can be transitions between the two groups of excited states which produce light in the visible range (1.6–1.9 eV), the Franck-Hertz experiment carried out with neon shows a similar periodicity in the anode current with a much larger period in accelerating voltage. And it is accompanied by a pattern of glowing bands of orange light that develop near the grid, with each new band moving away from the grid toward the cathode as the accelerating voltage is increased.

The description of the Franck-Hertz experiment above is necessarily oversimplified. The specific dynamics of electron-atom collisions are quite complicated and have been studied for many years. Modern approaches to the problem involve either direct simulations of the atoms (molecular dynamics) or numerical solutions of a class of differential equations known as Boltzmann transport equations [2]. Electron-atom collisions in gases are of particular interest to designers of particle detectors, which use such gases to sense the energy of high-energy particles, such as cosmic ray muons or x-rays.

There is still a role for simpler models that can describe essential features of the Franck-Hertz experiment, but go beyond the description given so far. One example is a paper by Rapior, Sengstock, and Baev (RSB), published in 2006 [3]. Among the effects that this model describes are the increasing spacing between peaks (or troughs) in the periodic signal of anode current vs. acceleration voltage, the effect of temperature on the peak spacing in the Hg experiment, and an explanation of why the peak spacing is typically wider than the energy of the first (lowest) excited state of the atom.

As part of the data analysis, you will apply the procedure described by RSB to compare to the simple average-spacing result, and to also see how well their model works with your data set. You will need to read through the paper to learn the details; a copy of the paper is linked on the course website.

You will also run the same experiment for a Franck-Hertz tube containing neon, and you will also observe the glowing bands of light and compare their behavior to the anode current curve.

And, you will explore the utility of applying an AC bias to the accelerating potential and use small modulation of the anode current by this bias to make experimental measurements of the *derivative* of the anode current vs. voltage. The derivative curve highlights changes in the local slope of the curve, and these changes are related to the onset of additional energy levels. By measuring the differences between smaller features in the neon current curve, you can correlate those with the energy split between the excited states of neon, the $3s$ and $3p$ states.

1 *The experiment*

Your basic data sets will be plots of anode current versus accelerating potential, V_{accel} , and the corresponding derivative plots using a lock-in amplifier.

For mercury, you will determine the excitation energy for the 6^3P_0 state relative to the 6^1S_0 ground state in mercury.

The curves for neon will look quite different because the minimum excitation energy is much higher and there are many excited states that are close together. These states may be grouped into 4 $3s$ states and 10 $3p$ states which are separated by a gap of about 1.7 eV. A derivative plot of this curve will show striking small features with a separation close to this voltage. You may also take note when visible bands can be observed in neon in relation to magnitude of anode current.

Experimental Goals: (1) Measure the first excited states of Hg and Ne from the anode current versus accelerating voltage curves. (2) Observe the emission of light and the relationship between the light pattern and the anode current curve for Ne. (3) Use the lock-in amplifier to take an experimental “derivative” of the anode current curve, and use this to estimate the energy separation between the $3s$ and $3p$ states of Ne. (4) Apply the model of Rapior, Sengstock and Baev to the data, and see how well it works.

1.1 Exercises

1. Should the fact that electrons are released from a heated cathode affect the width of the peaks seen in the mercury-tube data? Apply a model that assumes that the spread in energy of the electrons about the mean value specified by the acceleration voltage depends on their temperature. Calculate the kinetic energy gained on the average by an electron thermionically emitted from an indirectly heated cathode which is typically at a temperature of about $T \approx 2000$ K. What effect will the distribution of velocities of these electrons have on the sharpness of the peaks in the anode current $I(V_{\text{accel}})$ plot? You may need to review the theory of the Maxwell-Boltzmann distribution of velocities.
2. Estimate the distance, λ , (referred to as the mean free path) that the free electrons will travel on the average before elastically colliding with one of the background mercury atoms. For this purpose, you will need the value for the vapor pressure of Hg found

in the *Handbook of Chemistry and Physics*, or the table posted on the course webpage from *Lange's Handbook of Chemistry*. You may use the estimated radius of the neutral Hg atom of 160 pm (picometers) to calculate a collision cross section [4, p. 114].

3. Estimate the worst-case loss of energy that a free electron can have in an *elastic* collision with a mercury atom, assumed on the average to be at rest in the tube.
4. Estimate the longest effective mean-free path, λ_{in} , for inelastic collisions that one could observe in the mercury tube. (Hint, see an old non-functioning Franck-Hertz tube, available in the lab.)

2 Apparatus and Procedure

2.1 Apparatus

The accelerating potential applied to the mercury and neon Franck-Hertz tubes is generated by the electronics inside the FRANCK-HERTZ RAMP GENERATOR box. The time varying potential generated by this box is a ramp waveform that looks like Fig. 3.

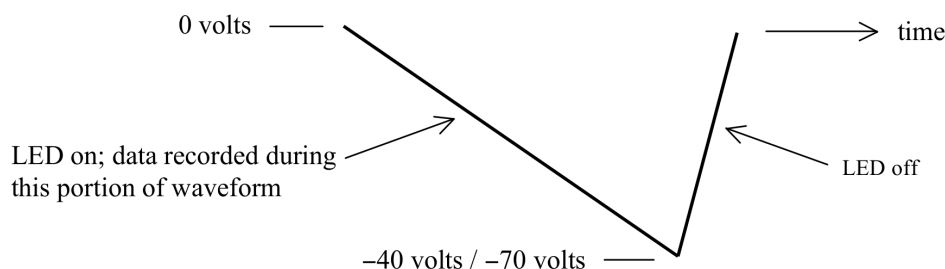

Figure 3: Voltage ramp used to modulate accelerating potential.

The -40 volt potential is applied to the mercury tube, and the -70 volt potential is applied to the neon tube.

For the mercury tube the accelerating potential generated by the box is applied between the cathode and anode, with the anode kept at ground potential. In addition to this time varying potential, a small static retarding (decelerating) potential is applied between the grid and anode. A battery generates the static potential, equal to 1.5 volts in the mercury set-up. The schematic of the cathode, grid, anode and applied potentials is shown in Fig. 4.

The neon tube (Fig. 5) has an additional electrode in the form of a grid located close to the cathode (grid 1). A small fixed potential (1.5 V) is applied between this grid and the cathode to accelerate electrons from the charge cloud surrounding the cathode. The accelerating potential from the RAMP GENERATOR box is applied between the anode, again at ground, and grid 1.

In both tubes the field that accelerates the electrons is due to the combination of the variable potential and the fixed retarding potential. The meter which monitors the accelerating

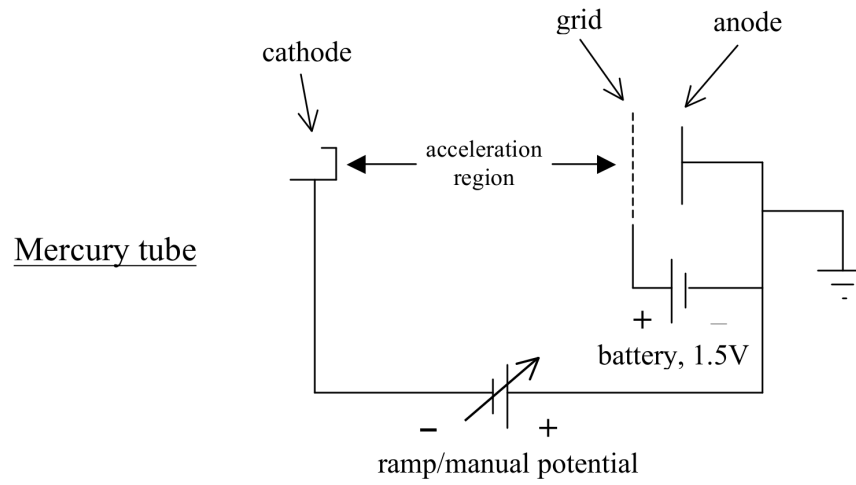

Figure 4: Apparatus schematic for the mercury tube.

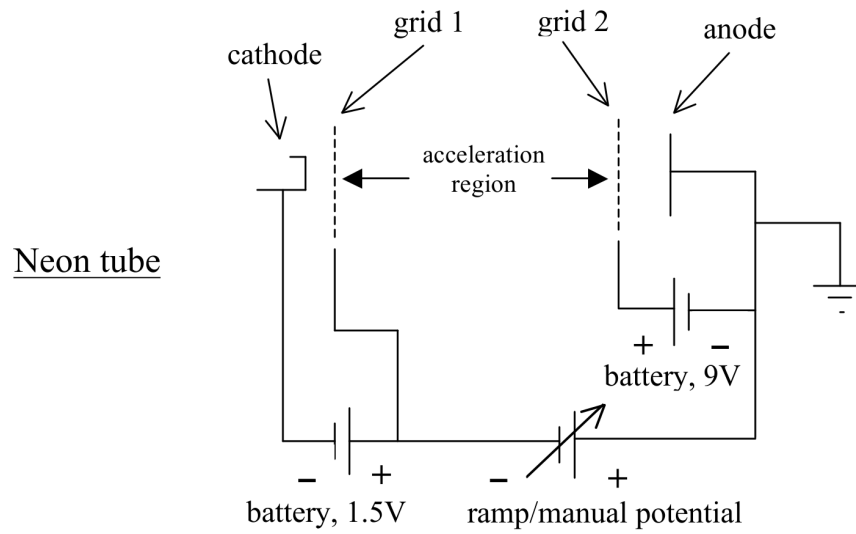

Figure 5: Apparatus schematic for the neon tube.

potential (between the grid and anode in the mercury set-up, and between the two grids in the neon set-up) will thus indicate a maximum value greater than the maximum potential generated by the box alone.

The RAMP GENERATOR box has a number of features described as follows. The waveform frequency can be set high (50 Hz) or very low (0.03 Hz or 0.004 Hz). The high frequency setting is useful for looking at the ramp waveform on a scope to check out its shape and upper and lower limits. The 33 second period (0.03 Hz) is useful for checking out the chart recorder settings. For recording data, the 250 second period (0.004 Hz) should be selected, as this slower speed will allow the electronics more accurately track the signal, especially when using the lock-in amplifier which has a slow response to a changing input.

A switch directs the ramp output to either the mercury set-up (0 to -40 volt output connector) or the neon set-up (0 to -70 volt output connector). The ramp output can also be switched off entirely, in which case the selected output is connected to ground.

In addition to generating the accelerating potential like that shown in Fig. 3, the potential can be manually set with the COARSE and FINE 10-turn potentiometers. A switch selects between MANUAL and RAMP (waveform) options.

Data are recorded during the negative-going portion of the waveform. During this portion, the LED is on and the same signal is available at the PEN UP/DOWN output on the box, which may be used to control when the chart recorder should make a trace. (Note: this feature is not used with the electronic chart recorder.)

When the two power supplies for the RAMP GENERATOR box are first turned on, the ramp output saturates at a positive voltage for a minute or so. (This is also the case when you switch from 33 s to 250 s.) After a while the ramp output will start going negative and will then vary in time as shown in Fig. 3.

Offset and gain controls are also provided to allow for fine tuning these parameters on the output waveform. Normally, these do not need to be changed.

An additional feature of the RAMP GENERATOR electronics is that a small modulating signal can be added to the ramp output, thus allowing for lock-in detection of the derivative of the anode current. The potential differences between successive anode current maxima are the numbers of interest in this experiment, and the lock-in scheme conveniently provides a very sensitive method for detecting the potentials at which these maxima occur. If you are not familiar with this method of lock-in detection, see [5].

2.2 Procedure

The mercury tube oven needs to be brought up to working temperature before you collect data. Let it warm up while you collect data for the neon tube (which is a gas at room temperature and needs no warming).

Turn on the Variac controlling the oven heater in the mercury tube housing and set it to 65 V. This setting will bring the temperature inside the housing to approximately 160 C at equilibrium in about 1/2 hour.

NOTE: The thermostat on the mercury tube oven does not work: the knob on the side of the mercury-tube's housing should be turned fully clockwise. The temperature is controlled by the Variac setting only. **Keep the Variac setting at or below 65 V**, however, you may turn it up to 100 V for less than 5 minutes at the beginning to warm the oven up more quickly.

2.2.1 Neon set-up

Turn the current control knob on the filament current supply box fully counterclockwise so that it reads 0. Turn the “Current Output” switch off. If the leads attached to the “Filament Out” terminals (BLUE and WHITE) on the current supply are connected to the mercury tube setup, remove them and connect them to the neon tube base at the “Filament Current” terminals. Note polarity of the leads: BLUE should connect to BLACK (–) and WHITE should connect to RED (+). Turn on the power supply (little HP6213A) and set its voltage to 10 volts.

Then turn on the output switch and increase the neon tube filament current to 240–245 mA. A filament current in this range should make for easily visible bands when the accelerating potential is applied to the tube.

CAUTION: Be very careful when adjusting the filament current. **The filament can easily be burned out by setting the current too high.**

2.2.2 Ramp generator and Chart recorder

NOTE: As of Spring 2023, the electromechanical paper-based chart recorder seen in videos and other instructional materials has been replaced with a computer version written with LabVIEW that uses a National Instruments (NI) data acquisition unit (“NI box”) to collect the measurements.

Log in to the workstation computer near the experiment. You should use the “Student” or “lab” account, unless you have a specific need to use a personal NetID account. The Student account will load more quickly and provide access to other group members or instructors.

Look for the icon labeled **Chart Recorder**. (Do NOT look for “LabVIEW.” The chart recorder is already a stand-alone application.) Start the application, and give it a minute or so to become ready.

The NI box is already connected to the experiment, with its analog input Channel 1 connected to the “Plotter Y Axis” output on the X-Y PLOTTER INPUT SELECT BOX (below called the X-Y SWITCHBOX) through a simple RC lowpass filter and Channel 2 connected to “Plotter X Axis” output via the acceleration voltage attenuator. The attenuator is necessary because the NI data acquisition system’s maximum input is 10 volts, and the acceleration voltage applied to the neon tube is about 70 volts. The attenuator divides the acceleration voltage by (approximately) 10 to bring in into a measurable range. One of your tasks will be to calibrate the measured acceleration voltage against the external voltmeter (on top of the lock-in amplifier); this is discussed in section 2.2.4.

After the Chart Recorder application starts, click on the tabs at the top left to set the scan parameters. The following settings should produce a nicely visible trace (if the setting is not specified, the default value is acceptable):

Channel 1 Check the box next to **Enable Ch 1**. Check the box next to **Invert signal**. The anode current is negative (do you see why?) and it causes the current amplifier to produce a negative voltage. This check box flips the signal to positive.

Channel 2 Check the box next to **Enable Ch 2**.

Channel 3 Ensure that no boxes are checked here. We are not using Channel 3.

Sample Clock The sample clock controls how often a measurement is recorded by the interface box. Because of the presence of electrical noise, we will average clusters of closely-spaced measurements to obtain each recorded data point. This reduces the effective rate of data collection but it also reduces the jitter in the data record. To enable this on-the-fly averaging, Check the box **Pre-bin samples** and set **Bins/Read-cycle** to 5. With 100 samples per read cycle (the default) divided into 5 bins, this averages successive groups of 20 readings into one reading, and shifts the effective sample rate to 100 measurements/second down from the default 2000 samples/second.

On the X-Y SWITCHBOX, set the “Plotter Y-Axis” to “PDA-700”.

Turn your attention to the RAMP GENERATOR. Switch the RAMP SPAN to -70 volts; this will automatically connect the output to the 70 volt connector that is wired to the neon-tube apparatus. Turn the COARSE adjust potentiometer on the RAMP GENERATOR box fully counterclockwise.

The PDA-700 for the neon setup should be set to 200 nA full scale. (Note: “200 nA full scale” does not mean the output reads “200.00”. It means the output looks like “00.00” with the “nA” label highlighted. The maximum reading would be “199.99 nA”.)

With the MANUAL/RAMP switch in the MANUAL position, turn it clockwise to confirm two things: (1) the acceleration voltage measured by the voltmeter should go up and (2) you should see the reading on the PDA-700 increase and decrease in a periodic manner (the current is negative). If you fail to get a signal, ask for help.

Now check the ramp signal: switch the OUTPUT from MANUAL to RAMP, and Select the 33 second ramp period.

Go back to the Chart Recorder and select the **Scan Controls** tab and click **TAKE SCAN**, and see what you get. *There may be a slight delay before you see data, especially when the Chart Recorder is used for the first time.* If you do not see traces appear on the screen after a couple of attempts, please ask for help!

You should see two traces, one may be fairly weak, only varying by a few tenths of a volt. That is the Channel 1 signal, which is measuring currents in the nanoamp range. The other signal (Channel 2) should be a large triangular wave with a slow ramp up and a fast ramp back down. This is the acceleration voltage signal, which should vary by 7 volts or so.

Stop the scan, and select the **Channel 2** tab. Then check the box next to **Set as X-axis**. This will make the recorder use the ramp signal as the x-axis of the scan, Now you should see a series of broad humps, and possibly overlapping traces if there is more than one cycle of the ramp, with the x-axis showing a voltage range of about 0 to 7 volts.

Select the 250 second ramp period. You may need to wait for a few minutes until the ramp starts increasing when you choose the 250s period (the internal capacitor is large and takes a while to reach its steady state operating potential).

After the 250s cycle is working properly, time your start and stop of taking the trace by watching the voltmeter and the LED on the RAMP GENERATOR box. The LED is OFF when the ramp is resetting and ON when the “good” part of the scan is occurring. Wait until the LED is off, and then right after it turns on again, click **TAKE SCAN**. Then as soon as the voltage has reached its maximum, click **STOP SCAN** as soon as the LED turns off.

Name the scan in the **Scan Name** box with the type of tube (“Neon”) and any other information you deem relevant to knowing what it is. Then click **RETAIN SCAN** to save the scan in local memory. You will see the scan added to the **View scan** list.

Save the scan to disk with **SAVE TO FILE**. Use the extension **.wfm** (LabVIEW “waveform”) which is a special binary data format. It is a good idea to both “retain” and “save to file” each scan. In “retain” you can jump between different scans in local memory, but if the chart recorder closes, or crashes, the data in local memory will be lost. You can load old scans for inspection or analysis with **LOAD FROM FILE**.

The neon tube has the interesting feature that as the accelerating potential increases, bright and dark bands appear in the region between the two grids. You can observe these bands by using the cardboard tube placed directly over the little window in the black foil cover. Cup your hand around the top end of the tube and firmly against your forehead and cheek to block outside light. The orange bands should be clearly visible when the acceleration voltage is high. Try to correlate the changes in appearance of the bands with what you observe on the anode current trace. Note carefully where the glowing band first appears and how the pattern evolves as the accelerating voltage increases. **NOTE:** You may also be able to record a video of these bands, or a series of pictures by replacing your eye with your smart phone.

Look carefully at the anode current curve for neon. Note the small bumps or inflections that are visible near the troughs. These inflection are changes in the slope of the curve, and they can be “amplified” by the lock-in to appear as small peaks.

The origin of these small features comes from the fact of two closely-spaced sets of excitation

levels. For a subset of the electrons, there will be one (inelastic) collision at about 16.7 eV followed by a collision at 18.6 eV (or so) near the second minimum. At the third minimum, one will see other combinations: 2 collisions at 16.7 eV followed by another at 18.6 eV, or 1 collision at 16.7 followed by two at 18.6 eV. In general, the various combinations produce other periodicities in the anode current curve. Overall, the small features should be separated by about 1.7 eV, equal to the difference between the $3s$ states and the $3p$ states. You may use the lock-in peaks to check this.

2.2.3 Lock-In Amplifier Use

Once you have satisfactorily recorded (and retained/saved) the anode current, the next step is to use the lock-in detector to record the derivative of the anode current. The derivative curve will show the correlation between the zeroes of the derivative and the maxima and minima of the current, and it will also highlight changes in slope that occur when other energy states come into play.

Flip the “Plotter Y-axis” switch on the X-Y SWITCHBOX from “PDA-700” to “Lock-in”. Set the MODULATION VOLTAGE switch on the RAMP GENERATOR to ON.

Turn on the SR830 lock-in amplifier if it is not on yet (the power switch is on the back of the unit). Recommended settings for the SR830 are:

TIME CONSTANT: 100 mSec (“1”, “x100”, “ms” LEDs on)
Slope/Oct: 12 dB
Sync Filter: OFF
SIGNAL INPUT: A
Couple: DC coupled
Ground: GROUND
SENSITIVITY: 2 mV (“2”, “x1”, “mV nA”)
RESERVE: HIGH RESERVE
FILTERS: Line, 2X line, both on
CHANNEL 1: X
CHANNEL 1 OUTPUT: X
REFERENCE Source: INTERNAL
REFERENCE Phase: 0.00 degrees
REFERENCE Ampl: 0.040 V
REFERENCE Freq: 210 Hz
REFERENCE Harm #: 1

Select the 33 second ramp period and take a test scan. You should see a waveform that looks rather squarish, as the original waveform has a rounded-triangle type of shape with sharper corners at the top and bottom. (The derivative of a perfect triangle wave would be a perfect square wave. Think about this...) You should also see small bumps near the leading edge of each rising peak. These indicate sudden changes in the anode-current curve’s slope. You will measure differences between these smaller peaks to correlate with neon’s $3s$ – $3p$ state separation.

If all looks good, select the 250 second ramp period. Then change the TIME CONSTANT to 300 mSec, up from 100 mSec. Again, the ramp output will be at some arbitrary phase of the ramp cycle. Wait until the LED turns off and start a scan right when it turns on again. After recording the derivative curve, “retain” it and save it to a file.

You can confirm the “derivative” curve of the lock-in by using the measurement cursor on the chart recorder. Pull up the original anode current scan from the View scan list. Then use the “Measure” cursor to locate the precise value of a peak or a trough in the scan. To see the cursor, a red cross-hair, click the button CENTER CURSOR on the Chart Recorder’s lower chart border.

Drag the cursor to a peak or trough. Then from View scan, choose the curve created by the lock-in. The cursor will not move, but when you see it on the other data set, it should have its vertical axis touching the derivative scan very close to a zero-volt crossing. If you located a peak, the zero crossing should be “going down”—from positive slope to negative slope. If you located a trough, it should be the other way around.

To analyze the data, you will use this cursor capture feature to extract the X-axis locations of the peaks and troughs of the neon and mercury scans, the smaller bumps on the lock-in curve from neon, and the calibration points to convert X-axis measurements to acceleration voltage (see below).

Note: you can have a finer control over the cursor position by zooming in on a portion of the scan. Use the controls under the tab Crop Visible to first select a range of the scan to show with the blue vertical cursors that appear when you click SELECT X REGION. Move the two vertical lines with the mouse to surround what you want to zoom into, then click the button again. The positions will be saved. Then check the box next to Enable. You may need to recenter the red Measure cursor.

2.2.4 X-axis calibration

The Channel 2 measurements are proportional to the accelerating voltage between the cathode and grid, but the proportionality constant is only approximately 1/10. Before you analyze your data, you need to obtain a calibration of the X-axis measurement.

Here is one way to do it: First turn the filament current all the way down. This will kill the anode current signal. Set the RAMP GENERATOR to “Manual” control and dial the voltage all the way down to zero. Then start a scan, but use the manual control to increase the voltage. Adjust it upward by a few volts, and then reach for the “Plotter Y Axis” switch on the X-Y SWITCHBOX quick flip between the “PDA-700” and “Lock-in” setting. The scan trace should suddenly show a sharp vertical line associated with the different voltages coming in from the different inputs. Record the voltage displayed on the voltmeter at this point.

Then repeat the above steps: (1) Turn the voltage up a few volts (3–5 volts is fine), (2) flip the switch to mark that point on the trace, (3) record the voltmeter value. Do this until you have a collection of voltmeter readings and a trace with a series of vertical lines, with each line corresponding to each recorded value of the acceleration voltage.

Save the trace, and then use the cursor to locate the X position of each step, and include the recorded voltage for that step into the little spreadsheet window next to the cursor readings. Save this set of ordered points.

A second way to get the calibration data is to simply control the sweep voltage manually, and set it to a range of values between the minimum and the maximum. At each setting, record the voltmeter value and the value on the “Channel 2 Monitor” display at the lower left of the chart.

You can then fit the data to a line, and obtain the coefficients to convert a measured voltage on the Chart Recorder into a value of the acceleration voltage. These coefficients can then be used to rescale your data. In principle, the difference between the voltmeter values and recorded values should be a simple factor (close to 10), because the attenuator is just a resistor network. But offset errors in either device may create a small constant to include in the calibration.

2.2.5 Mercury set-up

Before collecting data from the mercury tube, make sure the filament current supply is turned all the way down and its output is switched off. (You may leave the little power supply on.) Then swap the filament leads for the ones attached to the mercury setup, again, red (positive) connects to the white binding post on the current supply, and black (negative) connects to the blue binding post.

Before turning up the filament current, make sure the thermometer is reading near 160 deg C. Then switch the current supply output on, and dial the current up to 300 mA. (Note: earlier versions of these instructions had the filament current set to 215 mA. The tube design has changed since.)

Repeat the procedure to collect data for the anode current versus accelerating voltage, and the derivative curve of the same from the lock-in amplifier, like you did for the neon tube. There are some differences, however:

- Set The PDA-700 amplifier to its most sensitive range, 20.00 nA full-scale.
- On the RAMP GENERATOR box set the RAMP SPAN to -40 volts; this will also select the output connected to the mercury apparatus.
- Change the X/Y Plotter input source to the Mercury Setup.

As earlier, take some test data using the 33 second ramp to make sure everything is working. The data set is much noisier because the anode current is much smaller than for the neon tube. You may want to play with the low-pass filtering to clean the fuzz of the data. Try the “Smoothing” filter on the plot adjustments section of the Chart recorder.

Note, you may see the overall curve drift in amplitude with repeated traces. This will happen when the apparatus is first used, and especially so if the temperature of the oven has not

reached a steady state. You will need to have a stable system to accurately compare the derivative curve to the anode current curve.

A copy of sample data is available in the lab to give you an idea of what the anode current curve (and derivative curve) looks like.

2.2.6 Shutdown

When you are done collecting data for the mercury tube, turn the filament current down to zero and shut off the filament supply, and turn the Variac down to zero and switch it off.

Turn off all the electronics, and make sure the Variac supplying the heater in the mercury tube housing is turn down to zero and switched off.

3 Data Analysis

You should have saved four data scans: anode current and derivative of anode current versus acceleration voltage for both the neon and mercury setups. The data analysis breaks roughly into two parts. The first part is to extract from the scans good images of the traces and the positions of features in each scan that you want to analyze further. The second part uses the extracted data to first calculate a calibration function, which is then applied to the measurements. Then the calibrated measurements should be plotted and fitted with lines and with quadratic curves, and from the results of these fits, estimates of the energy of the first excited states of neon and mercury are calculated. The calculation will be done according to a simple linear scheme, and then with the more sophisticated model of Rapior, Sengstock and Baev [3].

3.1 Data extraction and calibration

To make a good image of a trace, open the waveform file with the Chart Recorder application (or select it from the “retained scans” list, if it is still available). Then use the features under **Plot Controls and Adjustments** to manipulate the trace and prepare it for exporting or printing. Here are the options.

Filters

There are three types of data smoothing filters you may apply. Each only affects the displayed data, and may be added or removed at will.

LP Butterworth is a digital implementation of a “Butterworth” low-pass filter. It treats the data set as if it were a signal fed into an analog multi-stage LRC filter. The corner frequency of the filter is set by the “Time constant”. Longer time constants have a stronger effect, same as with the time constant setting on the lock-in amplifier. One side effect of using this filter is that it always forces the trace to start at zero (similar to the initial response of an uncharged RC filter). If your data starts near zero, this distortion may be minimal.

Smoothing Filter uses a simple data smoothing algorithm called “Savitzky-Golay.” Briefly, the method replaces each data point with a weighted average of that data point and a selection of neighboring data points. The more points you include (set by “Smoothing filter bins”) the more strongly the data set is smoothed out.

Median Filter is a nonlinear filter that is similar to the Smoothing filter in that it averages over neighboring data points, but in this form the data points are replaced by the *median* value rather than a weighted average. This type of filter tends to preserve sudden changes in the trace that are preserved by many points. One side effect is that as the number of “Median filter bins” is increased, the trace will take on a blocky appearance.

The proper amount of filtering does not noticeably affect the overall shape of the trace. Use filtering sparingly!

Number of points

This control allows you to replace the trace’s original data with a set of interpolated points. For slow scans, the data sets may get very large, with many more points than one needs. This may be annoying when you want to import a data set into another application, such as a spreadsheet or Python notebook.

You can see the effect of changing the number of points by selecting this option and observing the trace. The default number is 1000 points, but you may select any number, even more points than the data set contains.

To make a set for export, use this feature before selecting **Export Plot**.

Crop Visible

This control allows you to Zoom into a portion of the trace, or extract a portion for export. There are two steps to use this control:

SELECT X REGION Click this button and two vertical blue cursors will appear. Use the mouse to move them so that they surround the region of interest you wish. Then click the button again to extract the cursor locations. These will show up in the **Low** and **High** displays.

Enable The checkbox does the work. When selected the data will be cropped to the selected range. Deselecting the checkbox brings the original range back into view.

One use for this feature is to get a better resolution on the positioning of the Measure cursor. When you Zoom into the data, the smallest division recorded by the cursor decreases.

Export Plot

This is the output control for data sets to be plotted or to create a file usable by other applications.

EXPORT PLOT DATA builds a spreadsheet file (of type “CSV”, or “comma-separated values”) with columns for each of x-values and y-values. The values exported are subject to the results of the three previous adjustments (filtering, point interpolation, and cropping).

You get the traces you see on the screen as a data file.

PRINT PLOT Opens a dialog box that shows only the plot window and a text box. You may add notes to the text box to describe what you see. Then you can send the results to the default web browser for the computer. From the browser you may cut and paste into your notebook, or print to PDF, or whatever you like.

In your notebook, show the anode current traces near or even on the same plot as the anode-current derivative traces, so they can be compared easily by eye. If you plot the curves on the same graph You will need to scale the data sets vertically, because the voltage output of the lock-in amp is much higher than the anode-current voltages produced by the PDA-700 amplifiers.

You should also have images or sketches of the glow-pattern of the neon tube, annotated photos of the setup, and images/sketches of the individual Franck-Hertz tubes that contain dimensions and measurements of the electrode spacing.

After obtaining images of the possibly cleaned-up data traces, use the Measurement Cursor to extract the locations of the following features from the data and create spreadsheets for each:

1. The x-axis calibration marks versus the corresponding voltmeter readings, as obtained in section 2.2.4.
2. The locations of the peaks and troughs in the anode-current traces for neon and mercury setups. These will be used to estimate the lowest excited state energy for each element.
3. The locations of the small peaks and troughs from the lock-in (derivative) scan taken from the neon setup. These will be used to estimate the energy separation between the $3s$ and $3p$ levels of neon.

Use of the Measurement Cursor is straightforward. Click the **CENTER CURSOR** button at the lower right of the Chart Recorder to bring the red cross-hairs into the center of the plot screen. Drag the cursor to the location of the feature you want to record.

Click **CAPTURE CURSOR** in the box at the lower left of the Chart Recorder. The coordinates of the cursor will appear in the little spreadsheet.

After the cursor is captured, you may edit/modify the **Scan Name/Label** cell, for example, to record the voltmeter value corresponding to a particular calibration point. (Note: do not edit this cell until the coordinates have been captured. See what happens if you violate this rule!)

After you have collected the points you need, click **EXPORT TABLE** to export the table to Microsoft Excel. Unless Excel has already been started, this may take a minute—have patience. Excel will open, and from here, you may edit the file and then save it.

When you collect the small-peak locations from the neon lock-in trace, you should save the measurements in pairs, with the lower value in the left column and upper value in the right

column. For example, if you have three closely-spaced small peaks located at 2.172, 2.352 and 2.492 volts (with the original, uncalibrated channel 2 as the x-axis), these would correspond to the pairs (2.172, 2.352) and (2.352, 2.492) whose difference should be proportional to the $3p$ - $3s$ states energy separation. So the lower values of each pair should go in one column, and the higher values should go in another. Then it is simple to take differences by using a spreadsheet formula, or a Python NumPy operation on the arrays representing each column.

3.2 Calculations

Once you have these data sets, you may follow the instructions in the Jupyter notebook template to analyze them further, as described below.

Data Reduction

- Print tables showing the spreadsheets created above to include in your notebook.
- Create a calibration plot and make a line fit for the x-axis voltage calibration. From the fit coefficients, create a calibration function to convert measured voltage into actually-applied voltage.
- Use the calibration function to calculate voltage values for all features to be analyzed in Hg and Ne scans.

Data Analysis

- Assign numbers to each extracted feature (either “troughs” or “peaks”) in the two sets of anode-current measurements. For example, assign the first visible peak to 1, the second to 2, and so forth. Likewise assign the first visible trough after the first peak to 1, the second trough to 2, etc.
- Create plots of feature voltages (peaks and troughs) versus feature number for each tube.
- Fit these points to both a line (“traditional method”) and a quadratic (to be used in “RSB method”).
- For Neon:
 - For the traditional method: Calculate estimates of the average voltage separation from line fits, and thus find the first excited state of Ne along with its uncertainty.
 - For the method of RSB, use the quadratic fit results and the theory described in their paper and the posted lecture notes to find the first excited state E_a of Ne.

- Then take differences of between each successive point to obtain $E(n)$ according to the definition of RSB. Plot these points, and fit them to a line. From these fit results derive a second set of values for the first excited state E_a . Obtain an uncertainty from the fit results.
- Carry out a similar analysis for the mercury tube data.
- Include tables of the results for E_a for each of Ne and Hg as found from the different methods.
- Also for neon: Determine the average separation of small features recorded on lock-in trace. How do these compare to $3s$ - $3p$ state spacing? Describe your observation of the Ne-tube’s glowing bands and discussion of relationship to the Ne anode current vs. acceleration voltage curve.
- Calculate the mean-free-path from RSB method to compare it to the estimate from Exercise 2 in section 1.1.

References

- [1] McMahon, D. R. A., “Elastic electron-atom collision effects in the Franck-Hertz experiment,” *Am. J. Phys.* **51**, 1086 (1983).
- [2] Sigenege, F., R. Winkler, and R. E. Robson, “What really happens with the electron gas in the famous Franck-Hertz experiment?” *Contrib. Plasma Phys.*, **43**, 178–197 (2003).
- [3] Rapior, G., K. Sengstock, and V. Baev, “New features of the Franck-Hertz experiment,” *Am. J. Phys.*, **74**, 423–428 (2006).
- [4] John Emsley, *The Elements*, Oxford University Press (1989).
- [5] Paul Horowitz and Winfield Hill, *The Art of Electronics*, 2d ed., pp. 1030-1034 (1989).

Prepared by J. Stoltenberg, D. B. Pengra, and J. A. Detwiler
 franck-hertz_2024.tex -- Updated 26 June 2024.