

# Estuaries -- Phytoplankton Protocol

Revised 4/19/2012 by Nannette Huber

## Fixing Plankton Samples

### Supplies Needed:

Phytoplankton samples  
37% Formaldehyde  
Transfer pipette  
Hood Space  
Gloves

Safety glasses  
Lab coat  
Absorbent pad (a versi-dry pad or a few  
paper towels will work)

You are working with formaldehyde. Make sure you read the MSDS and EHS Protocol for its use.

- 1) Wear gloves, glasses & labcoat. Work in one of the formaldehyde hoods (the L&O lab has one as does SCI 215).
- 2) Working one jar at a time, open the sample jar and use a transfer pipette to add approximately 1mL of 37% formaldehyde in the sample jar. Do not put the pipette directly into the sample, rather hold the pipette tip above the surface of the sample and dispense the formaldehyde gently without making too many airborne particles.
  - a. Samples that are dense with plankton (like Spring net samples) might need more than 1 mL of formaldehyde. If you are unsure if you should add more, ask.
- 3) Once the sample has been fixed with formaldehyde, replace the jar lid. Make sure the sample jar lid is firmly in placed and gently shake the jar to distribute the formaldehyde throughout the sample.
- 4) Repeat for all your samples.
- 5) When completely finished, make sure the 37% formalin container is sealed and is back in the formaldehyde hood.
- 6) Samples should be in a box labeled with the sampling date and location and stored in the formaldehyde hood.
- 7) Wash your hands.

# Estuaries -- Phytoplankton Protocol

Revised 4/19/2012 by Nannette Huber

## Decanting “Bottle” Plankton Samples

\*Only “bottle” samples (surface and thermocline samples) need to be decanted prior to counting. Net samples can be assessed without decanting.

\*Plankton samples should only be decanted after they have been allowed to settle for a minimum of 24 hours.

### Materials Needed

Plankton sample(s)	Lab coat
“Formalin” Pipette	Decant log sheet & Pen
Pipette tips	Hand-held clicker/counter
“Formalin” Graduated cylinder	
“Formalin” Waste beaker	If needed for Step 1:
Formaldehyde (waste) carboy	Clean plankton jar
Safety gloves	Sharpie
Lab glasses/goggles	

\*It is very important that you decant plankton one jar at a time to avoid possible mix-up and/or contamination of samples.

\*All work should be done in the hood while wearing proper safety attire.

1. Make sure the plankton jar has a visible 10mL line drawn near its base. If there is a line, proceed to step 3. If not, follow the direction below:
  - a. If this line is missing on the sample jar, find a new, clean plankton jar. If the new jar has a 10 mL mark near the base, proceed to step 2. If not, follow directions below:
    - i. Use a pipette to measure 10mL of water into the jar
    - ii. Use a black sharpie or other permanent marker to mark the meniscus of the waterline on the new jar. Be sure to mark from eye level – don’t look down at the water or up at the water when you mark it.
    - iii. Once the line is drawn, dump the water and allow the jar to dry thoroughly before moving onto step 2.
2. Once you have a clean, dry jar with a 10mL line on it:
  - a. Give the old jar a little swirl to move the plankton away from the sides of the jar and concentrate towards the center.
  - b. Carefully remove the old lid and pour the plankton into the new jar with the 10mL line.
  - c. Put the old lid (with the sampling data label) onto the new jar.
  - d. Set the new plankton jar aside to settle for at least 24 hours before moving onto step 3.
  - e. The old plankton jar should be triple rinsed into the formaldehyde waste carboy then washed as usual in the sink.

# Estuaries -- Phytoplankton Protocol

Revised 4/19/2012 by Nannette Huber

3. After the sample has settled for at least 24 hours, decant the excess water above the 10 mL line.
  - a. Use the pipette specifically marked "FORMALIN" to avoid the spread of formalin contamination. Always use a fresh pipette tip for each sample.
    - i. You can use the pipette set to 5mL while you decant 50-75mL of the water.
    - ii. Once you decant 50-75mL, set the pipette to 1mL and remove the rest of the water. You will know you have decanted the right amount when the meniscus of the waterline lines up with the black line on the jar. Be sure you are looking at the meniscus from eye level – don't look down at the line or up at the line.
  - b. Decant the water into a waste beaker, not directly into the waste carboy.
  - c. As you decant, keep track of how much water you have decanted with a hand-held counter. Should you loose count (it happens!) you can pour from the waste beaker into a graduated cylinder to measure the amount decanted.
  - d. Once you have decanted all the water above the 10mL line, record how much water you have decanted on a log sheet.
  - e. Once you have recorded the decant amount, you can discard the liquid in the waste beaker by putting it into the larger waste container.
  - f. Put the lid back on the plankton jar and set aside for counting.
  - g. Repeat from step 1 if you have another jar to decant.
  
4. When you are finished all your decanting, clean your workspace. To clean the waste beaker and graduated cylinder used for decanting formaldehyde, triple rinse with DI Water and pour the wastewater into the formaldehyde waste carboy. Then the items can be washed as usual in the sink. Used pipette tips should be disposed of in the broken glass box. Gloves can go into the trash.

## Loading a Sedgewick-Rafter Counting Chamber

### Supplies needed:

Plankton sample(s)  
Paper Towel or Kim Wipe  
Safety gloves  
Pipette & tips  
Sedgewick-Rafter Counting Chamber and Cover slip

Always follow safety protocols -- particularly if the samples have been fixed with formalin prior to counting.

Before preparing the slides for counting, make sure surface or thermocline samples have been decanted. Net samples can be assessed without decanting.

# Estuaries -- Phytoplankton Protocol

Revised 4/19/2012 by Nannette Huber

1. Remove the sample container from the fume hood and swirl to mix the sample.
2. Place counting chamber on a clean paper towel or kim wipe to avoid scratching the bottom surface.
3. Using a pipette and clean tip, dispense 1 mL of the sample onto the Sedgewick-Rafter counting chamber (see image).
4. Slide a cover slip in place, assuring no air bubbles are trapped in the slide. If there are air bubbles, they can often be removed if you lightly maneuver the cover glass from side-to-side. If this does not work, you may need to reload the slide with a new sample.
5. Once the slide is filled, let settle for approximately 5-10 minutes to allow the plankton to settle into a single layer. This makes counting easier. Use this settling time to calibrate the scale on the ocular micrometer.

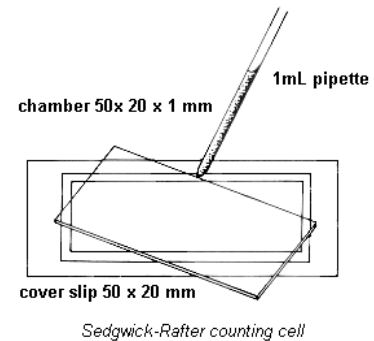

## Measurement with the Light Microscope

(taken from Measurement and Counting with the Light Microscope Rice.doc)

Your microscope may be equipped with a scale (called a reticule) that is built into one eyepiece. The reticule can be used to measure any planar dimension in a microscope field since the ocular can be turned in any direction and the object of interest can be repositioned with the stage manipulators. To measure the length of an object note the number of ocular divisions spanned by the object. Then multiply by the conversion factor for the magnification used. The conversion factor is different at each magnification. Therefore, when using a reticule for the first time, it is necessary to calibrate the scale by focusing on a second micrometer scale (a stage micrometer) placed directly on the stage.

## Conversion factor

Identify the ocular micrometer. A typical scale consists of 50 - 100 divisions. You may have to adjust the focus of your eyepiece in order to make the scale as sharp as possible. If you do that, also adjust the other eyepiece to match the focus. Any ocular scale must be calibrated, using a device called a stage micrometer. A stage micrometer is simply a microscope slide with a scale etched on the surface. A typical micrometer scale is 2 mm long and at least part of it should be etched with divisions of 0.01 mm (10  $\mu\text{m}$ ).

# Estuaries -- Phytoplankton Protocol

Revised 4/19/2012 by Nannette Huber

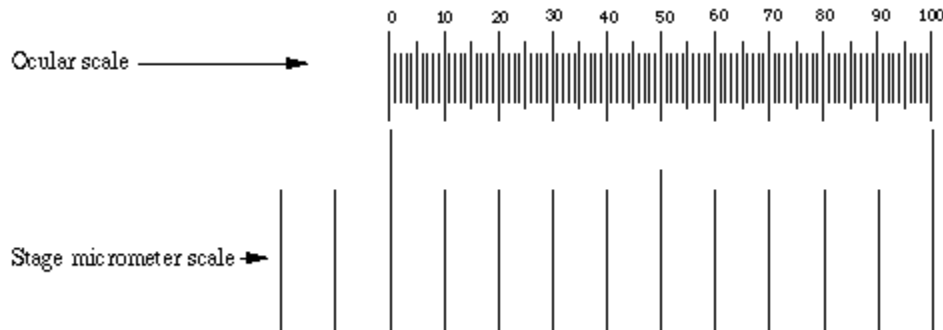

Suppose that a stage micrometer scale has divisions that are equal to 0.1 mm, which is 100 micrometers ( $\mu\text{m}$ ). Suppose that the scale is lined up with the ocular scale, and at 100x it is observed that each micrometer division covers the same distance as 10 ocular divisions. Then one ocular division (smallest increment on the scale) = 10  $\mu\text{m}$  at 100 power. The conversion to other magnifications is accomplished by factoring in the difference in magnification. In the example, the calibration would be 25  $\mu\text{m}$  at 40x, 2.5  $\mu\text{m}$  at 400x, and 1  $\mu\text{m}$  at 1000x.

Some stage micrometers are finely divided only at one end. These are particularly useful for determining the diameter of a microscope field. One of the larger divisions is positioned at one edge of the field of view, so that the fine part of the scale overlaps the opposite side. The field diameter can then be determined to the maximum available precision.

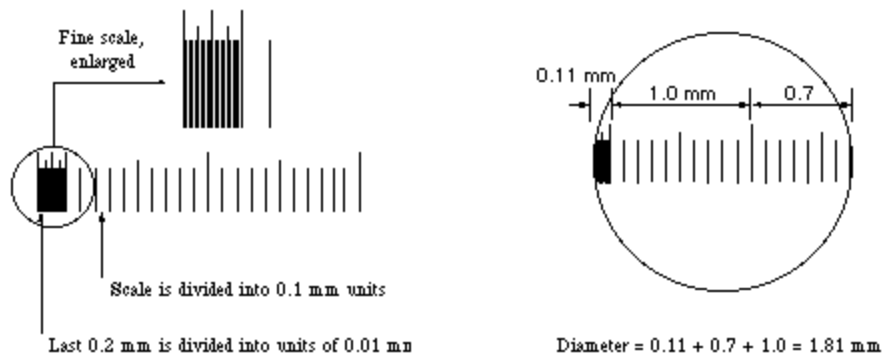

Use the micrometer to determine the ocular scale for the microscope. Once you know this, you can use it to determine the size of unknown plankton and to determine the length and width of the Sedgewick-Rafter transect you count.

Example:

The scale of the reticule is 4 tickmarks to .1 mm on the stage micrometer

An unknown plankton is 13 tickmarks wide.

$$13 \text{ tickmarks} \times \frac{0.1 \text{ mm}}{4 \text{ tickmarks}} = 0.325 \text{ mm}$$

# Estuaries -- Phytoplankton Protocol

Revised 4/19/2012 by Nannette Huber

The plankton is 0.325 mm wide.

Sedgewick-Rafters are 50mm x 20 mm x 1 mm. You will count the full 50mm length. Use the stage micrometer to determine how wide the transect is. You will need these numbers to determine the volume of the sample counted.

## Counting Bottle Samples and Assessing Net Samples

### Supplies Needed:

Prepared slide

Microscope

Lens Paper (for cleaning dirty microscope parts)

Kim-Wipe

Plankton identification books

1. Begin by turning on the microscope.
2. Set the microscope to its lowest focus and bring the sample into focus. Be sure you are focusing on the sample in the side and not on top of the coverslip.
3. Change the focus to the next strongest magnification and bring the sample into focus. Repeat until you are using the best magnification possible. For the research scope, this will be the 20x lens. For the general lab microscopes, 20x is not available so choose an available lens strength close to 20x magnification. Use the magnification that allows you to best identify the plankton you see.
4. You will count only one transect of the Sedgewick-Rafter. Choose a random transect near the top or bottom of the slide. Methodically move through the slide identifying each cell you encounter. To avoid counting a single plankton more than once, **do not count phytoplankton that cross the bottom of the field of view.**
  - a. Assessing Net Samples
    - i. When assessing a net samples, identify and record each genus of plankton you find.
    - ii. After looking across an entire transect, decide the presence of each genus and assign a qualitative value of:
      1. Blooming
      2. Abundant
      3. Common
      4. Rare
  - b. Counting Surface or Thermocline Samples
    - i. Identify and and count each cell you encounter and record it on your log sheet.
      1. Use plankton identification books to help you identify the cells you find.
      2. Count each and every cell unless they are partial cells along the bottom of your transect. You will count these partial cells during the next transect.
        - a. A tally works best when only a few cells are in each transect.

# Estuaries -- Phytoplankton Protocol

Revised 4/19/2012 by Nannette Huber

- b. For large numbers of cells, use a counter.
  - ii. If a cell can't be identified, draw a picture (with scale). Name the plankton so that it can be referred to by that name in future counts.
  - iii. Continue counting full transects until you have a minimum of 100 plankton counted. Record the number of transects counted on the log sheet.
5. When finished assessing or counting the slide, the slide and coverslip can be washed (triple rinse with DI into the formaldehyde waste carboy) and dried with a kimwipe and used for the next sample. Discard the used pipette tip in the broken glass box. Gloves, when you are done, can go in the trash.
6. Once a sample has been counted, the sample jar should be put back in the hood until it can be archived. Never waste or otherwise discard a sample!
7. Turn off microscope and prepare it for the next user.
  - a. Set the magnification to the lowest power.
  - b. Turn the light to the dimmest setting.
  - c. Lower the stage to the lowest point.
  - d. Wipe any water or other debris from the stage or other areas of the scope.
  - e. Unplug and wrap the cord around the base of the microscope.
  - f. Replace the dust cover and return the microscope to its proper location.
8. Enter the information from the logsheet(s) you created into an excel file (see Calculating Concentration below)

## Calculating Concentration

1. Using the sample log sheet, create an excel spreadsheet and organize your data by station or Month sampled
2. Create a column for species or genus name, cells counted, Initial volume (volume of the slide), initial concentration (cells ÷ volume of slide), Volume Factor (concentrated amount + amount decanted), Concentration Factor (which volume factor/concentrated amount), and final concentration in cells/liter. Here's the calculation:

$$(\text{cells counted} \div \text{slide volume}) \times \frac{1}{\text{Concentration Factor}} \times \frac{1000\text{mL}}{L} = \# \text{ cells/L}$$

Ex: A sample had 120mL decanted, making the total volume 130mL (120+10mL). The concentration factor would be  $130\text{mL} \div 10\text{ mL}$  , which is 13. You counted 15 of *species A* in the palmer counting cell, which holds .1mL. The calculation would be:

$$(15 \div .1\text{mL}) \times \frac{1}{13} \times \frac{1000\text{mL}}{L} = 11538 \text{ cells/L}$$